

Very low drop voltage regulators with inhibit

Features

- Very low dropout voltage (0.4 V)
- Very low quiescent current
- (Typ. 50 μ A in off mode, 600 μ A in on mode)
- Output current up to 250 mA
- Logic-controlled electronic shutdown
- Output voltages of 1.5; 2.5; 2.7; 3.3; 3.5; 4.7; 5; 8; 12 V
- Automotive Grade product: 2.7 V, 3.3 V, 3.5 V V_{OUT} only in SO-8 package
- Internal current and thermal limit
- Only 2.2 μ F for stability
- Available in $\pm 1\%$ (AB) or 2% (C) selection at 25 °C
- Supply voltage rejection: 70 dB typ. for 5 V version
- Temperature range: -40 to 125 °C

Description

The L4931ABxx L4931Cxx are very Low Drop regulators available in TO-220, SO-8, DPAK, PPAK and TO-92 packages and in a wide range of output voltages.

The very low drop voltage (0.4 V) and the very low quiescent current make them particularly suitable for low noise, low power applications and specially in battery powered systems.

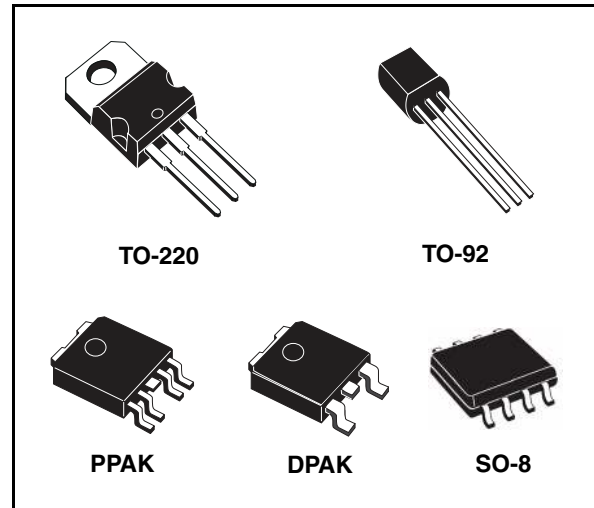

A TTL compatible shutdown logic control function is available in PPAK and SO-8 packages. This means that when the device is used as a local regulator, it is possible to put a part of the board in standby, decreasing the total power consumption. It requires only a 2.2 μ F capacitor for stability allowing space and cost saving.

The L4931 is available as Automotive Grade in SO-8 package only, for the options of output voltages whose commercial Part Numbers are shown in the [Table 24](#) (order codes). These devices are qualified according to the specification AEC-Q100 of the Automotive market, in the temperature range -40 °C to 125 °C, and the statistical tests PAT, SYL, SBL are performed.

Table 1. Device summary

Part number			
L4931ABXX15	L4931CXX27	L4931CXX47	L4931ABXX120
L4931CXX15	L4931ABXX33	L4931ABXX50	L4931ABXX120
L4931ABXX25	L4931CXX33	L4931CXX50	
L4931CXX25	L4931ABXX35	L4931ABXX80	
L4931ABXX27	L4931CXX35	L4931CXX80	

Contents

1	Diagram	3
2	Pin configuration	4
3	Maximum ratings	5
4	Application circuits	6
5	Electrical characteristics	7
6	Typical application	27
7	Package mechanical data	28
8	Order codes	37
9	Revision history	38

List of figures

Figure 1.	Schematic diagram	4
Figure 2.	Pin connections (top view)	5
Figure 3.	Test circuits.	7
Figure 4.	Line regulation vs temperature	28
Figure 5.	Dropout voltage vs temperature	28
Figure 6.	Supply current vs input voltage.	28
Figure 7.	Supply current vs temperature	28
Figure 8.	Short circuit current vs dropout voltage	29
Figure 9.	S.V.R. vs Input voltage signal frequency	29

List of tables

Table 1.	Device summary	1
Table 2.	Absolute maximum ratings	7
Table 3.	Thermal data	7
Table 4.	Electrical characteristics of L4931ABxx15	9
Table 5.	Electrical characteristics of L4931Cxx15	10
Table 6.	Electrical characteristics of L4931ABxx25	11
Table 7.	Electrical characteristics of L4931Cxx25	12
Table 8.	Electrical characteristics of L4931ABxx27	13
Table 9.	Electrical characteristics of L4931Cxx27	14
Table 10.	Electrical characteristics of L4931Cxx27-TRY (Automotive Grade)	15
Table 11.	Electrical characteristics of L4931ABxx33	16
Table 12.	Electrical characteristics of L4931Cxx33	17
Table 13.	Electrical characteristics of L4931Cxx33-TRY (Automotive Grade)	18
Table 14.	Electrical characteristics of L4931ABxx35	19
Table 15.	Electrical characteristics of L4931ABxx35-TRY (Automotive Grade)	20
Table 16.	Electrical characteristics of L4931Cxx35	21
Table 17.	Electrical characteristics of L4931Cxx47	22
Table 18.	Electrical characteristics of L4931ABxx50	23
Table 19.	Electrical characteristics of L4931Cxx50	24
Table 20.	Electrical characteristics of L4931ABxx80	25
Table 21.	Electrical characteristics of L4931Cxx80	26
Table 22.	Electrical characteristics of L4931ABxx120	27
Table 23.	Electrical characteristics of L4931Cxx120	28
Table 24.	Order codes	39
Table 25.	Document revision history	40

1 Diagram

Figure 1. Schematic diagram

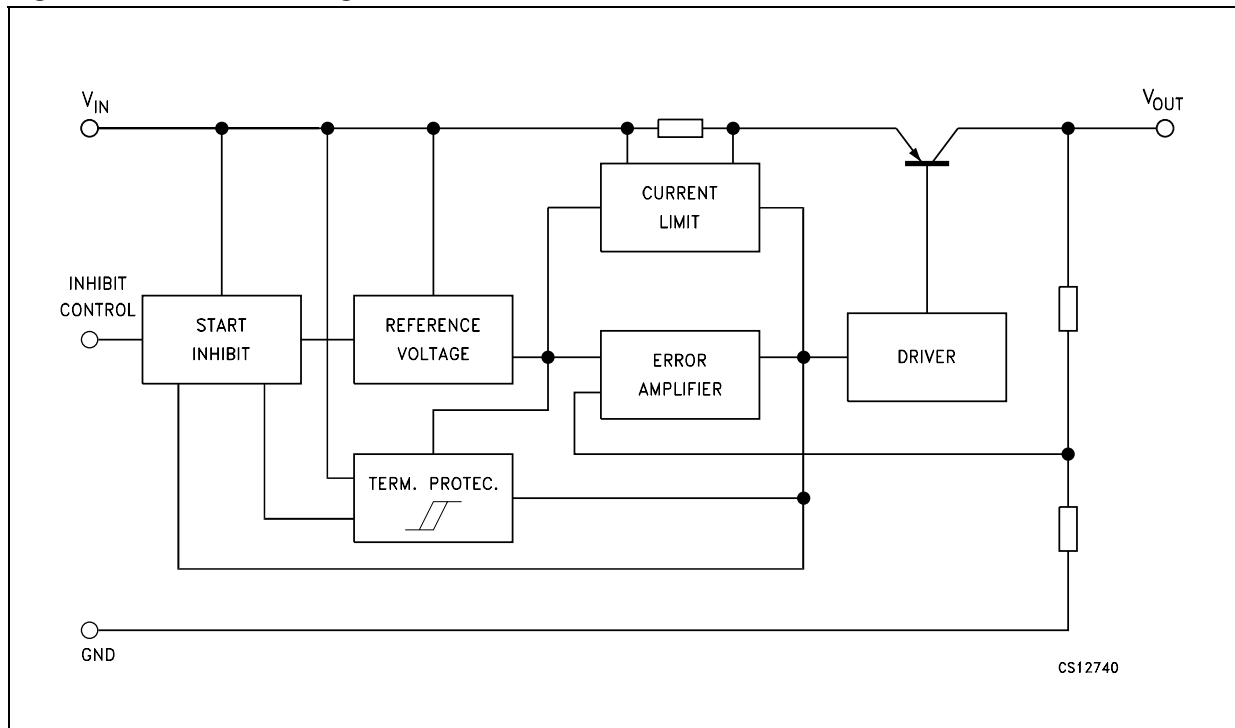

2 Pin configuration

Figure 2. Pin connections (top view)

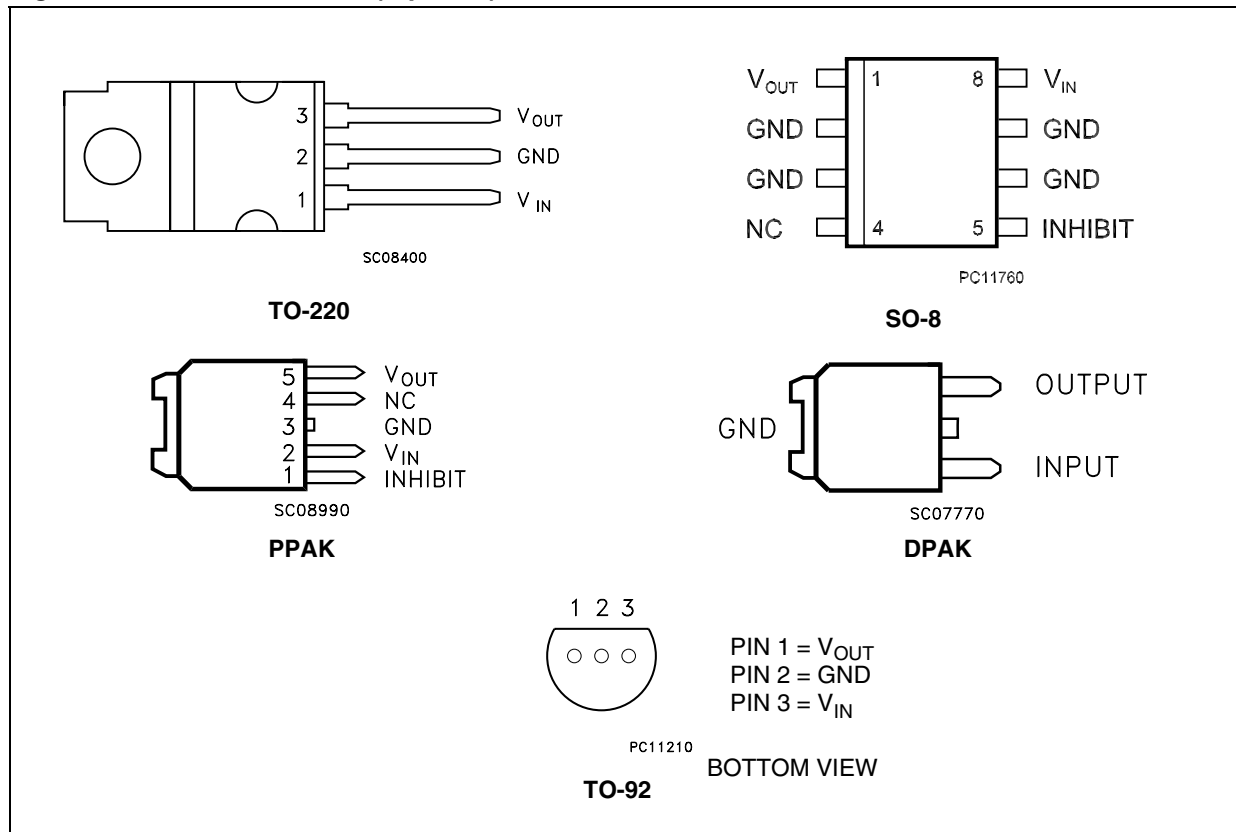

3 Maximum ratings

Table 2. Absolute maximum ratings

Symbol	Parameter	Value	Unit
V_I	DC Input voltage	20	V
I_O	Output current	Internally limited	mA
P_D	Power dissipation	Internally limited	mW
T_{STG}	Storage temperature range	-40 to 150	°C
T_{OP}	Operating junction temperature range	-40 to 125	°C

Note: Absolute maximum ratings are those values beyond which damage to the device may occur. Functional operation under these condition is not implied

Table 3. Thermal data

Symbol	Parameter	TO-220	SO-8	DPAK	PPAK	TO-92	Unit
R_{thJC}	Thermal resistance junction-case	3	20	8	8		°C/W
R_{thJA}	Thermal resistance junction-ambient	50	55	100	100	200	°C/W

4 Application circuits

Figure 3. Test circuits

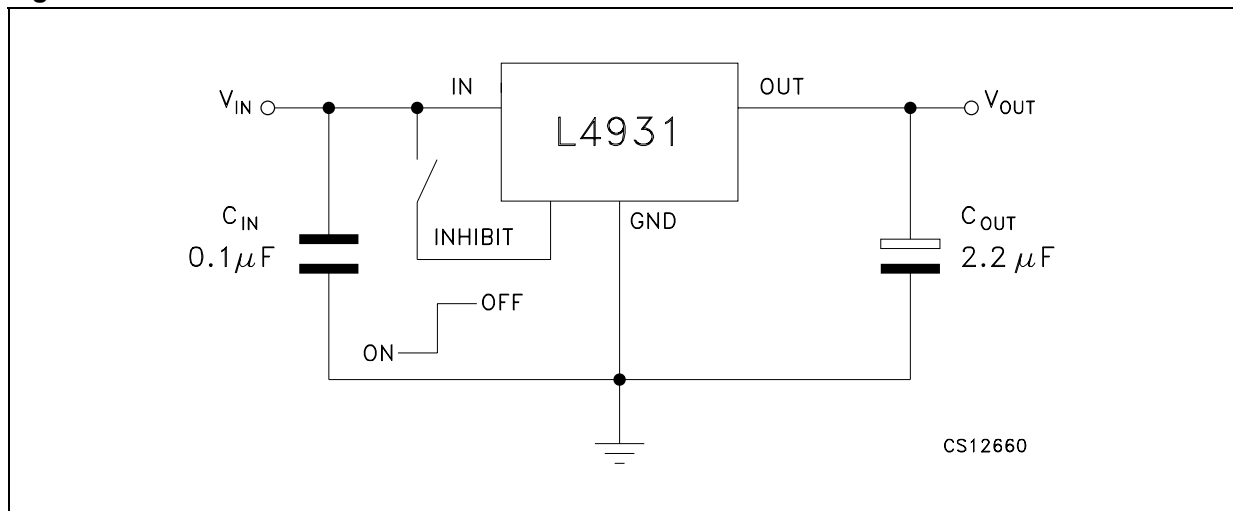

5 Electrical characteristics

Table 4. Electrical characteristics of L4931ABxx15 (refer to the test circuits, $T_A = 25\text{ }^\circ\text{C}$, $C_I = 0.1\text{ }\mu\text{F}$, $C_O = 2.2\text{ }\mu\text{F}$ unless otherwise specified).

Symbol	Parameter	Test conditions	Min.	Typ.	Max.	Unit
V_O	Output voltage	$I_O = 5\text{ mA}$, $V_I = 3.5\text{ V}$	1.485	1.5	1.515	V
		$I_O = 5\text{ mA}$, $V_I = 3.5\text{ V}$, $T_A = -25\text{ to }85\text{ }^\circ\text{C}$	1.47		1.53	
V_I	Operating input voltage	$I_O = 250\text{ mA}$	2.5		20	V
I_{out}	Output current limit			300		mA
ΔV_O	Line regulation	$V_I = 2.5\text{ to }20\text{ V}$, $I_O = 0.5\text{ mA}$		3	15	mV
ΔV_O	Load regulation ⁽¹⁾	$V_I = 2.7\text{ V}$, $I_O = 0.5\text{ to }250\text{ mA}$		3	15	mV
I_d	Quiescent current ON MODE	$V_I = 2.7\text{ to }20\text{ V}$, $I_O = 0\text{ mA}$		0.6	1	mA
		$V_I = 2.7\text{ to }20\text{ V}$, $I_O = 250\text{ mA}$		4	6	
	OFF MODE	$V_I = 6\text{ V}$		50	100	μA
SVR	Supply voltage rejection	$I_O = 5\text{ mA}$ $V_I = 3.7 \pm 1\text{ V}$	$f = 120\text{ Hz}$		79	dB
			$f = 1\text{ KHz}$		76	
			$f = 10\text{ KHz}$		55	
eN	Output noise voltage	$B = 10\text{ Hz to }100\text{ KHz}$		50		μV
V_d	Dropout voltage ⁽¹⁾	$I_O = 250\text{ mA}$		1		V
V_{IL}	Control input logic low	$T_A = -40\text{ to }125\text{ }^\circ\text{C}$			0.8	V
V_{IH}	Control Input Logic High	$T_A = -40\text{ to }125\text{ }^\circ\text{C}$	2			V
I_I	Control input current	$V_I = 6\text{ V}$, $V_C = 6\text{ V}$		10		μA
C_O	Output bypass capacitance	$\text{ESR} = 0.1\text{ to }10\text{ }\Omega$, $I_O = 0\text{ to }250\text{ mA}$	2	10		μF

1. For SO-8 package the maximum limit of load regulation and dropout is increased by 20 mV.

Table 5. Electrical characteristics of L4931Cxx15 (refer to the test circuits, $T_A = 25\text{ }^\circ\text{C}$, $C_I = 0.1\text{ }\mu\text{F}$, $C_O = 2.2\text{ }\mu\text{F}$ unless otherwise specified).

Symbol	Parameter	Test conditions	Min.	Typ.	Max.	Unit
V_O	Output voltage	$I_O = 5\text{ mA}$, $V_I = 3.5\text{ V}$	1.47	1.5	1.53	V
		$I_O = 5\text{ mA}$, $V_I = 3.5\text{ V}$, $T_A = -25\text{ to }85\text{ }^\circ\text{C}$	1.44		1.56	
V_I	Operating input voltage	$I_O = 250\text{ mA}$	2.5		20	V
I_{out}	Output current limit			300		mA
ΔV_O	Line regulation	$V_I = 2.5\text{ to }20\text{ V}$, $I_O = 0.5\text{ mA}$		3	18	mV
ΔV_O	Load regulation ⁽¹⁾	$V_I = 2.7\text{ V}$, $I_O = 0.5\text{ to }250\text{ mA}$		3	18	mV
I_d	Quiescent current ON MODE	$V_I = 2.7\text{ to }20\text{ V}$, $I_O = 0\text{ mA}$		0.6	1	mA
		$V_I = 2.7\text{ to }20\text{ V}$, $I_O = 250\text{ mA}$		4	6	
	OFF MODE	$V_I = 6\text{ V}$		50	100	μA
SVR	Supply voltage rejection	$I_O = 5\text{ mA}$ $V_I = 3.7 \pm 1\text{ V}$	$f = 120\text{ Hz}$		79	dB
			$f = 1\text{ KHz}$		76	
			$f = 10\text{ KHz}$		55	
eN	Output noise voltage	$B = 10\text{ Hz to }100\text{ KHz}$		50		μV
V_d	Dropout voltage ⁽¹⁾	$I_O = 250\text{ mA}$		1		V
V_{IL}	Control input logic low	$T_A = -40\text{ to }125\text{ }^\circ\text{C}$			0.8	V
V_{IH}	Control Input Logic High	$T_A = -40\text{ to }125\text{ }^\circ\text{C}$	2			V
I_I	Control input current	$V_I = 6\text{ V}$, $V_C = 6\text{ V}$		10		μA
C_O	Output bypass capacitance	$\text{ESR} = 0.1\text{ to }10\text{ }\Omega$, $I_O = 0\text{ to }250\text{ mA}$	2	10		μF

1. For SO-8 package the maximum limit of load regulation and dropout is increased by 20 mV.

Table 6. Electrical characteristics of L4931ABxx25 (refer to the test circuits, $T_A = 25\text{ }^\circ\text{C}$, $C_I = 0.1\text{ }\mu\text{F}$, $C_O = 2.2\text{ }\mu\text{F}$ unless otherwise specified).

Symbol	Parameter	Test conditions	Min.	Typ.	Max.	Unit
V_O	Output voltage	$I_O = 5\text{ mA}$, $V_I = 4.5\text{ V}$	2.475	2.5	2.525	V
		$I_O = 5\text{ mA}$, $V_I = 4.5\text{ V}$, $T_A = -25\text{ to }85\text{ }^\circ\text{C}$	2.45		2.55	
V_I	Operating input voltage	$I_O = 250\text{ mA}$			20	V
I_{out}	Output current limit			300		mA
ΔV_O	Line regulation	$V_I = 3.2\text{ to }20\text{ V}$, $I_O = 0.5\text{ mA}$		3	15	mV
ΔV_O	Load regulation ⁽¹⁾	$V_I = 3.4\text{ V}$, $I_O = 0.5\text{ to }250\text{ mA}$		3	15	mV
I_d	Quiescent current ON MODE	$V_I = 3.4\text{ to }20\text{ V}$, $I_O = 0\text{ mA}$		0.6	1	mA
		$V_I = 3.4\text{ to }20\text{ V}$, $I_O = 250\text{ mA}$		4	6	
	OFF MODE	$V_I = 6\text{ V}$		50	100	μA
SVR	Supply voltage rejection	$I_O = 5\text{ mA}$ $V_I = 4.4 \pm 1\text{ V}$	$f = 120\text{ Hz}$		75	dB
			$f = 1\text{ KHz}$		72	
			$f = 10\text{ KHz}$		55	
eN	Output noise voltage	$B = 10\text{ Hz to }100\text{ KHz}$		50		μV
V_d	Dropout voltage ⁽¹⁾	$I_O = 250\text{ mA}$		0.4	0.6	V
		$I_O = 250\text{ mA}$, $T_A = -40\text{ to }125\text{ }^\circ\text{C}$			0.8	V
V_{IL}	Control input logic low	$T_A = -40\text{ to }125\text{ }^\circ\text{C}$			0.8	V
V_{IH}	Control Input Logic High	$T_A = -40\text{ to }125\text{ }^\circ\text{C}$	2			V
I_I	Control input current	$V_I = 6\text{ V}$, $V_C = 6\text{ V}$		10		μA
C_O	Output bypass capacitance	$\text{ESR} = 0.1\text{ to }10\text{ }\Omega$, $I_O = 0\text{ to }250\text{ mA}$	2	10		μF

1. For SO-8 package the maximum limit of load regulation and dropout is increased by 20 mV.

Table 7. Electrical characteristics of L4931Cxx25 (refer to the test circuits, $T_A = 25\text{ }^\circ\text{C}$, $C_I = 0.1\text{ }\mu\text{F}$, $C_O = 2.2\text{ }\mu\text{F}$ unless otherwise specified).

Symbol	Parameter	Test conditions	Min.	Typ.	Max.	Unit
V_O	Output voltage	$I_O = 5\text{ mA}$, $V_I = 4.5\text{ V}$	2.45	2.5	2.55	V
		$I_O = 5\text{ mA}$, $V_I = 4.5\text{ V}$, $T_A = -25\text{ to }85\text{ }^\circ\text{C}$	2.4		2.6	
V_I	Operating input voltage	$I_O = 250\text{ mA}$			20	V
I_{out}	Output current limit			300		mA
ΔV_O	Line regulation	$V_I = 3.3\text{ to }20\text{ V}$, $I_O = 0.5\text{ mA}$		3	18	mV
ΔV_O	Load regulation ⁽¹⁾	$V_I = 3.5\text{ V}$, $I_O = 0.5\text{ to }250\text{ mA}$		3	18	mV
I_d	Quiescent current ON MODE	$V_I = 3.5\text{ to }20\text{ V}$, $I_O = 0\text{ mA}$		0.6	1	mA
		$V_I = 3.5\text{ to }20\text{ V}$, $I_O = 250\text{ mA}$		4	6	
	OFF MODE	$V_I = 6\text{ V}$		50	100	μA
SVR	Supply voltage rejection	$I_O = 5\text{ mA}$ $V_I = 4.4 \pm 1\text{ V}$	$f = 120\text{ Hz}$		75	dB
			$f = 1\text{ KHz}$		72	
			$f = 10\text{ KHz}$		55	
eN	Output noise voltage	$B = 10\text{ Hz to }100\text{ KHz}$		50		μV
V_d	Dropout voltage ⁽¹⁾	$I_O = 250\text{ mA}$		0.4	0.6	V
		$I_O = 250\text{ mA}$, $T_A = -40\text{ to }125\text{ }^\circ\text{C}$			0.8	V
V_{IL}	Control input logic low	$T_A = -40\text{ to }125\text{ }^\circ\text{C}$			0.8	V
V_{IH}	Control Input Logic High	$T_A = -40\text{ to }125\text{ }^\circ\text{C}$	2			V
I_I	Control input current	$V_I = 6\text{ V}$, $V_C = 6\text{ V}$		10		μA
C_O	Output bypass capacitance	$\text{ESR} = 0.1\text{ to }10\text{ }\Omega$, $I_O = 0\text{ to }250\text{ mA}$	2	10		μF

1. For SO-8 package the maximum limit of load regulation and dropout is increased by 20 mV.

Table 8. Electrical characteristics of L4931ABxx27 (refer to the test circuits, $T_A = 25\text{ }^\circ\text{C}$, $C_I = 0.1\text{ }\mu\text{F}$, $C_O = 2.2\text{ }\mu\text{F}$ unless otherwise specified).

Symbol	Parameter	Test conditions	Min.	Typ.	Max.	Unit
V_O	Output voltage	$I_O = 5\text{ mA}$, $V_I = 4.7\text{ V}$	2.673	2.7	2.727	V
		$I_O = 5\text{ mA}$, $V_I = 4.7\text{ V}$, $T_A = -25\text{ to }85\text{ }^\circ\text{C}$	2.646		2.754	
V_I	Operating input voltage	$I_O = 250\text{ mA}$			20	V
I_{out}	Output current limit			300		mA
ΔV_O	Line regulation	$V_I = 3.4\text{ to }20\text{ V}$, $I_O = 0.5\text{ mA}$		3	15	mV
ΔV_O	Load regulation ⁽¹⁾	$V_I = 3.6\text{ V}$, $I_O = 0.5\text{ to }250\text{ mA}$		3	15	mV
I_d	Quiescent current ON MODE	$V_I = 3.6\text{ to }20\text{ V}$, $I_O = 0\text{ mA}$		0.6	1	mA
		$V_I = 3.6\text{ to }20\text{ V}$, $I_O = 250\text{ mA}$		4	6	
	OFF MODE	$V_I = 6\text{ V}$		50	100	μA
SVR	Supply voltage rejection	$I_O = 5\text{ mA}$ $V_I = 4.6 \pm 1\text{ V}$	$f = 120\text{ Hz}$		74	dB
			$f = 1\text{ KHz}$		71	
			$f = 10\text{ KHz}$		55	
eN	Output noise voltage	$B = 10\text{ Hz to }100\text{ KHz}$		50		μV
V_d	Dropout voltage ⁽¹⁾	$I_O = 250\text{ mA}$		0.4	0.6	V
		$I_O = 250\text{ mA}$, $T_A = -40\text{ to }125\text{ }^\circ\text{C}$			0.8	V
V_{IL}	Control input logic low	$T_A = -40\text{ to }125\text{ }^\circ\text{C}$			0.8	V
V_{IH}	Control Input Logic High	$T_A = -40\text{ to }125\text{ }^\circ\text{C}$	2			V
I_I	Control input current	$V_I = 6\text{ V}$, $V_C = 6\text{ V}$		10		μA
C_O	Output bypass capacitance	$\text{ESR} = 0.1\text{ to }10\text{ }\Omega$, $I_O = 0\text{ to }250\text{ mA}$	2	10		μF

1. For SO-8 package the maximum limit of load regulation and dropout is increased by 20 mV.

Table 9. Electrical characteristics of L4931Cxx27 (refer to the test circuits, $T_A = 25^\circ\text{C}$, $C_I = 0.1\ \mu\text{F}$, $C_O = 2.2\ \mu\text{F}$ unless otherwise specified).

Symbol	Parameter	Test conditions	Min.	Typ.	Max.	Unit
V_O	Output voltage	$I_O = 5\ \text{mA}$, $V_I = 4.7\ \text{V}$	2.646	2.7	2.754	V
		$I_O = 5\ \text{mA}$, $V_I = 4.7\ \text{V}$, $T_A = -25\ \text{to}\ 85^\circ\text{C}$	2.592		2.808	
V_I	Operating input voltage	$I_O = 250\ \text{mA}$			20	V
I_{out}	Output current limit			300		mA
ΔV_O	Line regulation	$V_I = 3.4\ \text{to}\ 20\ \text{V}$, $I_O = 0.5\ \text{mA}$		3	18	mV
ΔV_O	Load regulation ⁽¹⁾	$V_I = 3.6\ \text{V}$, $I_O = 0.5\ \text{to}\ 250\ \text{mA}$		3	18	mV
I_d	Quiescent current ON MODE	$V_I = 3.6\ \text{to}\ 20\ \text{V}$, $I_O = 0\ \text{mA}$		0.6	1	mA
		$V_I = 3.6\ \text{to}\ 20\ \text{V}$, $I_O = 250\ \text{mA}$		4	6	
	OFF MODE	$V_I = 6\ \text{V}$		50	100	μA
SVR	Supply voltage rejection	$I_O = 5\ \text{mA}$ $V_I = 4.6 \pm 1\ \text{V}$	$f = 120\ \text{Hz}$		74	dB
			$f = 1\ \text{KHz}$		71	
			$f = 10\ \text{KHz}$		55	
eN	Output noise voltage	$B = 10\ \text{Hz to}\ 100\ \text{KHz}$		50		μV
V_d	Dropout voltage ⁽¹⁾	$I_O = 250\ \text{mA}$		0.4	0.6	V
		$I_O = 250\ \text{mA}$, $T_A = -40\ \text{to}\ 125^\circ\text{C}$			0.8	V
V_{IL}	Control input logic low	$T_A = -40\ \text{to}\ 125^\circ\text{C}$			0.8	V
V_{IH}	Control Input Logic High	$T_A = -40\ \text{to}\ 125^\circ\text{C}$	2			V
I_I	Control input current	$V_I = 6\ \text{V}$, $V_C = 6\ \text{V}$		10		μA
C_O	Output bypass capacitance	$\text{ESR} = 0.1\ \text{to}\ 10\ \Omega$, $I_O = 0\ \text{to}\ 250\ \text{mA}$	2	10		μF

1. For SO-8 package the maximum limit of load regulation and dropout is increased by 20 mV.

Table 10. Electrical characteristics of L4931Cxx27-TRY (Automotive Grade) (refer to the test circuits, $T_A = -40$ to 125°C , $C_I = 0.1 \mu\text{F}$, $C_O = 2.2 \mu\text{F}$ unless otherwise specified).

Symbol	Parameter	Test conditions	Min.	Typ.	Max.	Unit
V_O	Output voltage	$I_O = 5 \text{ mA}$, $V_I = 4.7 \text{ V}$, $T_A = 25^\circ\text{C}$	2.646	2.7	2.754	V
		$I_O = 5 \text{ mA}$, $V_I = 4.7 \text{ V}$	2.592		2.808	
V_I	Operating input voltage	$I_O = 250 \text{ mA}$			20	V
I_{out}	Output current limit	$T_A = 25^\circ\text{C}$		300		mA
ΔV_O	Line regulation	$V_I = 3.4$ to 20 V , $I_O = 0.5 \text{ mA}$			20	mV
ΔV_O	Load regulation	$V_I = 3.6 \text{ V}$, $I_O = 0.5$ to 250 mA			38	mV
I_d	Quiescent current ON MODE	$V_I = 3.6$ to 20 V , $I_O = 0 \text{ mA}$			1	mA
		$V_I = 3.6$ to 20 V , $I_O = 250 \text{ mA}$			6	
	OFF MODE	$V_I = 6 \text{ V}$			100	μA
SVR	Supply voltage rejection	$I_O = 5 \text{ mA}$ $V_I = 4.6 \pm 1 \text{ V}$ $T_A = 25^\circ\text{C}$	$f = 120 \text{ Hz}$		74	dB
			$f = 1 \text{ KHz}$		71	
			$f = 10 \text{ KHz}$		55	
eN	Output noise voltage	$B = 10 \text{ Hz}$ to 100 KHz , $T_A = 25^\circ\text{C}$		50		μV
V_d	Dropout voltage	$I_O = 250 \text{ mA}$, $T_A = 25^\circ\text{C}$		0.4	0.6	V
		$I_O = 250 \text{ mA}$			0.82	V
V_{IL}	Control input logic low				0.82	V
V_{IH}	Control Input Logic High		2			V
I_I	Control input current	$V_I = 6 \text{ V}$, $V_C = 6 \text{ V}$, $T_A = 25^\circ\text{C}$		10		μA
C_O	Output bypass capacitance	ESR = 0.1 to 10Ω , $I_O = 0$ to 250 mA , $T_A = 25^\circ\text{C}$	2	10		μF

Table 11. Electrical characteristics of L4931ABxx33 (refer to the test circuits, $T_A = 25\text{ }^\circ\text{C}$, $C_I = 0.1\text{ }\mu\text{F}$, $C_O = 2.2\text{ }\mu\text{F}$ unless otherwise specified).

Symbol	Parameter	Test conditions	Min.	Typ.	Max.	Unit
V_O	Output voltage	$I_O = 5\text{ mA}$, $V_I = 5.3\text{ V}$	3.267	3.3	3.333	V
		$I_O = 5\text{ mA}$, $V_I = 5.3\text{ V}$, $T_A = -25\text{ to }85\text{ }^\circ\text{C}$	3.234		3.366	
V_I	Operating input voltage	$I_O = 250\text{ mA}$			20	V
I_{out}	Output current limit			300		mA
ΔV_O	Line regulation	$V_I = 4\text{ to }20\text{ V}$, $I_O = 0.5\text{ mA}$		3	15	mV
ΔV_O	Load regulation ⁽¹⁾	$V_I = 4.2\text{ V}$, $I_O = 0.5\text{ to }250\text{ mA}$		3	15	mV
I_d	Quiescent current ON MODE	$V_I = 4.2\text{ to }20\text{ V}$, $I_O = 0\text{ mA}$		0.6	1	mA
		$V_I = 4.2\text{ to }20\text{ V}$, $I_O = 250\text{ mA}$		4	6	
	OFF MODE	$V_I = 6\text{ V}$		50	100	μA
SVR	Supply voltage rejection	$I_O = 5\text{ mA}$ $V_I = 5.2 \pm 1\text{ V}$	$f = 120\text{ Hz}$		73	dB
			$f = 1\text{ KHz}$		70	
			$f = 10\text{ KHz}$		55	
eN	Output noise voltage	$B = 10\text{ Hz to }100\text{ KHz}$		50		μV
V_d	Dropout voltage ⁽¹⁾	$I_O = 250\text{ mA}$		0.4	0.6	V
		$I_O = 250\text{ mA}$, $T_A = -40\text{ to }125\text{ }^\circ\text{C}$			0.8	V
V_{IL}	Control input logic low	$T_A = -40\text{ to }125\text{ }^\circ\text{C}$			0.8	V
V_{IH}	Control Input Logic High	$T_A = -40\text{ to }125\text{ }^\circ\text{C}$	2			V
I_I	Control input current	$V_I = 6\text{ V}$, $V_C = 6\text{ V}$		10		μA
C_O	Output bypass capacitance	$\text{ESR} = 0.1\text{ to }10\text{ }\Omega$, $I_O = 0\text{ to }250\text{ mA}$	2	10		μF

1. For SO-8 package the maximum limit of load regulation and dropout is increased by 20 mV.

Table 12. Electrical characteristics of L4931Cxx33 (refer to the test circuits, $T_A = 25\text{ }^\circ\text{C}$, $C_I = 0.1\text{ }\mu\text{F}$, $C_O = 2.2\text{ }\mu\text{F}$ unless otherwise specified).

Symbol	Parameter	Test conditions	Min.	Typ.	Max.	Unit
V_O	Output voltage	$I_O = 5\text{ mA}$, $V_I = 5.3\text{ V}$	3.234	3.3	3.366	V
		$I_O = 5\text{ mA}$, $V_I = 5.3\text{ V}$, $T_A = -25\text{ to }85\text{ }^\circ\text{C}$	3.168		3.432	
V_I	Operating input voltage	$I_O = 250\text{ mA}$			20	V
I_{out}	Output current limit			300		mA
ΔV_O	Line regulation	$V_I = 4.1\text{ to }20\text{ V}$, $I_O = 0.5\text{ mA}$		3	18	mV
ΔV_O	Load regulation ⁽¹⁾	$V_I = 4.3\text{ V}$, $I_O = 0.5\text{ to }250\text{ mA}$		3	18	mV
I_d	Quiescent current ON MODE	$V_I = 4.3\text{ to }20\text{ V}$, $I_O = 0\text{ mA}$		0.6	1	mA
		$V_I = 4.3\text{ to }20\text{ V}$, $I_O = 250\text{ mA}$		4	6	
	OFF MODE	$V_I = 6\text{ V}$		50	100	μA
SVR	Supply voltage rejection	$I_O = 5\text{ mA}$ $V_I = 5.3 \pm 1\text{ V}$	$f = 120\text{ Hz}$		73	dB
			$f = 1\text{ KHz}$		70	
			$f = 10\text{ KHz}$		55	
eN	Output noise voltage	$B = 10\text{ Hz to }100\text{ KHz}$		50		μV
V_d	Dropout voltage ⁽¹⁾	$I_O = 250\text{ mA}$		0.4	0.6	V
		$I_O = 250\text{ mA}$, $T_A = -40\text{ to }125\text{ }^\circ\text{C}$			0.8	V
V_{IL}	Control input logic low	$T_A = -40\text{ to }125\text{ }^\circ\text{C}$			0.8	V
V_{IH}	Control Input Logic High	$T_A = -40\text{ to }125\text{ }^\circ\text{C}$	2			V
I_I	Control input current	$V_I = 6\text{ V}$, $V_C = 6\text{ V}$		10		μA
C_O	Output bypass capacitance	$\text{ESR} = 0.1\text{ to }10\text{ }\Omega$, $I_O = 0\text{ to }250\text{ mA}$	2	10		μF

1. For SO-8 package the maximum limit of load regulation and dropout is increased by 20 mV.

Table 13. Electrical characteristics of L4931Cxx33-TRY (Automotive Grade) (refer to the test circuits, $T_A = -40$ to 125 °C, $C_I = 0.1$ μ F, $C_O = 2.2$ μ F unless otherwise specified).

Symbol	Parameter	Test conditions	Min.	Typ.	Max.	Unit
V_O	Output voltage	$I_O = 5$ mA, $V_I = 5.3$ V, $T_A = 25$ °C	3.234	3.3	3.366	V
		$I_O = 5$ mA, $V_I = 5.3$ V	3.168		3.432	
V_I	Operating input voltage	$I_O = 250$ mA			20	V
I_{out}	Output current limit	$T_A = 25$ °C		300		mA
ΔV_O	Line regulation	$V_I = 4.1$ to 20 V, $I_O = 0.5$ mA			20	mV
ΔV_O	Load regulation	$V_I = 4.3$ V, $I_O = 0.5$ to 250 mA			38	mV
I_d	Quiescent current ON MODE	$V_I = 4.3$ to 20 V, $I_O = 0$ mA			1	mA
		$V_I = 4.3$ to 20 V, $I_O = 250$ mA			6	
	OFF MODE	$V_I = 6$ V			100	μ A
SVR	Supply voltage rejection	$I_O = 5$ mA $V_I = 5.3 \pm 1$ V $T_A = 25$ °C	$f = 120$ Hz		73	dB
			$f = 1$ KHz		70	
			$f = 10$ KHz		55	
eN	Output noise voltage	$B = 10$ Hz to 100 KHz, $T_A = 25$ °C		50		μ V
V_d	Dropout voltage	$I_O = 250$ mA, $T_A = 25$ °C		0.4	0.6	V
		$I_O = 250$ mA			0.82	V
V_{IL}	Control input logic low				0.82	V
V_{IH}	Control Input Logic High		2			V
I_I	Control input current	$V_I = 6$ V, $V_C = 6$ V, $T_A = 25$ °C		10		μ A
C_O	Output bypass capacitance	ESR = 0.1 to 10 Ω , $I_O = 0$ to 250 mA, $T_A = 25$ °C	2	10		μ F

Table 14. Electrical characteristics of L4931ABxx35 (refer to the test circuits, $T_A = 25\text{ }^\circ\text{C}$, $C_I = 0.1\text{ }\mu\text{F}$, $C_O = 2.2\text{ }\mu\text{F}$ unless otherwise specified).

Symbol	Parameter	Test conditions	Min.	Typ.	Max.	Unit
V_O	Output voltage	$I_O = 5\text{ mA}$, $V_I = 5.5\text{ V}$	3.465	3.5	3.535	V
		$I_O = 5\text{ mA}$, $V_I = 5.5\text{ V}$, $T_A = -25\text{ to }85\text{ }^\circ\text{C}$	3.43		3.57	
V_I	Operating input voltage	$I_O = 250\text{ mA}$			20	V
I_{out}	Output current limit			300		mA
ΔV_O	Line regulation	$V_I = 4.2\text{ to }20\text{ V}$, $I_O = 0.5\text{ mA}$		3	15	mV
ΔV_O	Load regulation ⁽¹⁾	$V_I = 4.4\text{ V}$, $I_O = 0.5\text{ to }250\text{ mA}$		3	15	mV
I_d	Quiescent current ON MODE	$V_I = 4.4\text{ to }20\text{ V}$, $I_O = 0\text{ mA}$		0.6	1	mA
		$V_I = 4.4\text{ to }20\text{ V}$, $I_O = 250\text{ mA}$		4	6	
	OFF MODE	$V_I = 6\text{ V}$		50	100	μA
SVR	Supply voltage rejection	$I_O = 5\text{ mA}$ $V_I = 5.4 \pm 1\text{ V}$	$f = 120\text{ Hz}$		73	dB
			$f = 1\text{ KHz}$		70	
			$f = 10\text{ KHz}$		55	
eN	Output noise voltage	$B = 10\text{ Hz to }100\text{ KHz}$		50		μV
V_d	Dropout voltage ⁽¹⁾	$I_O = 250\text{ mA}$		0.4	0.6	V
		$I_O = 250\text{ mA}$, $T_A = -40\text{ to }125\text{ }^\circ\text{C}$			0.8	V
V_{IL}	Control input logic low	$T_A = -40\text{ to }125\text{ }^\circ\text{C}$			0.8	V
V_{IH}	Control Input Logic High	$T_A = -40\text{ to }125\text{ }^\circ\text{C}$	2			V
I_I	Control input current	$V_I = 6\text{ V}$, $V_C = 6\text{ V}$		10		μA
C_O	Output bypass capacitance	$\text{ESR} = 0.1\text{ to }10\text{ }\Omega$, $I_O = 0\text{ to }250\text{ mA}$	2	10		μF

1. For SO-8 package the maximum limit of load regulation and dropout is increased by 20 mV.

Table 15. Electrical characteristics of L4931ABxx35-TRY (Automotive Grade) (refer to the test circuits, $T_A = -40$ to 125 °C, $C_I = 0.1$ μ F, $C_O = 2.2$ μ F unless otherwise specified).

Symbol	Parameter	Test conditions	Min.	Typ.	Max.	Unit
V_O	Output voltage	$I_O = 5$ mA, $V_I = 5.5$ V, $T_A = 25$ °C	3.465	3.5	3.535	V
		$I_O = 5$ mA, $V_I = 5.5$ V	3.43		3.57	
V_I	Operating input voltage	$I_O = 250$ mA			20	V
I_{out}	Output current limit	$T_A = 25$ °C		300		mA
ΔV_O	Line regulation	$V_I = 4.2$ to 20 V, $I_O = 0.5$ mA			17	mV
ΔV_O	Load regulation	$V_I = 4.4$ V, $I_O = 0.5$ to 250 mA			35	mV
I_d	Quiescent current ON MODE	$V_I = 4.4$ to 20 V, $I_O = 0$ mA			1	mA
		$V_I = 4.4$ to 20 V, $I_O = 250$ mA			6	
	OFF MODE	$V_I = 6$ V			100	μ A
SVR	Supply voltage rejection	$I_O = 5$ mA $V_I = 5.4 \pm 1$ V $T_A = 25$ °C	$f = 120$ Hz		73	dB
			$f = 1$ KHz		70	
			$f = 10$ KHz		55	
eN	Output noise voltage	$B = 10$ Hz to 100 KHz, $T_A = 25$ °C		50		μ V
V_d	Dropout voltage	$I_O = 250$ mA, $T_A = 25$ °C		0.4	0.6	V
		$I_O = 250$ mA			0.82	V
V_{IL}	Control input logic low				0.82	V
V_{IH}	Control Input Logic High		2			V
I_I	Control input current	$V_I = 6$ V, $V_C = 6$ V, $T_A = 25$ °C		10		μ A
C_O	Output bypass capacitance	ESR = 0.1 to 10 Ω , $I_O = 0$ to 250 mA, $T_A = 25$ °C	2	10		μ F

Table 16. Electrical characteristics of L4931Cxx35 (refer to the test circuits, $T_A = 25\text{ }^\circ\text{C}$, $C_I = 0.1\text{ }\mu\text{F}$, $C_O = 2.2\text{ }\mu\text{F}$ unless otherwise specified).

Symbol	Parameter	Test conditions	Min.	Typ.	Max.	Unit
V_O	Output voltage	$I_O = 5\text{ mA}$, $V_I = 5.5\text{ V}$	3.43	3.5	3.57	V
		$I_O = 5\text{ mA}$, $V_I = 5.5\text{ V}$, $T_A = -25\text{ to }85\text{ }^\circ\text{C}$	3.36		3.64	
V_I	Operating input voltage	$I_O = 250\text{ mA}$			20	V
I_{out}	Output current limit			300		mA
ΔV_O	Line regulation	$V_I = 4.3\text{ to }20\text{ V}$, $I_O = 0.5\text{ mA}$		3	18	mV
ΔV_O	Load regulation ⁽¹⁾	$V_I = 4.5\text{ V}$, $I_O = 0.5\text{ to }250\text{ mA}$		3	18	mV
I_d	Quiescent current ON MODE	$V_I = 4.5\text{ to }20\text{ V}$, $I_O = 0\text{ mA}$		0.6	1	mA
		$V_I = 4.5\text{ to }20\text{ V}$, $I_O = 250\text{ mA}$		4	6	
	OFF MODE	$V_I = 6\text{ V}$		50	100	μA
SVR	Supply voltage rejection	$I_O = 5\text{ mA}$ $V_I = 5.5 \pm 1\text{ V}$	$f = 120\text{ Hz}$		73	dB
			$f = 1\text{ KHz}$		70	
			$f = 10\text{ KHz}$		55	
eN	Output noise voltage	$B = 10\text{ Hz to }100\text{ KHz}$		50		μV
V_d	Dropout voltage ⁽¹⁾	$I_O = 250\text{ mA}$		0.4	0.6	V
		$I_O = 250\text{ mA}$, $T_A = -40\text{ to }125\text{ }^\circ\text{C}$			0.8	V
V_{IL}	Control input logic low	$T_A = -40\text{ to }125\text{ }^\circ\text{C}$			0.8	V
V_{IH}	Control Input Logic High	$T_A = -40\text{ to }125\text{ }^\circ\text{C}$	2			V
I_I	Control input current	$V_I = 6\text{ V}$, $V_C = 6\text{ V}$		10		μA
C_O	Output bypass capacitance	$\text{ESR} = 0.1\text{ to }10\text{ }\Omega$, $I_O = 0\text{ to }250\text{ mA}$	2	10		μF

1. For SO-8 package the maximum limit of load regulation and dropout is increased by 20 mV.

Table 17. Electrical characteristics of L4931Cxx47 (refer to the test circuits, $T_A = 25^\circ\text{C}$, $C_I = 0.1\ \mu\text{F}$, $C_O = 2.2\ \mu\text{F}$ unless otherwise specified).

Symbol	Parameter	Test conditions	Min.	Typ.	Max.	Unit
V_O	Output voltage	$I_O = 5\ \text{mA}$, $V_I = 6.7\ \text{V}$	4.606	4.7	4.794	V
		$I_O = 5\ \text{mA}$, $V_I = 6.7\ \text{V}$, $T_A = -25\ \text{to}\ 85^\circ\text{C}$	4.512		4.888	
V_I	Operating input voltage	$I_O = 250\ \text{mA}$			20	V
I_{out}	Output current limit			300		mA
ΔV_O	Line regulation	$V_I = 5.5\ \text{to}\ 20\ \text{V}$, $I_O = 0.5\ \text{mA}$		3.5	21	mV
ΔV_O	Load regulation ⁽¹⁾	$V_I = 5.7\ \text{V}$, $I_O = 0.5\ \text{to}\ 250\ \text{mA}$		3	18	mV
I_d	Quiescent current ON MODE	$V_I = 5.7\ \text{to}\ 20\ \text{V}$, $I_O = 0\ \text{mA}$		0.6	1	mA
		$V_I = 5.7\ \text{to}\ 20\ \text{V}$, $I_O = 250\ \text{mA}$		4	6	
	OFF MODE	$V_I = 6\ \text{V}$		50	100	μA
SVR	Supply voltage rejection	$I_O = 5\ \text{mA}$ $V_I = 6.7 \pm 1\ \text{V}$	$f = 120\ \text{Hz}$		71	dB
			$f = 1\ \text{KHz}$		68	
			$f = 10\ \text{KHz}$		55	
eN	Output noise voltage	$B = 10\ \text{Hz to}\ 100\ \text{KHz}$		50		μV
V_d	Dropout voltage ⁽¹⁾	$I_O = 250\ \text{mA}$		0.4	0.6	V
		$I_O = 250\ \text{mA}$, $T_A = -40\ \text{to}\ 125^\circ\text{C}$			0.8	V
V_{IL}	Control input logic low	$T_A = -40\ \text{to}\ 125^\circ\text{C}$			0.8	V
V_{IH}	Control Input Logic High	$T_A = -40\ \text{to}\ 125^\circ\text{C}$	2			V
I_I	Control input current	$V_I = 6\ \text{V}$, $V_C = 6\ \text{V}$		10		μA
C_O	Output bypass capacitance	$\text{ESR} = 0.1\ \text{to}\ 10\ \Omega$, $I_O = 0\ \text{to}\ 250\ \text{mA}$	2	10		μF

1. For SO-8 package the maximum limit of load regulation and dropout is increased by 20 mV.

Table 18. Electrical characteristics of L4931ABxx50 (refer to the test circuits, $T_A = 25\text{ }^\circ\text{C}$, $C_I = 0.1\text{ }\mu\text{F}$, $C_O = 2.2\text{ }\mu\text{F}$ unless otherwise specified).

Symbol	Parameter	Test conditions	Min.	Typ.	Max.	Unit
V_O	Output voltage	$I_O = 5\text{ mA}$, $V_I = 7\text{ V}$	4.95	5	5.05	V
		$I_O = 5\text{ mA}$, $V_I = 7\text{ V}$, $T_A = -25\text{ to }85\text{ }^\circ\text{C}$	4.9		5.1	
V_I	Operating input voltage	$I_O = 250\text{ mA}$			20	V
I_{out}	Output current limit			300		mA
ΔV_O	Line regulation	$V_I = 5.8\text{ to }20\text{ V}$, $I_O = 0.5\text{ mA}$		3.5	17.5	mV
ΔV_O	Load regulation ⁽¹⁾	$V_I = 6\text{ V}$, $I_O = 0.5\text{ to }250\text{ mA}$		3	15	mV
I_d	Quiescent current ON MODE	$V_I = 6\text{ to }20\text{ V}$, $I_O = 0\text{ mA}$		0.6	1	mA
		$V_I = 6\text{ to }20\text{ V}$, $I_O = 250\text{ mA}$		4	6	
	OFF MODE	$V_I = 6\text{ V}$		50	100	μA
SVR	Supply voltage rejection	$I_O = 5\text{ mA}$ $V_I = 7 \pm 1\text{ V}$	$f = 120\text{ Hz}$		70	dB
			$f = 1\text{ KHz}$		67	
			$f = 10\text{ KHz}$		55	
eN	Output noise voltage	$B = 10\text{ Hz to }100\text{ KHz}$		50		μV
V_d	Dropout voltage ⁽¹⁾	$I_O = 250\text{ mA}$		0.4	0.6	V
		$I_O = 250\text{ mA}$, $T_A = -40\text{ to }125\text{ }^\circ\text{C}$			0.8	V
V_{IL}	Control input logic low	$T_A = -40\text{ to }125\text{ }^\circ\text{C}$			0.8	V
V_{IH}	Control Input Logic High	$T_A = -40\text{ to }125\text{ }^\circ\text{C}$	2			V
I_I	Control input current	$V_I = 6\text{ V}$, $V_C = 6\text{ V}$		10		μA
C_O	Output bypass capacitance	$\text{ESR} = 0.1\text{ to }10\text{ }\Omega$, $I_O = 0\text{ to }250\text{ mA}$	2	10		μF

1. For SO-8 package the maximum limit of load regulation and dropout is increased by 20 mV.

Table 19. Electrical characteristics of L4931Cxx50 (refer to the test circuits, $T_A = 25^\circ\text{C}$, $C_I = 0.1\ \mu\text{F}$, $C_O = 2.2\ \mu\text{F}$ unless otherwise specified).

Symbol	Parameter	Test conditions	Min.	Typ.	Max.	Unit
V_O	Output voltage	$I_O = 5\ \text{mA}$, $V_I = 7\ \text{V}$	4.9	5	5.1	V
		$I_O = 5\ \text{mA}$, $V_I = 7\ \text{V}$, $T_A = -25\ \text{to}\ 85^\circ\text{C}$	4.8		5.2	
V_I	Operating input voltage	$I_O = 250\ \text{mA}$			20	V
I_{out}	Output current limit			300		mA
ΔV_O	Line regulation	$V_I = 5.8\ \text{to}\ 20\ \text{V}$, $I_O = 0.5\ \text{mA}$		3.5	17.5	mV
ΔV_O	Load regulation ⁽¹⁾	$V_I = 6\ \text{V}$, $I_O = 0.5\ \text{to}\ 250\ \text{mA}$		3	15	mV
I_d	Quiescent current ON MODE	$V_I = 6\ \text{to}\ 20\ \text{V}$, $I_O = 0\ \text{mA}$		0.6	1	mA
		$V_I = 6\ \text{to}\ 20\ \text{V}$, $I_O = 250\ \text{mA}$		4	6	
	OFF MODE	$V_I = 6\ \text{V}$		50	100	μA
SVR	Supply voltage rejection	$I_O = 5\ \text{mA}$ $V_I = 7 \pm 1\ \text{V}$	$f = 120\ \text{Hz}$		70	dB
			$f = 1\ \text{KHz}$		67	
			$f = 10\ \text{KHz}$		55	
eN	Output noise voltage	$B = 10\ \text{Hz to}\ 100\ \text{KHz}$		50		μV
V_d	Dropout voltage ⁽¹⁾	$I_O = 250\ \text{mA}$		0.4	0.6	V
		$I_O = 250\ \text{mA}$, $T_A = -40\ \text{to}\ 125^\circ\text{C}$			0.8	V
V_{IL}	Control input logic low	$T_A = -40\ \text{to}\ 125^\circ\text{C}$			0.8	V
V_{IH}	Control Input Logic High	$T_A = -40\ \text{to}\ 125^\circ\text{C}$	2			V
I_I	Control input current	$V_I = 6\ \text{V}$, $V_C = 6\ \text{V}$		10		μA
C_O	Output bypass capacitance	$\text{ESR} = 0.1\ \text{to}\ 10\ \Omega$, $I_O = 0\ \text{to}\ 250\ \text{mA}$	2	10		μF

1. For SO-8 package the maximum limit of load regulation and dropout is increased by 20 mV.

Table 20. Electrical characteristics of L4931ABxx80 (refer to the test circuits, $T_A = 25\text{ }^\circ\text{C}$, $C_I = 0.1\text{ }\mu\text{F}$, $C_O = 2.2\text{ }\mu\text{F}$ unless otherwise specified).

Symbol	Parameter	Test conditions	Min.	Typ.	Max.	Unit
V_O	Output voltage	$I_O = 5\text{ mA}$, $V_I = 10\text{ V}$	7.92	8	8.08	V
		$I_O = 5\text{ mA}$, $V_I = 10\text{ V}$, $T_A = -25\text{ to }85\text{ }^\circ\text{C}$	7.84		8.16	
V_I	Operating input voltage	$I_O = 250\text{ mA}$			20	V
I_{out}	Output current limit			300		mA
ΔV_O	Line regulation	$V_I = 8.8\text{ to }20\text{ V}$, $I_O = 0.5\text{ mA}$		4	20	mV
ΔV_O	Load regulation ⁽¹⁾	$V_I = 9\text{ V}$, $I_O = 0.5\text{ to }250\text{ mA}$		3	15	mV
I_d	Quiescent current ON MODE	$V_I = 9\text{ to }20\text{ V}$, $I_O = 0\text{ mA}$		0.8	1.6	mA
		$V_I = 9\text{ to }20\text{ V}$, $I_O = 250\text{ mA}$		4.5	7	
	OFF MODE	$V_I = 6\text{ V}$		70	140	μA
SVR	Supply voltage rejection	$I_O = 5\text{ mA}$ $V_I = 10 \pm 1\text{ V}$	$f = 120\text{ Hz}$		67	dB
			$f = 1\text{ KHz}$		64	
			$f = 10\text{ KHz}$		55	
eN	Output noise voltage	$B = 10\text{ Hz to }100\text{ KHz}$		50		μV
V_d	Dropout voltage ⁽¹⁾	$I_O = 250\text{ mA}$		0.4	0.6	V
		$I_O = 250\text{ mA}$, $T_A = -40\text{ to }125\text{ }^\circ\text{C}$			0.8	V
V_{IL}	Control input logic low	$T_A = -40\text{ to }125\text{ }^\circ\text{C}$			0.8	V
V_{IH}	Control Input Logic High	$T_A = -40\text{ to }125\text{ }^\circ\text{C}$	2			V
I_I	Control input current	$V_I = 6\text{ V}$, $V_C = 6\text{ V}$		10		μA
C_O	Output bypass capacitance	$\text{ESR} = 0.1\text{ to }10\text{ }\Omega$, $I_O = 0\text{ to }250\text{ mA}$	2	10		μF

1. For SO-8 package the maximum limit of load regulation and dropout is increased by 20 mV.

Table 21. Electrical characteristics of L4931Cxx80 (refer to the test circuits, $T_A = 25\text{ }^\circ\text{C}$, $C_I = 0.1\text{ }\mu\text{F}$, $C_O = 2.2\text{ }\mu\text{F}$ unless otherwise specified).

Symbol	Parameter	Test conditions	Min.	Typ.	Max.	Unit
V_O	Output voltage	$I_O = 5\text{ mA}$, $V_I = 10\text{ V}$	7.84	8	8.16	V
		$I_O = 5\text{ mA}$, $V_I = 10\text{ V}$, $T_A = -25\text{ to }85\text{ }^\circ\text{C}$	7.68		8.32	
V_I	Operating input voltage	$I_O = 250\text{ mA}$			20	V
I_{out}	Output current limit			300		mA
ΔV_O	Line regulation	$V_I = 8.9\text{ to }20\text{ V}$, $I_O = 0.5\text{ mA}$		4	24	mV
ΔV_O	Load regulation ⁽¹⁾	$V_I = 9.1\text{ V}$, $I_O = 0.5\text{ to }250\text{ mA}$		3	18	mV
I_d	Quiescent current ON MODE	$V_I = 9.1\text{ to }20\text{ V}$, $I_O = 0\text{ mA}$		0.8	1.6	mA
		$V_I = 9.1\text{ to }20\text{ V}$, $I_O = 250\text{ mA}$		4.5	7	
	OFF MODE	$V_I = 6\text{ V}$		70	140	μA
SVR	Supply voltage rejection	$I_O = 5\text{ mA}$ $V_I = 10.1 \pm 1\text{ V}$	$f = 120\text{ Hz}$		67	dB
			$f = 1\text{ KHz}$		64	
			$f = 10\text{ KHz}$		55	
eN	Output noise voltage	$B = 10\text{ Hz to }100\text{ KHz}$		50		μV
V_d	Dropout voltage ⁽¹⁾	$I_O = 250\text{ mA}$		0.4	0.6	V
		$I_O = 250\text{ mA}$, $T_A = -40\text{ to }125\text{ }^\circ\text{C}$			0.8	V
V_{IL}	Control input logic low	$T_A = -40\text{ to }125\text{ }^\circ\text{C}$			0.8	V
V_{IH}	Control Input Logic High	$T_A = -40\text{ to }125\text{ }^\circ\text{C}$	2			V
I_I	Control input current	$V_I = 6\text{ V}$, $V_C = 6\text{ V}$		10		μA
C_O	Output bypass capacitance	$\text{ESR} = 0.1\text{ to }10\text{ }\Omega$, $I_O = 0\text{ to }250\text{ mA}$	2	10		μF

1. For SO-8 package the maximum limit of load regulation and dropout is increased by 20 mV.

Table 22. Electrical characteristics of L4931ABxx120 (refer to the test circuits, $T_A = 25\text{ }^\circ\text{C}$, $C_I = 0.1\text{ }\mu\text{F}$, $C_O = 2.2\text{ }\mu\text{F}$ unless otherwise specified).

Symbol	Parameter	Test conditions	Min.	Typ.	Max.	Unit
V_O	Output voltage	$I_O = 5\text{ mA}$, $V_I = 14\text{ V}$	11.88	12	12.12	V
		$I_O = 5\text{ mA}$, $V_I = 14\text{ V}$, $T_A = -25\text{ to }85\text{ }^\circ\text{C}$	11.76		12.24	
V_I	Operating input voltage	$I_O = 250\text{ mA}$			20	V
I_{out}	Output current limit			300		mA
ΔV_O	Line regulation	$V_I = 12.8\text{ to }20\text{ V}$, $I_O = 0.5\text{ mA}$		4	20	mV
ΔV_O	Load regulation ⁽¹⁾	$V_I = 13\text{ V}$, $I_O = 0.5\text{ to }250\text{ mA}$		3	15	mV
I_d	Quiescent current ON MODE	$V_I = 13\text{ to }20\text{ V}$, $I_O = 0\text{ mA}$		0.8	1.6	mA
		$V_I = 13\text{ to }20\text{ V}$, $I_O = 250\text{ mA}$		4.5	7	
	OFF MODE	$V_I = 6\text{ V}$		90	180	μA
SVR	Supply voltage rejection	$I_O = 5\text{ mA}$ $V_I = 14 \pm 1\text{ V}$	$f = 120\text{ Hz}$		64	dB
			$f = 1\text{ KHz}$		61	
			$f = 10\text{ KHz}$		55	
eN	Output noise voltage	$B = 10\text{ Hz to }100\text{ KHz}$		50		μV
V_d	Dropout voltage ⁽¹⁾	$I_O = 250\text{ mA}$		0.4	0.6	V
		$I_O = 250\text{ mA}$, $T_A = -40\text{ to }125\text{ }^\circ\text{C}$			0.8	V
V_{IL}	Control input logic low	$T_A = -40\text{ to }125\text{ }^\circ\text{C}$			0.8	V
V_{IH}	Control Input Logic High	$T_A = -40\text{ to }125\text{ }^\circ\text{C}$	2			V
I_I	Control input current	$V_I = 6\text{ V}$, $V_C = 6\text{ V}$		10		μA
C_O	Output bypass capacitance	$\text{ESR} = 0.1\text{ to }10\text{ }\Omega$, $I_O = 0\text{ to }250\text{ mA}$	2	10		μF

1. For SO-8 package the maximum limit of load regulation and dropout is increased by 20 mV.

Table 23. Electrical characteristics of L4931Cxx120 (refer to the test circuits, $T_A = 25\text{ }^\circ\text{C}$, $C_I = 0.1\text{ }\mu\text{F}$, $C_O = 2.2\text{ }\mu\text{F}$ unless otherwise specified).

Symbol	Parameter	Test conditions	Min.	Typ.	Max.	Unit
V_O	Output voltage	$I_O = 5\text{ mA}$, $V_I = 14\text{ V}$	11.76	12	12.24	V
		$I_O = 5\text{ mA}$, $V_I = 14\text{ V}$, $T_A = -25\text{ to }85\text{ }^\circ\text{C}$	11.52		12.48	
V_I	Operating input voltage	$I_O = 250\text{ mA}$			20	V
I_{out}	Output current limit			300		mA
ΔV_O	Line regulation	$V_I = 12.9\text{ to }20\text{ V}$, $I_O = 0.5\text{ mA}$		4	24	mV
ΔV_O	Load regulation ⁽¹⁾	$V_I = 13.1\text{ V}$, $I_O = 0.5\text{ to }250\text{ mA}$		3	18	mV
I_d	Quiescent current ON MODE	$V_I = 13.1\text{ to }20\text{ V}$, $I_O = 0\text{ mA}$		0.8	1.6	mA
		$V_I = 13.1\text{ to }20\text{ V}$, $I_O = 250\text{ mA}$		4.5	7	
	OFF MODE	$V_I = 6\text{ V}$		90	180	μA
SVR	Supply voltage rejection	$I_O = 5\text{ mA}$ $V_I = 14.1 \pm 1\text{ V}$	$f = 120\text{ Hz}$		64	dB
			$f = 1\text{ KHz}$		61	
			$f = 10\text{ KHz}$		55	
eN	Output noise voltage	$B = 10\text{ Hz to }100\text{ KHz}$		50		μV
V_d	Dropout voltage ⁽¹⁾	$I_O = 250\text{ mA}$		0.4	0.6	V
		$I_O = 250\text{ mA}$, $T_A = -40\text{ to }125\text{ }^\circ\text{C}$			0.8	V
V_{IL}	Control input logic low	$T_A = -40\text{ to }125\text{ }^\circ\text{C}$			0.8	V
V_{IH}	Control Input Logic High	$T_A = -40\text{ to }125\text{ }^\circ\text{C}$	2			V
I_I	Control input current	$V_I = 6\text{ V}$, $V_C = 6\text{ V}$		10		μA
C_O	Output bypass capacitance	$\text{ESR} = 0.1\text{ to }10\text{ }\Omega$, $I_O = 0\text{ to }250\text{ mA}$	2	10		μF

1. For SO-8 package the maximum limit of load regulation and dropout is increased by 20 mV.

6 Typical application

Figure 4. Line regulation vs temperature

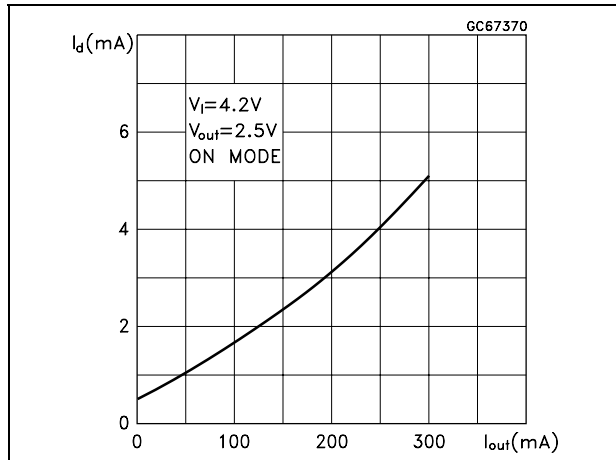

Figure 5. Dropout voltage vs temperature

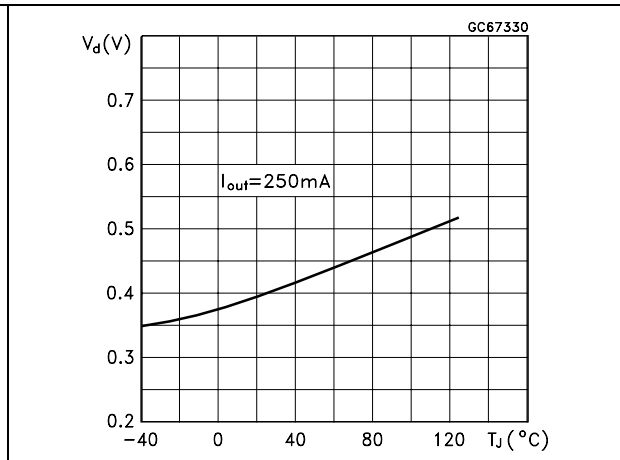

Figure 6. Supply current vs input voltage

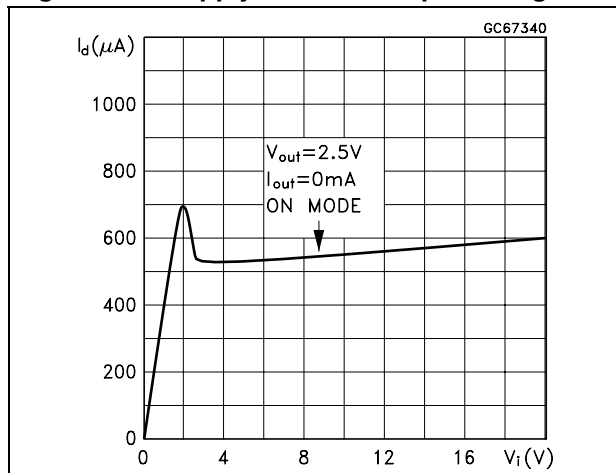

Figure 7. Supply current vs temperature

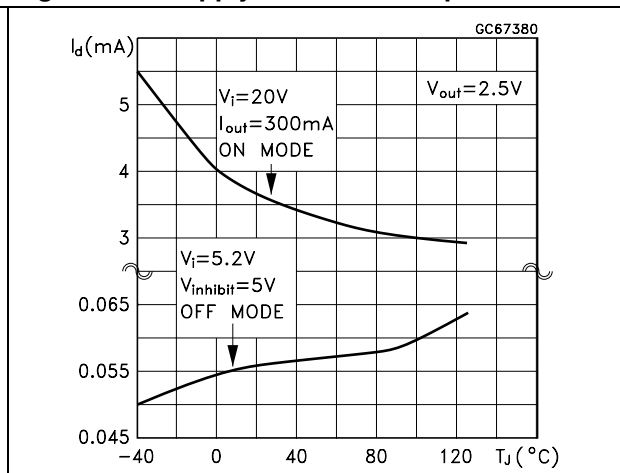

Figure 8. Short circuit current vs dropout voltage

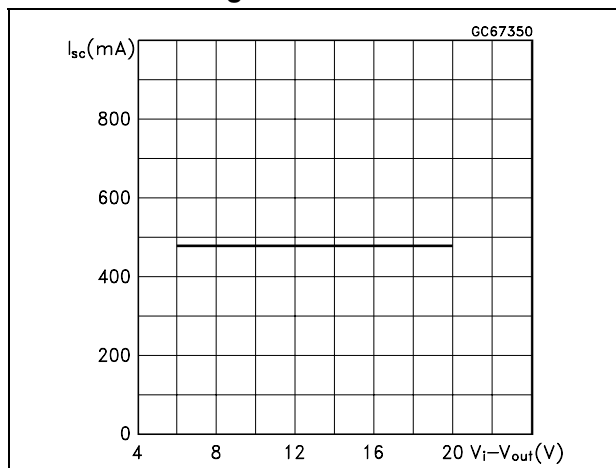
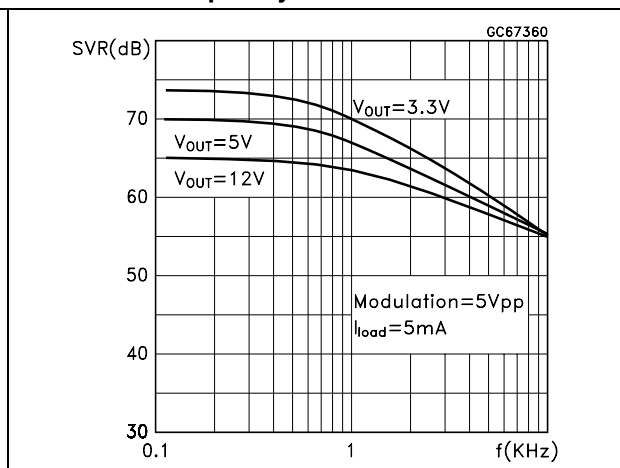

Figure 9. S.V.R. vs Input voltage signal frequency



7 Package mechanical data

In order to meet environmental requirements, ST offers these devices in ECOPACK® packages. These packages have a lead-free second level interconnect. The category of second Level Interconnect is marked on the package and on the inner box label, in compliance with JEDEC Standard JESD97. The maximum ratings related to soldering conditions are also marked on the inner box label. ECOPACK is an ST trademark. ECOPACK specifications are available at: www.st.com.

TO-220 mechanical data

Dim.	mm.			inch.		
	Min.	Typ.	Max.	Min.	Typ.	Max.
A	4.40		4.60	0.173		0.181
C	1.23		1.32	0.048		0.051
D	2.40		2.72	0.094		0.107
D1		1.27			0.050	
E	0.49		0.70	0.019		0.027
F	0.61		0.88	0.024		0.034
F1	1.14		1.70	0.044		0.067
F2	1.14		1.70	0.044		0.067
G	4.95		5.15	0.194		0.203
G1	2.4		2.7	0.094		0.106
H2	10.0		10.40	0.393		0.409
L2		16.4			0.645	
L4	13.0		14.0	0.511		0.551
L5	2.65		2.95	0.104		0.116
L6	15.25		15.75	0.600		0.620
L7	6.2		6.6	0.244		0.260
L9	3.5		3.93	0.137		0.154
DIA.	3.75		3.85	0.147		0.151

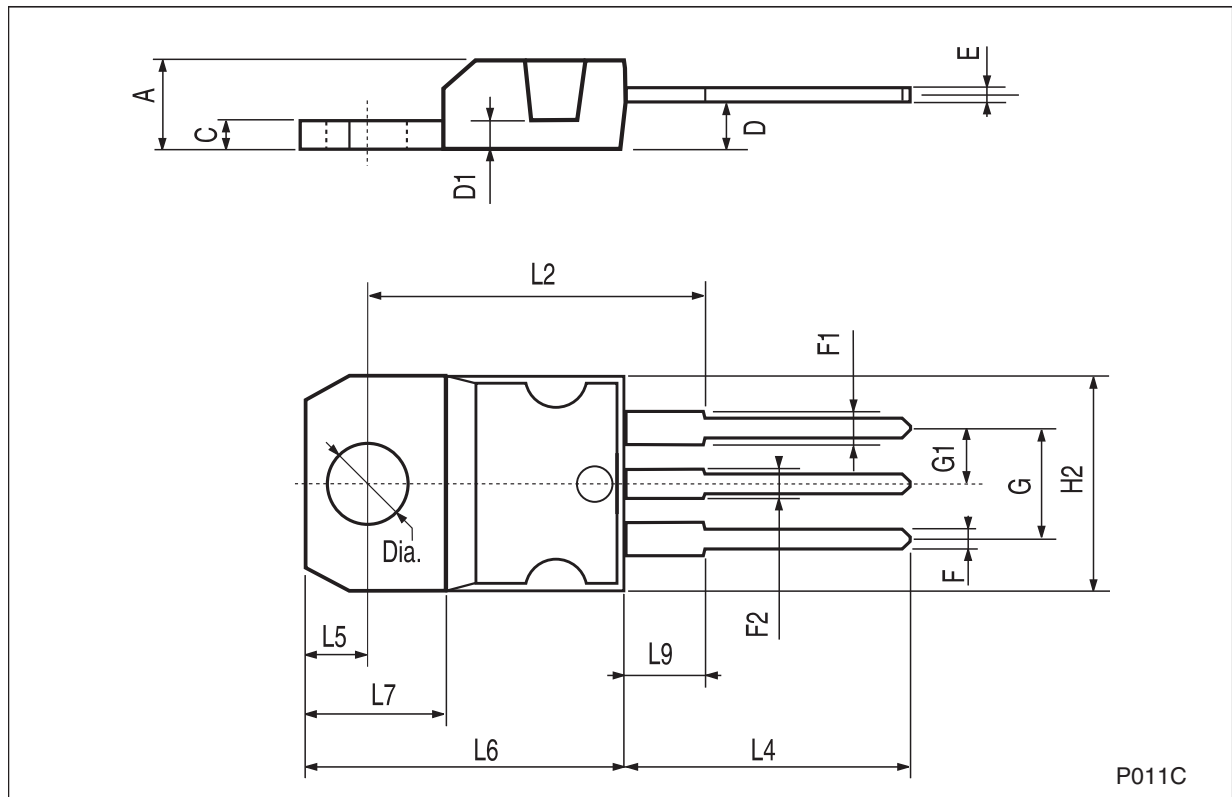

P011C

TO-92 mechanical data

Dim.	mm.			mils.		
	Min.	Typ.	Max.	Min.	Typ.	Max.
A	4.32		4.95	170.1		194.9
b	0.36		0.51	14.2		20.1
D	4.45		4.95	175.2		194.9
E	3.30		3.94	129.9		155.1
e	2.41		2.67	94.9		105.1
e1	1.14		1.40	44.9		55.1
L	12.7		15.49	500.0		609.8
R	2.16		2.41	85.0		94.9
S1	0.92		1.52	36.2		59.8
W	0.41		0.56	16.1		22.0
α		5°			5°	

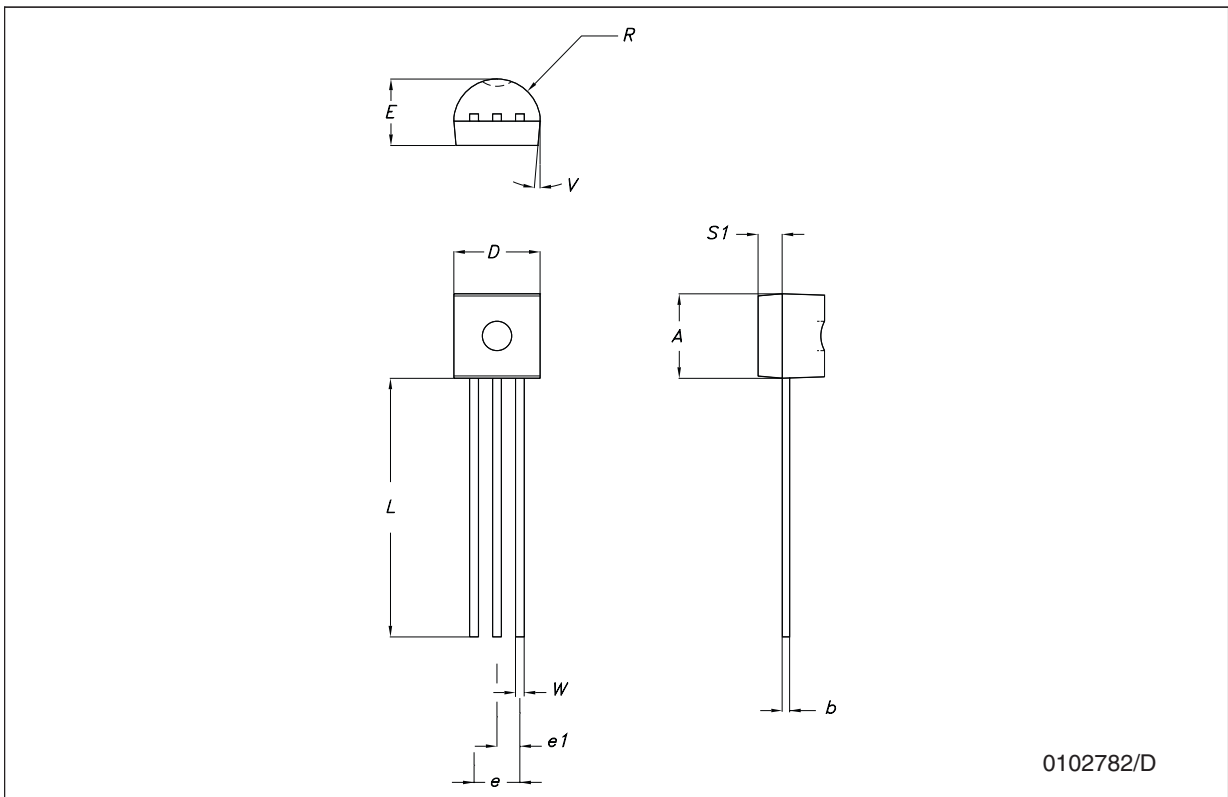

PPAK mechanical data

Dim.	mm.			inch.		
	Min.	Typ.	Max.	Min.	Typ.	Max.
A	2.2		2.4	0.086		0.094
A1	0.9		1.1	0.035		0.043
A2	0.03		0.23	0.001		0.009
B	0.4		0.6	0.015		0.023
B2	5.2		5.4	0.204		0.212
C	0.45		0.6	0.017		0.023
C2	0.48		0.6	0.019		0.023
D	6		6.2	0.236		0.244
D1		5.1			0.201	
E	6.4		6.6	0.252		0.260
E1		4.7			0.185	
e		1.27			0.050	
G	4.9		5.25	0.193		0.206
G1	2.38		2.7	0.093		0.106
H	9.35		10.1	0.368		0.397
L2		0.8	1		0.031	0.039
L4	0.6		1	0.023		0.039
L5	1			0.039		
L6		2.8			0.110	

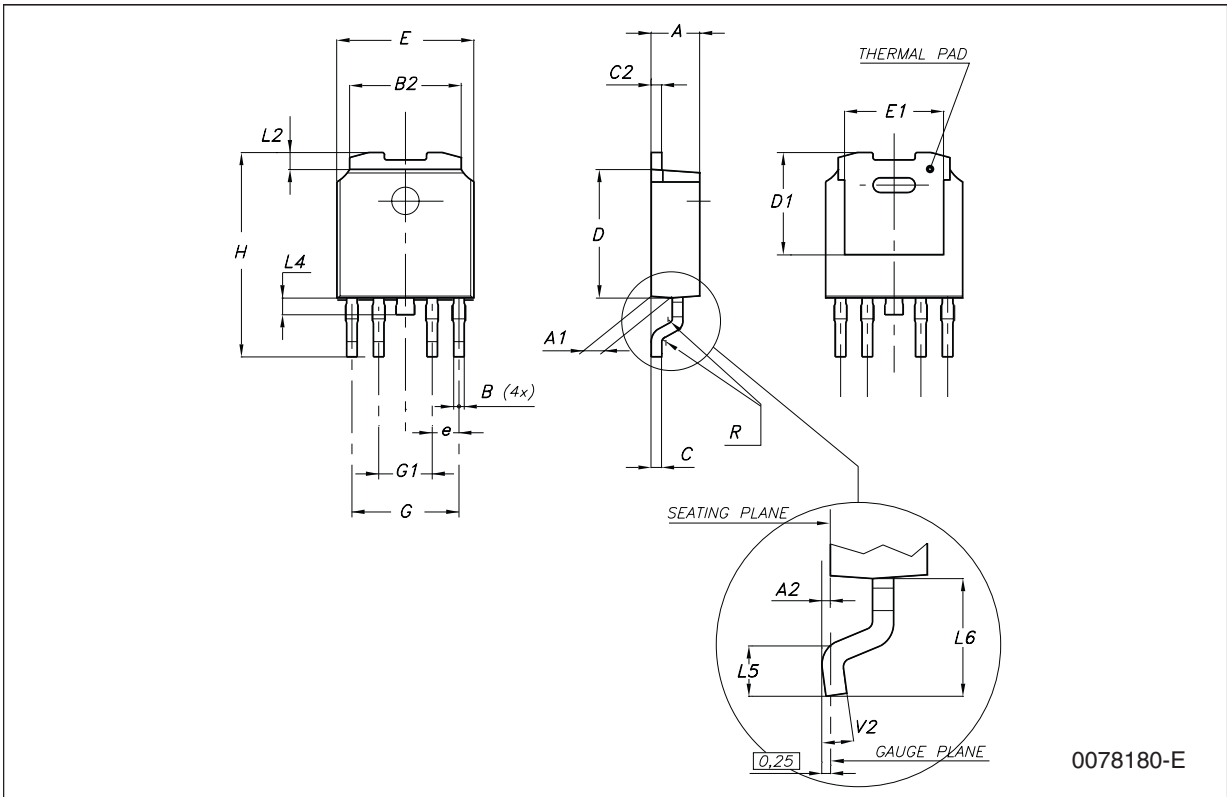

0078180-E

DPAK mechanical data

Dim.	mm.			inch.		
	Min.	Typ.	Max.	Min.	Typ.	Max.
A	2.2		2.4	0.086		0.094
A1	0.9		1.1	0.035		0.043
A2	0.03		0.23	0.001		0.009
B	0.64		0.9	0.025		0.035
b4	5.2		5.4	0.204		0.212
C	0.45		0.6	0.017		0.023
C2	0.48		0.6	0.019		0.023
D	6		6.2	0.236		0.244
D1		5.1			0.200	
E	6.4		6.6	0.252		0.260
E1		4.7			0.185	
e		2.28			0.090	
e1	4.4		4.6	0.173		0.181
H	9.35		10.1	0.368		0.397
L	1			0.039		
(L1)		2.8			0.110	
L2		0.8			0.031	
L4	0.6		1	0.023		0.039
R		0.2			0.008	
V2	0°		8°	0°		8°

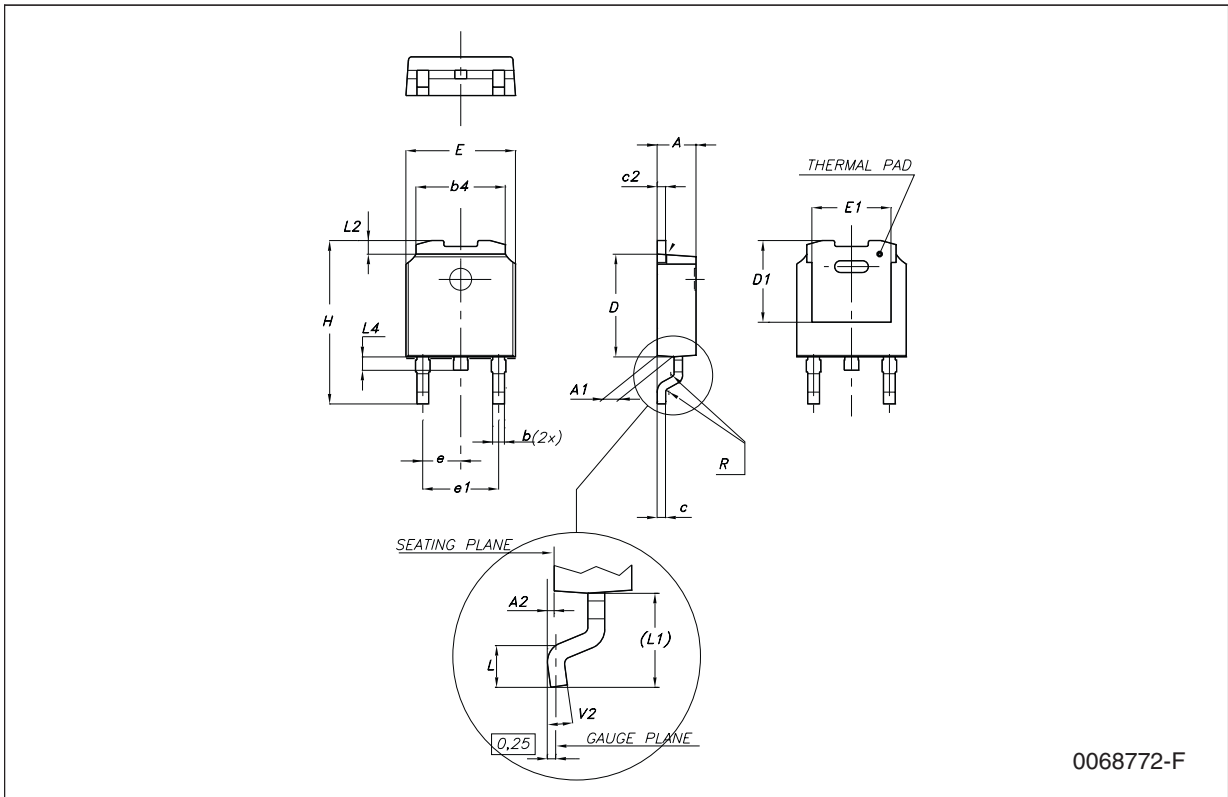

0068772-F

SO-8 mechanical data

Dim.	mm.			inch.		
	Min.	Typ.	Max.	Min.	Typ.	Max.
A	1.35		1.75	0.053		0.069
A1	0.10		0.25	0.04		0.010
A2	1.10		1.65	0.043		0.065
B	0.33		0.51	0.013		0.020
C	0.19		0.25	0.007		0.010
D	4.80		5.00	0.189		0.197
E	3.80		4.00	0.150		0.157
e		1.27			0.050	
H	5.80		6.20	0.228		0.244
h	0.25		0.50	0.010		0.020
L	0.40		1.27	0.016		0.050
k	8° (max.)					
ddd			0.1			0.04

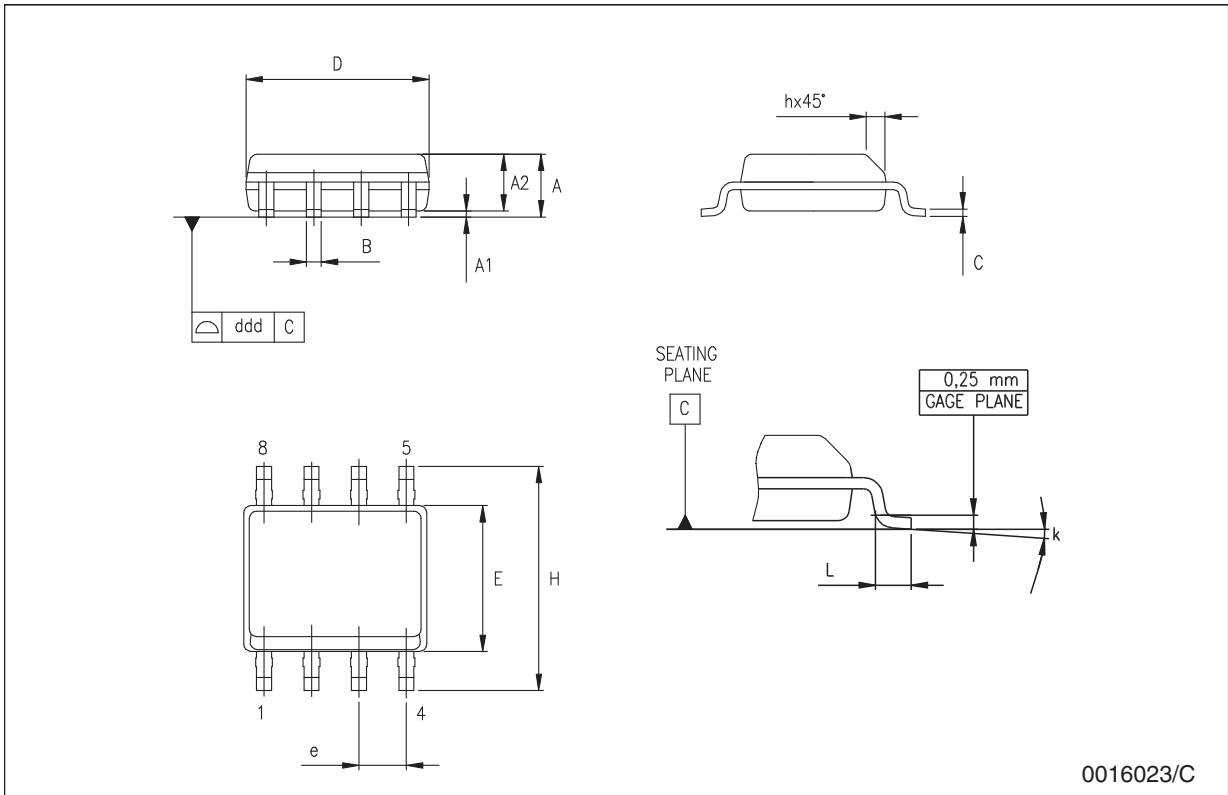

Tape & reel DPAK-PPAK mechanical data

Dim.	mm.			inch.		
	Min.	Typ.	Max.	Min.	Typ.	Max.
A			330			12.992
C	12.8	13.0	13.2	0.504	0.512	0.519
D	20.2			0.795		
N	60			2.362		
T			22.4			0.882
Ao	6.80	6.90	7.00	0.268	0.272	0.276
Bo	10.40	10.50	10.60	0.409	0.413	0.417
Ko	2.55	2.65	2.75	0.100	0.104	0.105
Po	3.9	4.0	4.1	0.153	0.157	0.161
P	7.9	8.0	8.1	0.311	0.315	0.319

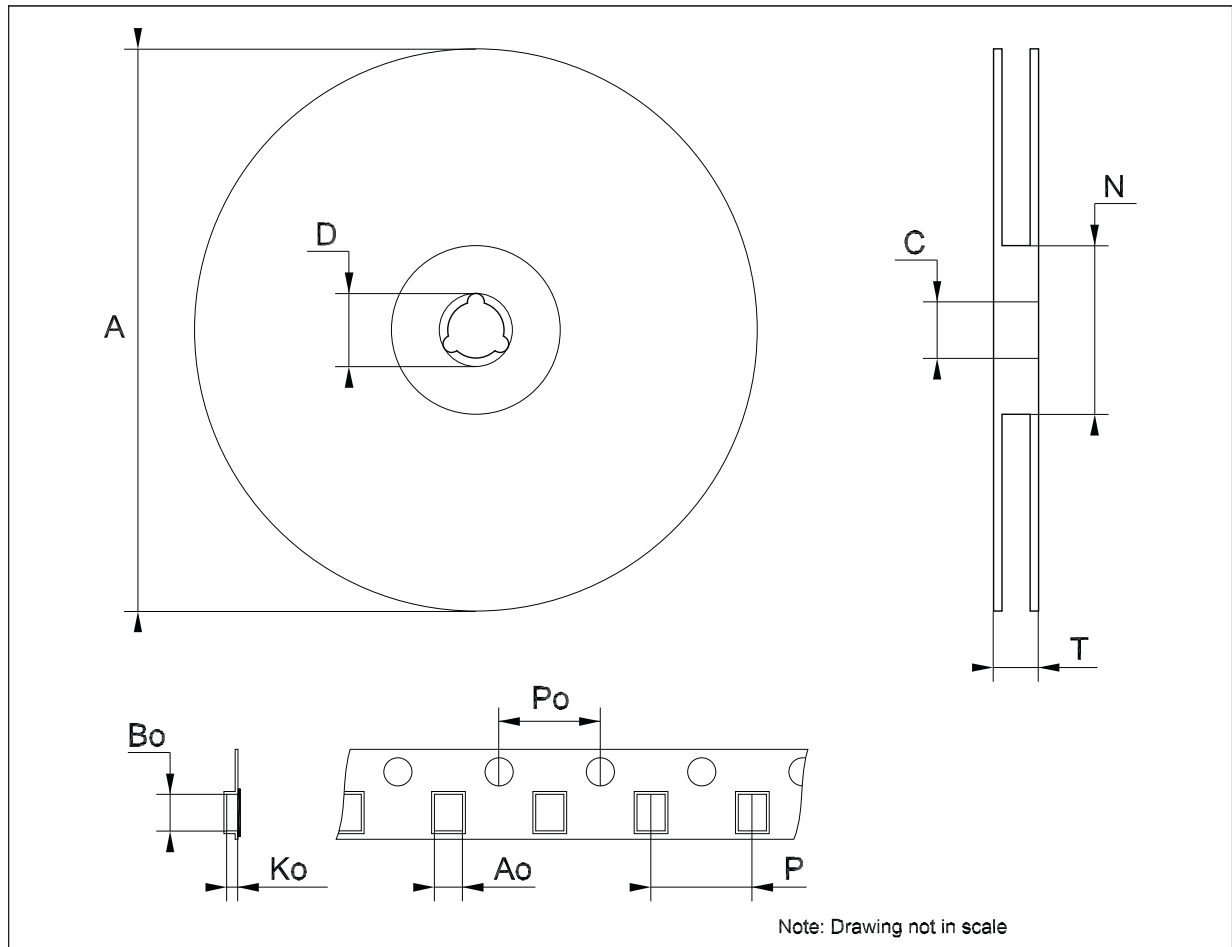

Tape & reel SO-8 mechanical data

Dim.	mm.			inch.		
	Min.	Typ.	Max.	Min.	Typ.	Max.
A			330			12.992
C	12.8		13.2	0.504		0.519
D	20.2			0.795		
N	60			2.362		
T			22.4			0.882
Ao	8.1		8.5	0.319		0.335
Bo	5.5		5.9	0.216		0.232
Ko	2.1		2.3	0.082		0.090
Po	3.9		4.1	0.153		0.161
P	7.9		8.1	0.311		0.319

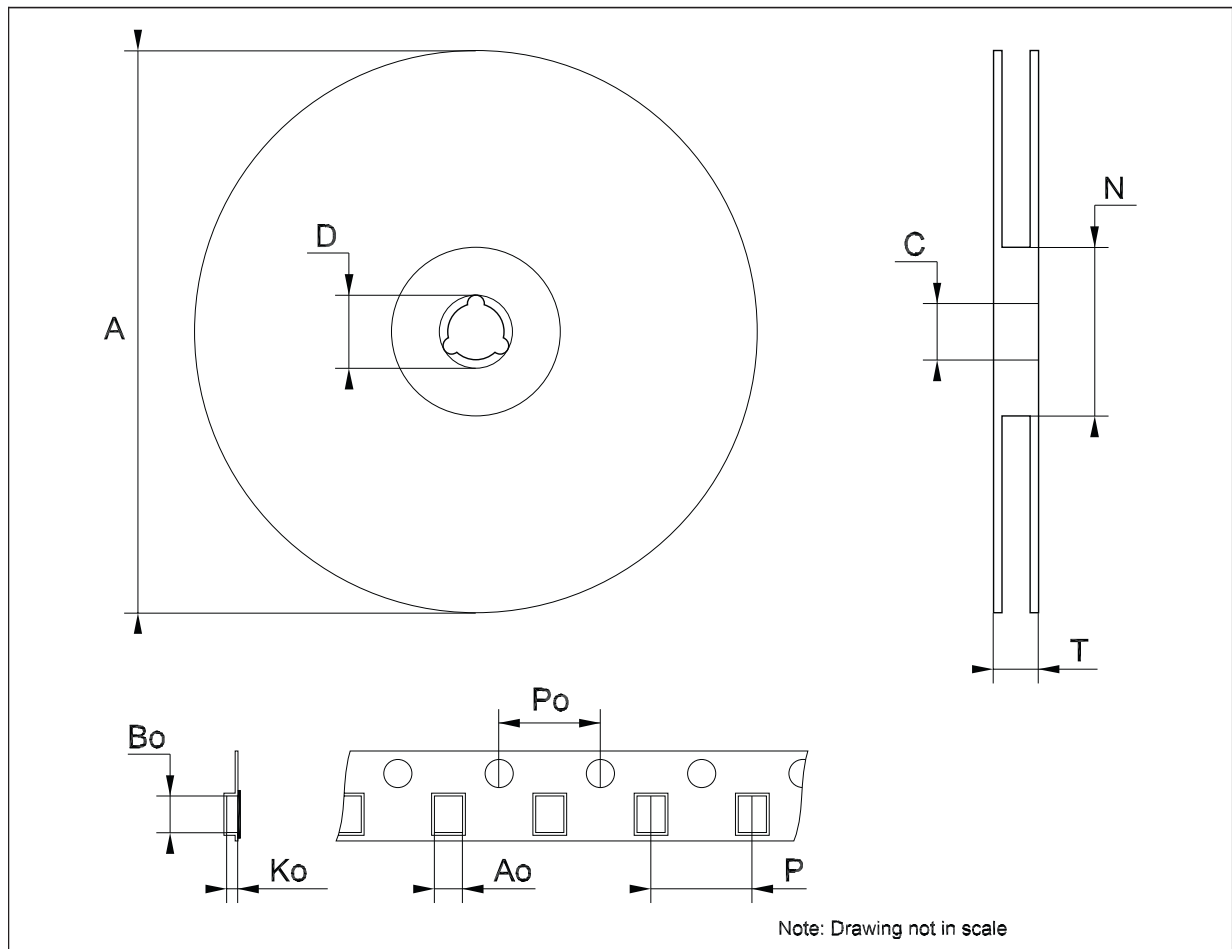

Tape & reel for TO-92 mechanical data

Dim.	mm.			inch.		
	Min.	Typ.	Max.	Min.	Typ.	Max.
A1		4.80			0.189	
T		3.80			0.150	
T1		1.60			0.063	
T2		2.30			0.091	
d		0.48			0.019	
P0	12.5		12.9	0.492		0.508
P2	5.65		7.05	0.222		0.278
F1, F2	2.44	2.54	2.94	0.096	0.100	0.116
delta H		±2			0.079	
W	17.5	18.00	19.0	0.689	0.709	0.748
W0	5.7		6.3	0.224		0.248
W1	8.5		9.25	0.335		0.364
W2		0.50			0.20	
H		18.50	18.70		0.728	0.726
H0	15.50		16.50	0.610		0.650
H1		25.00			0.984	
D0	3.8		4.2	0.150		0.165
t		0.90			0.035	
L1		3			0.118	
delta P		±1			0.039	
u		50			1.968	
Φ1		360			14.173	
Φ2		30			1.181	

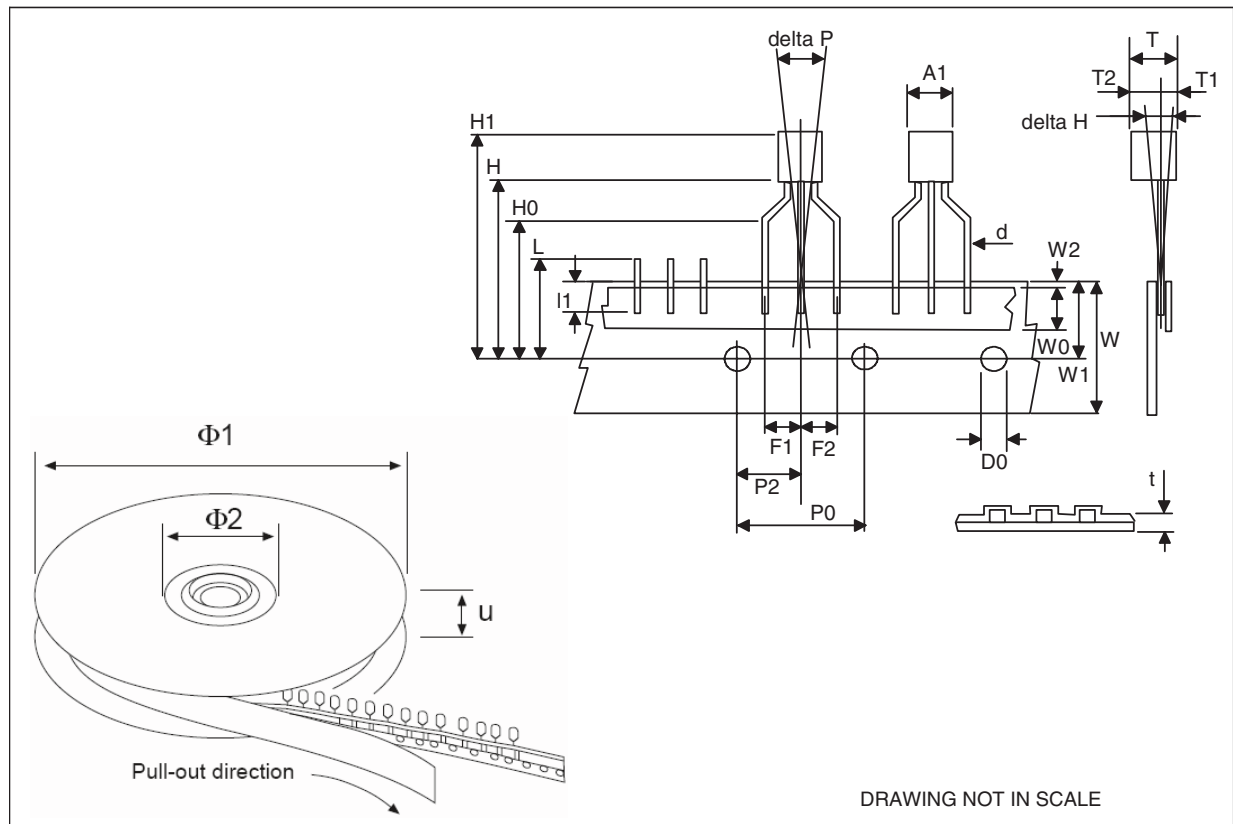

8 Order codes

Table 24. Order codes

Packages					
TO-220	SO-8	PPAK	DPAK	TO-92	Output voltage
	L4931CD15-TR				1.5 V
	L4931ABD15-TR				1.5 V
	L4931CD25-TR	L4931CPT25-TR	L4931CDT25-TR		2.5 V
	L4931ABD25-TR	L4931ABPT25TR	L4931ABDT25-TR		2.5 V
	L4931CD27-TR	L4931CPT27-TR	L4931CDT27-TR		2.7 V
	L4931CD27-TRY ⁽¹⁾	L4931ABPT27TR			2.7 V
L4931CV33	L4931CD33-TR	L4931CPT33-TR	L4931CDT33-TR	L4931CZ33-AP	3.3 V
L4931ABV33	L4931ABD33-TR	L4931ABPT33TR	L4931ABDT33-TR		3.3 V
	L4931CD33-TRY ⁽¹⁾				3.3 V
L4931CV35	L4931CD35-TR	L4931CPT35-TR	L4931CDT35-TR	L4931CZ35-AP	3.5 V
L4931ABV35	L4931ABD35-TR	L4931ABPT35TR	L4931ABDT35-TR	L4931ABZ35-AP	3.5 V
	L4931ABD35-TRY ⁽¹⁾				3.5 V
			L4931CDT47-TR		4.75 V
L4931CV50	L4931CD50-TR	L4931CPT50-TR	L4931CDT50-TR	L4931CZ50-AP	5 V
L4931ABV50	L4931ABD50-TR	L4931ABPT50TR	L4931ABDT50-TR	L4931ABZ50-AP	5 V
	L4931CD80-TR	L4931CPT80-TR	L4931CDT80-TR		8 V
	L4931ABD80-TR	L4931ABPT80TR	L4931ABDT80-TR		8 V
L4931CV120	L4931CD120-TR	L4931CPT120-TR	L4931CDT120-TR		12 V
L4931ABV120	L4931ABD120-TR	L4931ABPT120R			12 V

1. Automotive Grade products.

9 Revision history

Table 25. Document revision history

Date	Revision	Changes
21-Jun-2004	11	Document updating.
14-Jun-2006	12	Order codes updated.
31-Jan-2008	13	Added: Table 1 and new order codes for Automotive grade products.

Please Read Carefully:

Information in this document is provided solely in connection with ST products. STMicroelectronics NV and its subsidiaries ("ST") reserve the right to make changes, corrections, modifications or improvements, to this document, and the products and services described herein at any time, without notice.

All ST products are sold pursuant to ST's terms and conditions of sale.

Purchasers are solely responsible for the choice, selection and use of the ST products and services described herein, and ST assumes no liability whatsoever relating to the choice, selection or use of the ST products and services described herein.

No license, express or implied, by estoppel or otherwise, to any intellectual property rights is granted under this document. If any part of this document refers to any third party products or services it shall not be deemed a license grant by ST for the use of such third party products or services, or any intellectual property contained therein or considered as a warranty covering the use in any manner whatsoever of such third party products or services or any intellectual property contained therein.

UNLESS OTHERWISE SET FORTH IN ST'S TERMS AND CONDITIONS OF SALE ST DISCLAIMS ANY EXPRESS OR IMPLIED WARRANTY WITH RESPECT TO THE USE AND/OR SALE OF ST PRODUCTS INCLUDING WITHOUT LIMITATION IMPLIED WARRANTIES OF MERCHANTABILITY, FITNESS FOR A PARTICULAR PURPOSE (AND THEIR EQUIVALENTS UNDER THE LAWS OF ANY JURISDICTION), OR INFRINGEMENT OF ANY PATENT, COPYRIGHT OR OTHER INTELLECTUAL PROPERTY RIGHT.

UNLESS EXPRESSLY APPROVED IN WRITING BY AN AUTHORIZED ST REPRESENTATIVE, ST PRODUCTS ARE NOT RECOMMENDED, AUTHORIZED OR WARRANTED FOR USE IN MILITARY, AIR CRAFT, SPACE, LIFE SAVING, OR LIFE SUSTAINING APPLICATIONS, NOR IN PRODUCTS OR SYSTEMS WHERE FAILURE OR MALFUNCTION MAY RESULT IN PERSONAL INJURY, DEATH, OR SEVERE PROPERTY OR ENVIRONMENTAL DAMAGE. ST PRODUCTS WHICH ARE NOT SPECIFIED AS "AUTOMOTIVE GRADE" MAY ONLY BE USED IN AUTOMOTIVE APPLICATIONS AT USER'S OWN RISK.

Resale of ST products with provisions different from the statements and/or technical features set forth in this document shall immediately void any warranty granted by ST for the ST product or service described herein and shall not create or extend in any manner whatsoever, any liability of ST.

ST and the ST logo are trademarks or registered trademarks of ST in various countries.

Information in this document supersedes and replaces all information previously supplied.

The ST logo is a registered trademark of STMicroelectronics. All other names are the property of their respective owners.

© 2008 STMicroelectronics - All rights reserved

STMicroelectronics group of companies

Australia - Belgium - Brazil - Canada - China - Czech Republic - Finland - France - Germany - Hong Kong - India - Israel - Italy - Japan - Malaysia - Malta - Morocco - Singapore - Spain - Sweden - Switzerland - United Kingdom - United States of America

www.st.com