

FEATURES

- Operates with 3.3 V supply
- ESD protection: 8 kV meets IEC1000-4-2
- EFT protection: 2 kV meets IEC1000-4-4
- EIA RS-422 and RS-485 compliant over full CM range
- 19 k Ω input impedance
- Up to 50 transceivers on bus
- 20 Mbps data rate
- Short-circuit protection
- Specified over full temperature range
- Thermal shutdown
- Interoperable with 5 V logic
- 1 mA supply current
- 2 nA shutdown current
- 8 ns skew

APPLICATIONS

- Telecommunications
- DTE-DCE interfaces
- Packet switching
- Local area networks
- Data concentration
- Data multiplexers
- Integrated services digital network (ISDN)
- AppleTalk
- Industrial controls

GENERAL DESCRIPTION

The ADM3485E is a low power, differential line transceiver that operates with a single 3.3 V power supply. Low power consumption makes it ideal for power-sensitive applications.

It is suitable for communication on multipoint bus transmission lines. Internal protection against electrostatic discharge (ESD) and electrical fast transient (EFT) allows operation in electrically harsh environments.

It is intended for balanced data transmission and complies with both EIA Standards RS-485 and RS-422. It contains a differential line driver and a differential line receiver, and is suitable for half-duplex data transfer.

The input impedance is 19 k Ω following up to 50 transceivers to be connected on the bus.

Rev. B

Information furnished by Analog Devices is believed to be accurate and reliable. However, no responsibility is assumed by Analog Devices for its use, nor for any infringements of patents or other rights of third parties that may result from its use. Specifications subject to change without notice. No license is granted by implication or otherwise under any patent or patent rights of Analog Devices. Trademarks and registered trademarks are the property of their respective owners.

FUNCTIONAL BLOCK DIAGRAM

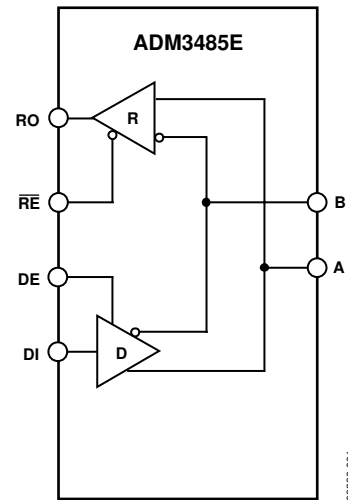

Figure 1.

Excessive power dissipation caused by bus contention or by output shorting is prevented by a thermal shutdown circuit. This feature forces the driver output into a high impedance state if, during fault conditions, a significant temperature increase is detected in the internal driver circuitry.

The receiver contains a fail-safe feature that results in a logic high output state if the inputs are unconnected (floating).

The device is fabricated on BiCMOS, an advanced mixed technology process combining low power CMOS with fast switching bipolar technology.

The ADM3485E is fully specified over the industrial temperature range and is available in 8-lead PDIP and SOIC packages.

TABLE OF CONTENTS

Specifications.....	3	ESD/EFT Transient Protection Scheme	11
Timing Specifications.....	4	ESD Testing	11
Absolute Maximum Ratings.....	5	Fast Transient Burst Immunity (IEC1000-4-4)	12
ESD Caution.....	5	Applications Information	13
Pin Configurations and Pin Function Descriptions	6	Differential Data Transmission	13
Test Circuits.....	7	Cable and Data Rate.....	13
Switching Characteristics	8	Receiver Open-Circuit Fail-Safe.....	13
Typical Performance Characteristics	9	Outline Dimensions	14
Standards and Testing	11	Ordering Guide	14

REVISION HISTORY

10/04—Data Sheet Changed from Rev. A to Rev. B

Updated Format.....	Universal
Changes to Power-Supply Current, Table 1	3
Updated Outline Dimensions	14
Changes to Ordering Guide	14

5/00—Data Sheet Changed from Rev. 0 to Rev. A

SPECIFICATIONS

$V_{CC} = +3.3\text{ V} \pm 0.3\text{ V}$. All specifications T_{MIN} to T_{MAX} , unless otherwise noted.

Table 1.

Parameter	Min	Typ	Max	Unit	Test Conditions/Comments
DRIVER					
Differential Output Voltage, V_{OD}	2.0			V	$R_L = 100\ \Omega$, $V_{CC} > 3.1\text{ V}$; see Figure 3
	1.5			V	$R_L = 54\ \Omega$; see Figure 9
	1.5			V	$R_L = 60\ \Omega$, see Figure 4; $-7\text{ V} < V_{TST} < +12\text{ V}$
$\Delta V_{OD} $ for Complementary Output States			0.2	V	$R = 54\ \Omega$ or $100\ \Omega$; see Figure 3
Common-Mode Output Voltage V_{OC}			3	V	$R = 54\ \Omega$ or $100\ \Omega$; see Figure 3
$\Delta V_{OC} $ for Complementary Output States			0.2	V	$R = 54\ \Omega$ or $100\ \Omega$; see Figure 3
CMOS Input Logic Threshold Low, V_{INL}			0.8	V	
CMOS Input Logic Threshold High, V_{INH}	2.0			V	
Logic Input Current (DE, DI, \overline{RE})			± 1.0	μA	
Output Short-Circuit Current			± 250	mA	$V_O = -7\text{ V}$ or $+12\text{ V}$
RECEIVER					
Differential Input Threshold Voltage, V_{TH}	-0.2		+0.2	V	$-7\text{ V} < V_{CM} < +12\text{ V}$
Input Voltage Hysteresis, ΔV_{TH}		50		mV	$V_{CM} = 0\text{ V}$
Input Resistance	12	19		k Ω	$-7\text{ V} < V_{CM} < +12\text{ V}$
Input Current (A, B)			1	mA	$V_{IN} = 12\text{ V}$
			-0.8	mA	$V_{IN} = -7\text{ V}$
Logic Enable Input Current (\overline{RE})			± 1	μA	
Output Voltage Low, V_{OL}			0.4	V	$I_{OUT} = +2.5\text{ mA}$
Output Voltage High, V_{OH}	$V_{CC} - 0.4\text{ V}$			V	$I_{OUT} = -1.5\text{ mA}$
Short-Circuit Output Current			± 60	mA	$V_{OUT} = \text{GND}$ or V_{CC}
Three-State Output Leakage Current			± 1.0	μA	$V_{CC} = 3.6\text{ V}$, $0\text{ V} < V_{OUT} < V_{CC}$
POWER-SUPPLY CURRENT					
I_{CC}					Outputs unloaded
		1	1.5	mA	$DE = V_{CC}$, $\overline{RE} = 0\text{ V}$
		1	1.5	mA	$DE = 0\text{ V}$, $\overline{RE} = 0\text{ V}$
Supply Current in Shutdown		0.002	1	μA	$DE = 0\text{ V}$, $\overline{RE} = V_{CC}$
ESD/EFT IMMUNITY					
ESD Protection		± 8		kV	IEC1000-4-2 A, B pins contact discharge
EFT Protection		± 2		kV	IEC1000-4-4, A, B pins

ADM3485E

TIMING SPECIFICATIONS

$V_{CC} = 3.3\text{ V}$, $T_A = 25^\circ\text{C}$, unless otherwise noted.

Table 2.

Parameter	Min	Typ	Max	Unit	Test Conditions/Comments
DRIVER					
Differential Output Delay T_{DD}	1		35	ns	$R_L = 60\ \Omega$, $C_{L1} = C_{L2} = 15\ \text{pF}$; see Figure 5
Differential Output Transition Time	1	8	15	ns	$R_L = 60\ \Omega$, $C_{L1} = C_{L2} = 15\ \text{pF}$; see Figure 5
Propagation Delay Input to Output T_{PLH} , T_{PHL}	7	22	35	ns	$R_L = 27\ \Omega$, $C_{L1} = C_{L2} = 15\ \text{pF}$; see Figure 9
Driver Output-to-Output T_{SKEW}			8	ns	$R_L = 54\ \Omega$, $C_{L1} = C_{L2} = 15\ \text{pF}$; see Figure 5
ENABLE/DISABLE					
Driver Enable to Output Valid		45	90	ns	$R_L = 110\ \Omega$, $C_L = 50\ \text{pF}$; see Figure 4
Driver Disable Timing		40	80	ns	$R_L = 110\ \Omega$, $C_L = 50\ \text{pF}$; see Figure 4
Driver Enable from Shutdown		650	110	ns	$R_L = 110\ \Omega$, $C_L = 15\ \text{pF}$; see Figure 4
RECEIVER					
Time to Shutdown	80	190	300	ns	
Propagation Delay Input to Output T_{PLH} , T_{PHL}	25	65	90	ns	$C_L = 15\ \text{pF}$; see Figure 10
Skew $T_{PLH} - T_{PHL}$			10	ns	$C_L = 15\ \text{pF}$; see Figure 10
Receiver Enable T_{EN}		25	50	ns	$C_L = 15\ \text{pF}$; see Figure 8
Receiver Disable T_{DEN}		25	45	ns	$C_L = 15\ \text{pF}$; see Figure 8
Receiver Enable from Shutdown			500	ns	$C_L = 15\ \text{pF}$; see Figure 8

TIMING SPECIFICATIONS

$V_{CC} = 3.3\text{ V} \pm 0.3\text{ V}$, $T_A = T_{MIN}$ to T_{MAX} , unless otherwise noted.

Table 3.

Parameter	Min	Typ	Max	Unit	Test Conditions/Comments
DRIVER					
Differential Output Delay T_{DD}	1		70	ns	$R_L = 60\ \Omega$, $C_{L1} = C_{L2} = 15\ \text{pF}$; see Figure 5
Differential Output Transition Time	2	8	15	ns	$R_L = 60\ \Omega$, $C_{L1} = C_{L2} = 15\ \text{pF}$; see Figure 5
Propagation Delay Input to Output T_{PLH} , T_{PHL}	7	22	70	ns	$R_L = 27\ \Omega$, $C_{L1} = C_{L2} = 15\ \text{pF}$; see Figure 9
Driver Output-to-Output T_{SKEW}			10	ns	$R_L = 54\ \Omega$, $C_{L1} = C_{L2} = 15\ \text{pF}$; see Figure 5
ENABLE/DISABLE					
Driver Enable to Output Valid		45	110	ns	$R_L = 110\ \Omega$, $C_L = 50\ \text{pF}$; see Figure 4
Driver Disable Timing		40	110	ns	$R_L = 110\ \Omega$, $C_L = 50\ \text{pF}$; see Figure 4
Driver Enable from Shutdown		650	110	ns	$R_L = 110\ \Omega$, $C_L = 15\ \text{pF}$; see Figure 4
RECEIVER					
Time to Shutdown	50	190	500	ns	
Propagation Delay Input to Output T_{PLH} , T_{PHL}	25	65	115	ns	$C_L = 15\ \text{pF}$, Figure 10
Skew $T_{PLH} - T_{PHL}$			20	ns	$C_L = 15\ \text{pF}$, Figure 10
Receiver Enable T_{EN}		25	50	ns	$C_L = 15\ \text{pF}$, Figure 8
Receiver Disable T_{DEN}		25	50	ns	$C_L = 15\ \text{pF}$, Figure 8
Receiver Enable from Shutdown			600	ns	$C_L = 15\ \text{pF}$, Figure 8

ABSOLUTE MAXIMUM RATINGS

$T_A = +25^\circ\text{C}$, unless otherwise noted.

Table 4.

Parameter	Values
V_{CC}	7 V
Inputs	
Driver Input (DI)	$-0.3\text{ V to }V_{CC} + 0.3\text{ V}$
Control Inputs (DE, $\overline{\text{RE}}$)	$-0.3\text{ V to }V_{CC} + 0.3\text{ V}$
Receiver Inputs (A, B)	$-7.5\text{ V to }+12.5\text{ V}$
Outputs	
Driver Outputs	$-7.5\text{ V to }+12.5\text{ V}$
Receiver Output	$-0.5\text{ V to }V_{CC} + 0.5\text{ V}$
Power Dissipation 8-Lead PDIP	800 mW
θ_{JA} , Thermal Impedance	140°C/W
Power Dissipation 8-Lead SOIC	650 mW
θ_{JA} , Thermal Impedance	115°C/W
Operating Temperature Range	
Industrial (A Version)	$-40^\circ\text{C to }+85^\circ\text{C}$
Storage Temperature Range	$-65^\circ\text{C to }+150^\circ\text{C}$
Lead Temperature (Soldering, 10 sec)	300°C
Vapor Phase (60 sec)	215°C
Infrared (15 sec)	220°C
ESD Rating: Air (Human Body Model, All Pins)	$> 4\text{ kV}$
ESD Rating: IEC1000-4-2 Contact (A, B Pins)	$> 8\text{ kV}$
EFT Rating: IEC1000-4-4 (A, B Pins)	$> 2\text{ kV}$

Stresses above those listed under Absolute Maximum Ratings may cause permanent damage to the device. This is a stress rating only; functional operation of the device at these or any other conditions above those listed in the operational sections of this specification is not implied. Exposure to absolute maximum ratings for extended periods of time may affect device reliability.

ESD CAUTION

ESD (electrostatic discharge) sensitive device. Electrostatic charges as high as 4000 V readily accumulate on the human body and test equipment and can discharge without detection. Although this product features proprietary ESD protection circuitry, permanent damage may occur on devices subjected to high energy electrostatic discharges. Therefore, proper ESD precautions are recommended to avoid performance degradation or loss of functionality.



ADM3485E

PIN CONFIGURATIONS AND PIN FUNCTION DESCRIPTIONS

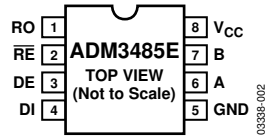

Figure 2. PDIP/SOIC Pin Configuration

Table 5. Pin Function Descriptions

Mnemonic	DIP/SOIC	Description
RO	1	Receiver Output. High when $A > B$ by 200 mV or low when $A < B$ by 200 mV.
\overline{RE}	2	Receiver Output Enable. With \overline{RE} low, the receiver output RO is enabled. With \overline{RE} high, the output goes high impedance. If \overline{RE} is high and DE low, the ADM3485E enters a shutdown state.
DE	3	Driver Output Enable. A high level enables the driver differential outputs A and B. A low level places it in a high impedance state.
DI	4	Driver Input. When the driver is enabled, a logic low on DI forces A low and B high, while a logic high on DI forces A high and B low.
GND	5	Ground Connection, 0 V.
A	6	Noninverting Receiver Input A/Driver Output A.
B	7	Inverting Receiver Input B/Driver Output B.
V _{CC}	8	Power Supply, 3.3 V \pm 0.3 V.

TEST CIRCUITS

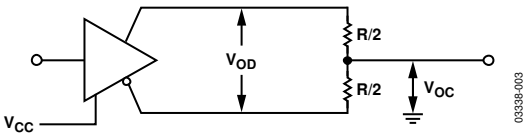

Figure 3. Driver Voltage Measurement Test Circuit

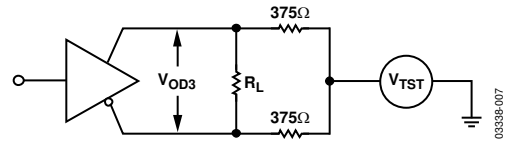

Figure 7. Driver Voltage Measurement Test Circuit 2

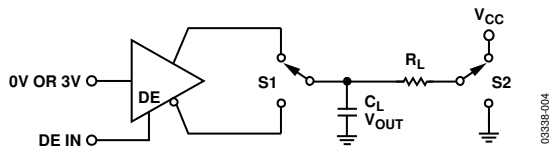

Figure 4. Driver Enable/Disable Test Circuit

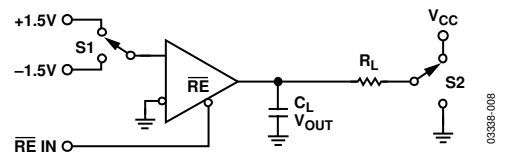

Figure 8. Receiver Enable/Disable Test Circuit

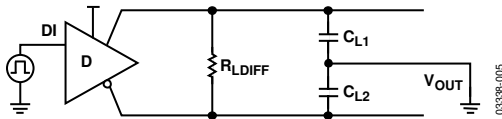

Figure 5. Driver Differential Output Delay Test Circuit

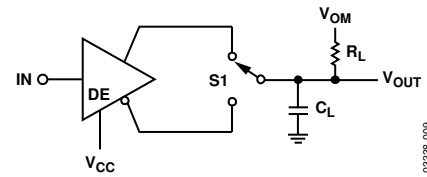

Figure 9. Driver Propagation Delay Test Circuit

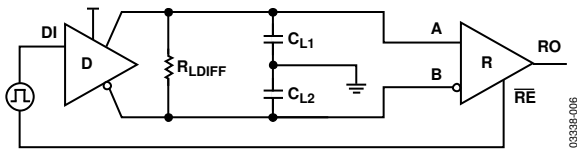

Figure 6. Driver/Receiver Propagation Delay Test Circuit

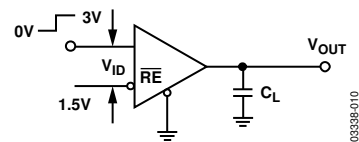

Figure 10. Receiver Propagation Delay Test Circuit

SWITCHING CHARACTERISTICS

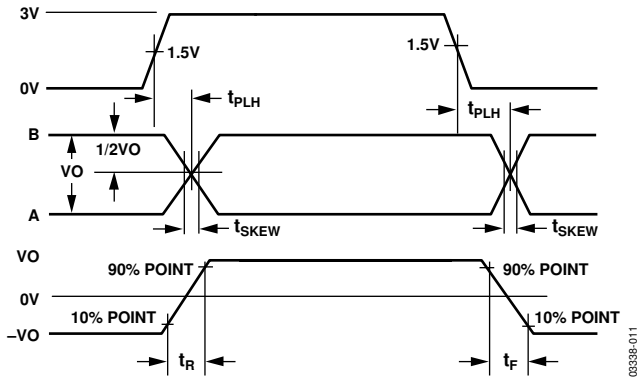

Figure 11. Driver Propagation Delay, Rise/Fall Timing

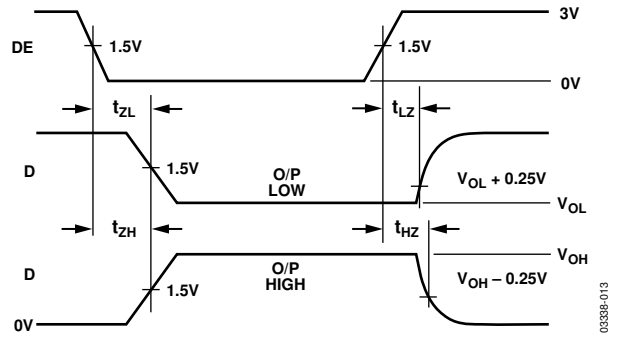

Figure 13. Driver Enable/Disable Timing

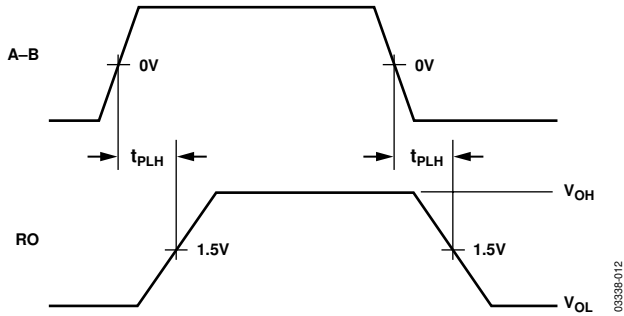

Figure 12. Receiver Propagation Delay

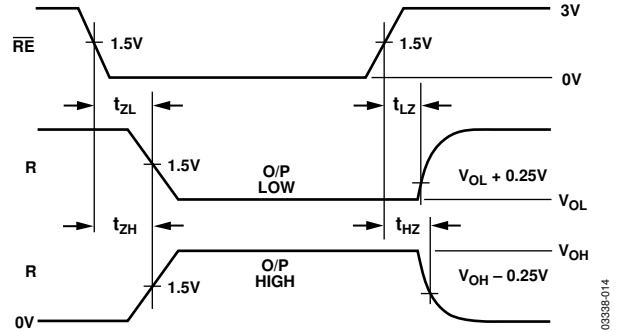

Figure 14. Receiver Enable/Disable Timing

TYPICAL PERFORMANCE CHARACTERISTICS

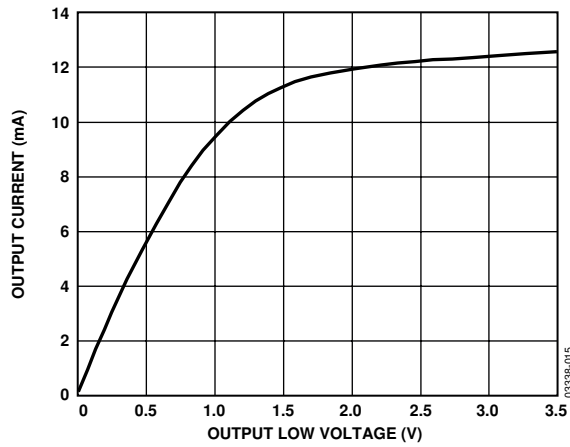

Figure 15. Output Current vs. Receiver Output Low Voltage

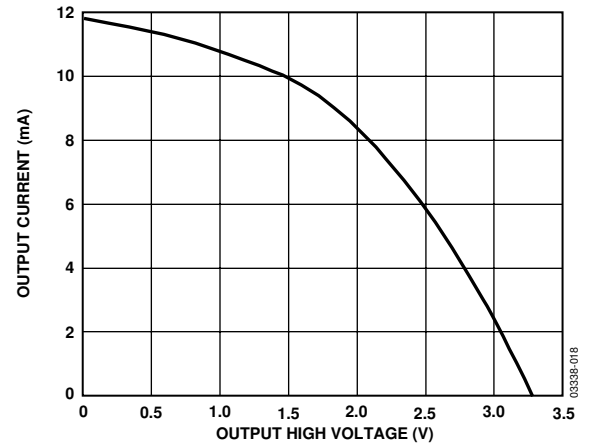

Figure 18. Output Current vs. Receiver Output High Voltage

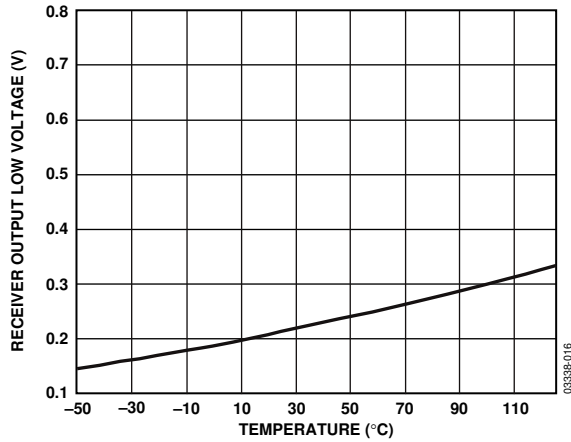

Figure 16. Receiver Output Low Voltage vs. Temperature

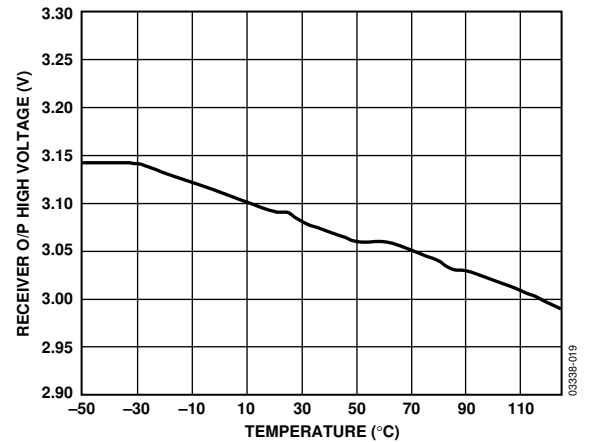

Figure 19. Receiver Output High Voltage vs. Temperature

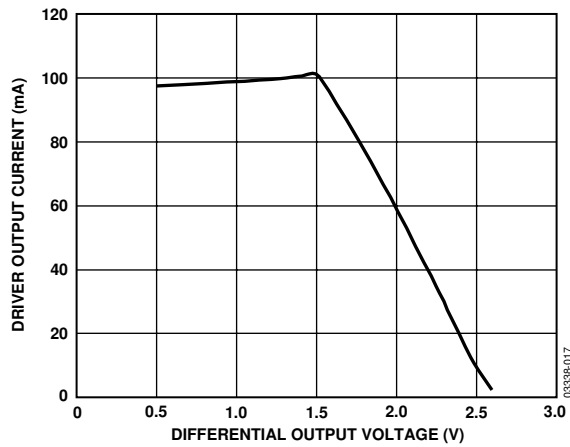

Figure 17. Driver Output Current vs. Differential Output Voltage

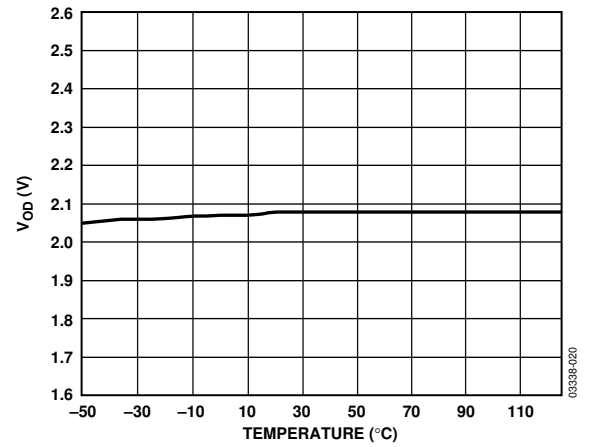

Figure 20. Driver Differential Output Voltage vs. Temperature

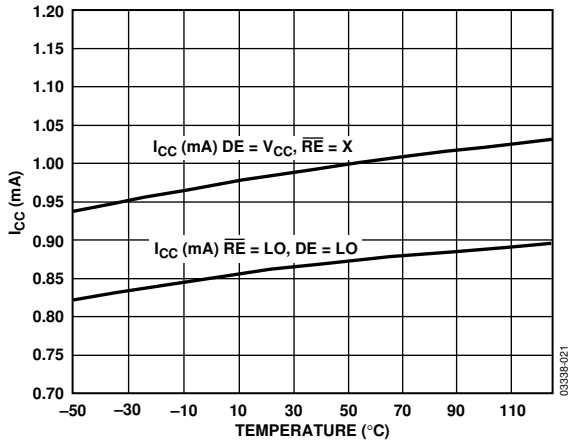

Figure 21. Supply Current vs. Temperature

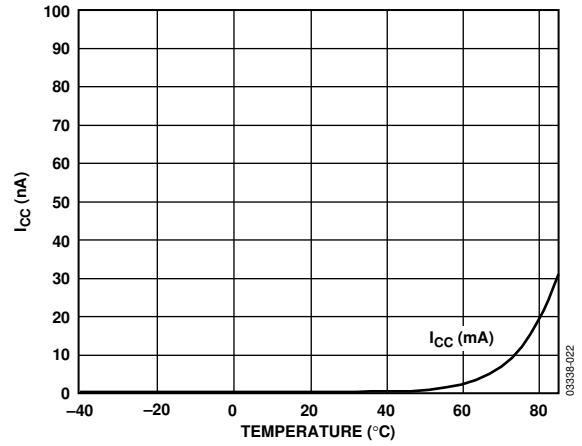

Figure 22. Shutdown Current vs. Temperature

STANDARDS AND TESTING

Table 6 compares RS-422 and RS-485 interface standards, while Table 7 and Table 8 show transmitting and receiving truth tables.

Table 6.

Specification	RS-422	RS-485
Transmission Type	Differential	Differential
Maximum Data Rate	10 MB/s	10 MB/s
Maximum Cable Length	4000 ft.	4000 ft.
Minimum Driver Output Voltage	±2 V	±1.5 V
Driver Load Impedance	100 Ω	54 Ω
Receiver Input Resistance	4 kΩ min	12 kΩ min
Receiver Input Sensitivity	±200 mV	±200 mV
Receiver Input Voltage Range	-7 V to +7 V	-7 V to +12 V
No. of Drivers/Receivers Per Line	1/10	32/32

Table 7. Transmitting Truth Table

Transmitting Inputs			Transmitting Outputs	
RE	DE	DI	B	A
X	1	1	0	1
X	1	0	1	0
0	0	X	Hi-Z	Hi-Z
1	0	X	Hi-Z	Hi-Z

Table 8. Receiving Truth Table

Receiving Inputs		Receiving Outputs	
RE	DE	A-B	RO
0	X	> +0.2 V	1
0	X	< -0.2 V	0
0	X	Inputs O/C	1
1	X	X	Hi-Z

ESD/EFT TRANSIENT PROTECTION SCHEME

The ADM3485E uses protective clamping structures on its inputs and outputs that clamp the voltage to a safe level and dissipate the energy present in ESD (electrostatic) and EFT (electrical fast transients) discharges. This protection structure achieves ESD protection up to 8 kV according to IEC1000-4-2, and EFT protection up to 2 kV on all input/output (I/O) lines.

ESD TESTING

Two coupling methods are used for ESD testing, contact discharge and air-gap discharge. Contact discharge calls for a direct connection to the unit being tested. Air-gap discharge uses a higher test voltage but does not make direct contact with the unit under test. With air discharge, the discharge gun is moved toward the unit under test, developing an arc across the air gap, hence the term air-discharge. This method is influenced by humidity, temperature, barometric pressure, distance, and rate of closure of the discharge gun. The contact-discharge method, while less realistic, is more repeatable and is gaining acceptance and preference over the air-gap method.

Although very little energy is contained within an ESD pulse, the extremely fast rise time, coupled with high voltages, can cause failures in unprotected semiconductors. Catastrophic destruction can occur immediately as a result of arcing or heating. Even if catastrophic failure does not occur immediately, the device may suffer from parametric degradation, which may result in degraded performance. The cumulative effects of continuous exposure can eventually lead to complete failure.

I/O lines are particularly vulnerable to ESD damage. Simply touching or plugging in an I/O cable can result in a static discharge that can damage or completely destroy the interface product connected to the I/O port. It is extremely important, therefore, to have high levels of ESD protection on the I/O lines.

The ESD discharge could induce latch-up in the device under test, so it is important that ESD testing on the I/O pins be carried out while device power is applied. This type of testing is more representative of a real-world I/O discharge where the equipment is operating normally when the discharge occurs.

Table 9. ESD Test Results

ESD Test Method	I/O Pins
IEC1000-4-2: Contact	±8 kV

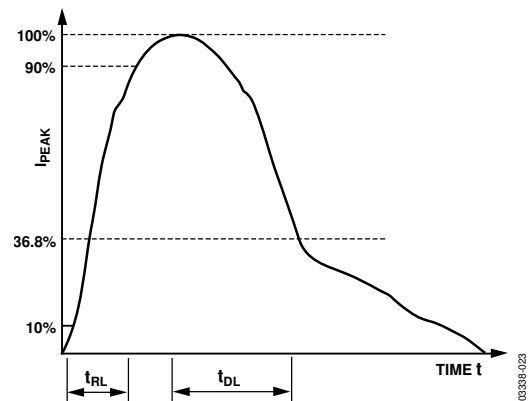

Figure 23. Human Body Model Current Waveform

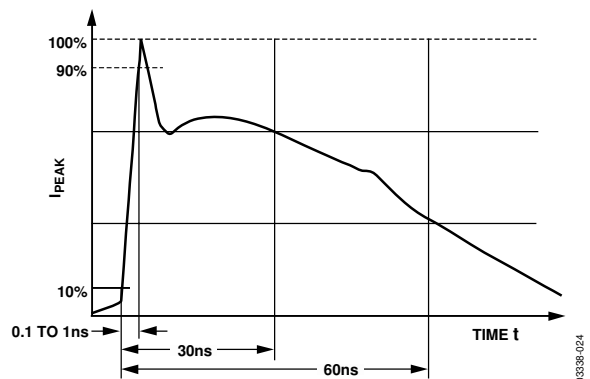

Figure 24. IEC1000-4-2 ESD Current Waveform

FAST TRANSIENT BURST IMMUNITY (IEC1000-4-4)

IEC1000-4-4 (previously 801-4) covers electrical fast-transient-burst (EFT) immunity. Electrical fast transients occur as a result of arcing contacts in switches and relays. The tests simulate the interference generated when, for example, a power relay disconnects an inductive load. A spark is generated due to the well-known back EMF effect. This spark consists of a burst of sparks as the relay contacts separate. The voltage appearing on the line consists of a burst of extremely fast transient impulses. A similar effect occurs when turning on fluorescent lights.

The fast transient burst test, defined in IEC1000-4-4, simulates this arcing and its waveform is illustrated in Figure 25. It consists of a burst of 2.5 kHz to 5 kHz transients repeating at 300 ms intervals. It is specified for both power and data lines.

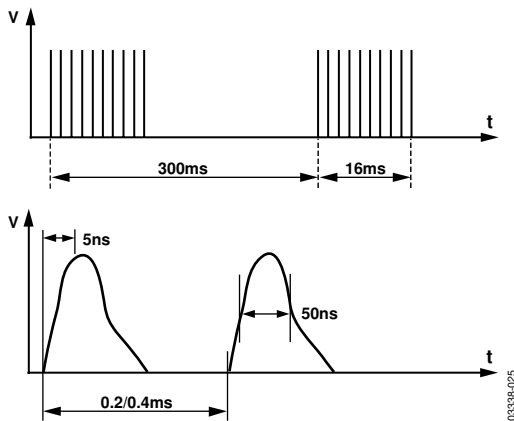

Figure 25. IEC1000-4-4 Fast Transient Waveform

Four severity levels are defined in terms of an open-circuit voltage as a function of the installation environment. The installation environments are defined as

- Well-Protected
- Protected
- Typical Industrial
- Severe Industrial

Table 10 shows the peak voltages for each of the environments.

Table 10. Peak Voltages

Level	V_{PEAK} (kV) PSU	V_{PEAK} (kV) I/O
Well-Protected	0.5	0.25
Protected	1	0.5
Typical Industrial	2	1
Severe Industrial	4	2

A simplified circuit diagram of the actual EFT generator is illustrated in Figure 26.

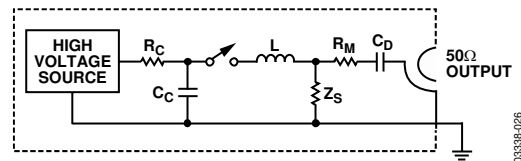

Figure 26. EFT Generator

These transients are coupled onto the signal lines using an EFT coupling clamp. The clamp is 1 m long and completely surrounds the cable, providing maximum coupling capacitance (50 pF to 200 pF, typ) between the clamp and the cable. High energy transients are capacitively coupled onto the signal lines. Fast rise times (5 ns), as specified by the standard, result in very effective coupling. This test is severe because high voltages are coupled onto the signal lines. The repetitive transients can cause problems, where single pulses do not. Destructive latch-up may be induced due to the high energy content of the transients. Note that this stress is applied while the interface products are powered up and are transmitting data. The EFT test applies hundreds of pulses with higher energy than ESD. The worst-case transient current on an I/O line can be as high as 40 A.

Test results are classified according to the following:

- Normal performance within specification limits.
- Temporary degradation or loss of performance that is self-recoverable.
- Temporary degradation or loss of function or performance that requires operator intervention or system reset.
- Degradation or loss of function that is not recoverable due to damage.

APPLICATIONS INFORMATION

DIFFERENTIAL DATA TRANSMISSION

Differential data transmission is used to reliably transmit data at high rates over long distances and through noisy environments. Differential transmission nullifies the effects of ground shifts and noise signals that appear as common-mode voltages on the line.

Two main standards are approved by the Electronics Industries Association (EIA) which specify the electrical characteristics of transceivers used in differential data transmission. The RS-422 standard specifies data rates up to 10 MBaud and line lengths up to 4000 feet. A single driver can drive a transmission line with up to 10 receivers.

The RS-485 standard was defined to cater to true multipoint communications. This standard meets or exceeds all the requirements of RS-422, but also allows multiple drivers and receivers to be connected to a single bus. An extended common-mode range of -7 V to $+12\text{ V}$ is defined.

The most significant difference between RS-422 and RS-485 is the fact that the drivers may be disabled, thereby allowing more than one to be connected to a single line. Only one driver should be enabled at a time, but the RS-485 standard contains additional specifications to guarantee device safety in the event of line contention.

CABLE AND DATA RATE

The transmission line of choice for RS-485 communications is a twisted pair. Twisted-pair cable tends to cancel common-mode noise and also causes cancellation of the magnetic fields generated by the current flowing through each wire, thereby reducing the effective inductance of the pair.

The ADM3485E is designed for bidirectional data communications on multipoint transmission lines. A typical application showing a multipoint transmission network is illustrated in Figure 27. Only one driver can transmit at a particular time, but multiple receivers may be enabled simultaneously.

As with any transmission line, it is important that reflections are minimized. This may be achieved by terminating the extreme ends of the line using resistors equal to the characteristic impedance of the line. Stub lengths of the main line should also be kept as short as possible. A properly terminated transmission line appears purely resistive to the driver.

RECEIVER OPEN-CIRCUIT FAIL-SAFE

The receiver input includes a fail-safe feature that guarantees a logic high on the receiver when the inputs are open circuit or floating.

Table 11. RS-422 and RS-485 Interface Standards

Specification	RS-422	RS-485
Transmission Type	Differential	Differential
Maximum Cable Length	4000 ft.	4000 ft.
Minimum Driver Output Voltage	$\pm 2\text{ V}$	$\pm 1.5\text{ V}$
Driver Load Impedance	$100\ \Omega$	$54\ \Omega$
Receiver Input Resistance	$4\text{ k}\Omega$ min	$12\text{ k}\Omega$ min
Receiver Input Sensitivity	$\pm 200\text{ mV}$	$\pm 200\text{ mV}$
Receiver Input Voltage Range	-7 V to $+7\text{ V}$	-7 V to $+12\text{ V}$

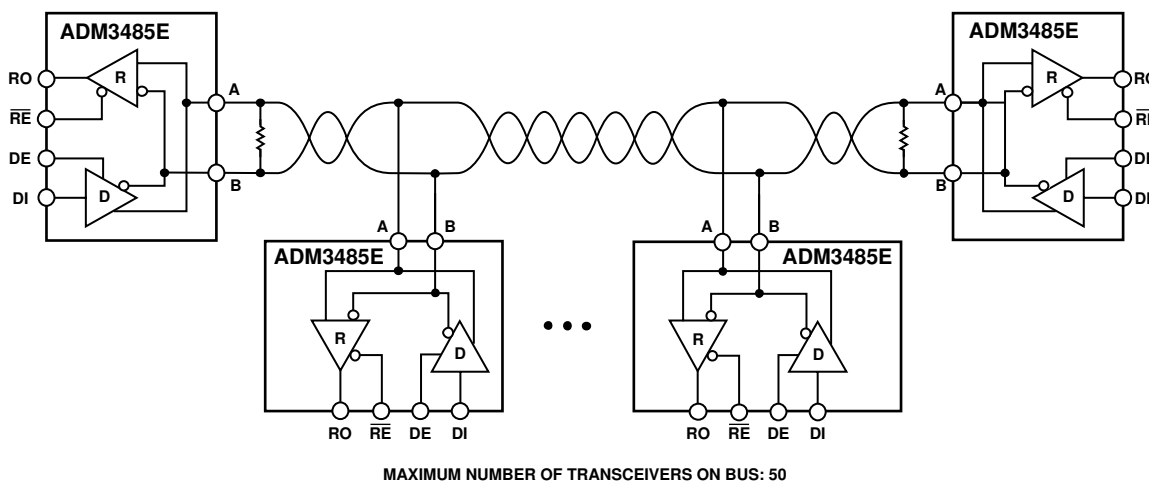
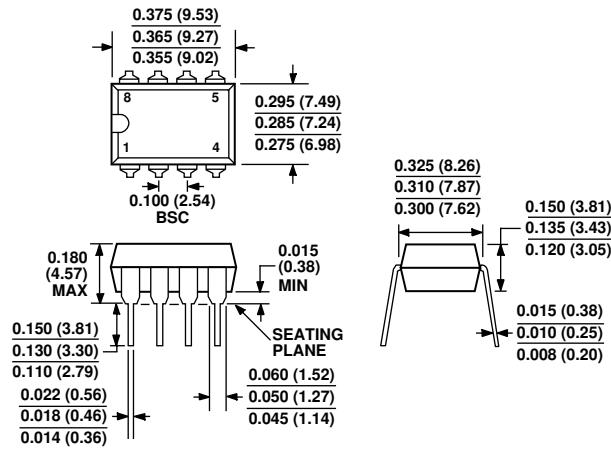

Figure 27. Multipoint Transmission Network

OUTLINE DIMENSIONS



COMPLIANT TO JEDEC STANDARDS MO-095AA
 CONTROLLING DIMENSIONS ARE IN INCHES; MILLIMETER DIMENSIONS
 (IN PARENTHESES) ARE ROUNDED-OFF INCH EQUIVALENTS FOR
 REFERENCE ONLY AND ARE NOT APPROPRIATE FOR USE IN DESIGN

Figure 28. 8-Lead Plastic Dual In-Line Package [PDIP]
 (N-8)
 Dimensions shown in inches and (millimeters)

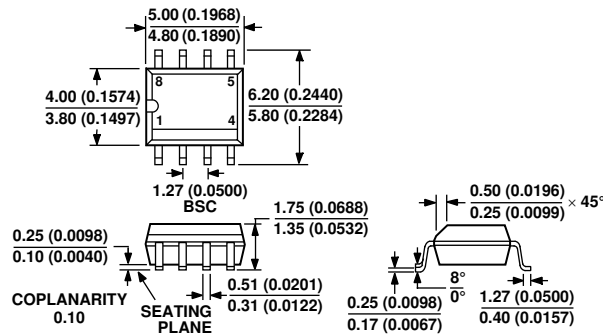

COMPLIANT TO JEDEC STANDARDS MS-012AA
 CONTROLLING DIMENSIONS ARE IN MILLIMETERS; INCH DIMENSIONS
 (IN PARENTHESES) ARE ROUNDED-OFF MILLIMETER EQUIVALENTS FOR
 REFERENCE ONLY AND ARE NOT APPROPRIATE FOR USE IN DESIGN

Figure 29. 8-Lead Standard Small Outline Package [SOIC]
 Narrow Body
 (R-8)
 Dimensions shown in millimeters and (inches)

ORDERING GUIDE

Model	Temperature Range	Package Description	Package Options
ADM3485EAN	-40°C to +85°C	Plastic DIP	N-8
ADM3485EAR	-40°C to +85°C	Small Outline (SOIC)	R-8
ADM3485EAR-REEL	-40°C to +85°C	Small Outline (SOIC)	R-8
ADM3485EAR-REEL7	-40°C to +85°C	Small Outline (SOIC)	R-8
ADM3485EARZ ¹	-40°C to +85°C	Small Outline (SOIC)	R-8
ADM3485EARZ-REEL ¹	-40°C to +85°C	Small Outline (SOIC)	R-8
ADM3485EARZ-REEL7 ¹	-40°C to +85°C	Small Outline (SOIC)	R-8

¹ Z = Pb-free part.

NOTES

ADM3485E

NOTES