

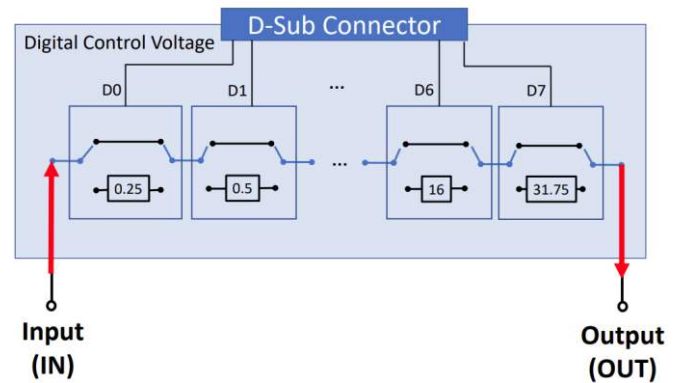

RoHS Compliant



Electrical Schematic

Electrical Specifications

Parameter	Unit	Frequency (MHz)	Conditions	Min.	Typ.	Max.	
Attenuation Range	dB	200 - 6000		0		63.5	
Step	dB				0.25		
Insertion Loss	dB			@ 0 dB Atn.		5.5	5.7
Attenuation Accuracy	dB			@ 0.25 dB Atn.		±0.03	±0.04
				@ 0.5, 1, 2 dB Atn.		±0.07	±0.13
				@ 4, 8, 16 dB Atn.		±0.27	±0.32
				@ 31.75 dB Atn.		±0.74	±1.00
				@ 63.5 dB Atn.		±3.30	±3.50
Input Operating Power (RF In and RF Out ports)	dBm						24
IP3 Input	dBm					47	
VSWR	:1			@ 0 dB Atn.	Input	1.93	1.94
					Output	1.74	
Switching Speed	ns			10% to 90% RF Output		90	
				50% Control to 90% RF Output		205	
Supply Voltage Range (V _{DD})	V				3		5.4
Control Voltage Threshold	V		Low	V _{DD} = 3.3 V	0		0.5
				V _{DD} = 5 V	0		0.8
			High	V _{DD} = 3.3 V	2		3.3
				V _{DD} = 5 V	3.5		5

Digital Control Voltage Range	V			0		V_{DD}
Supply Current (I_{DD})	mA			$V_{DD} = 3.3\text{ V}$	0.6	
				$V_{DD} = 5\text{ V}$	1.2	

Operated in 50Ω system, 25°C environment.

Outline Drawing

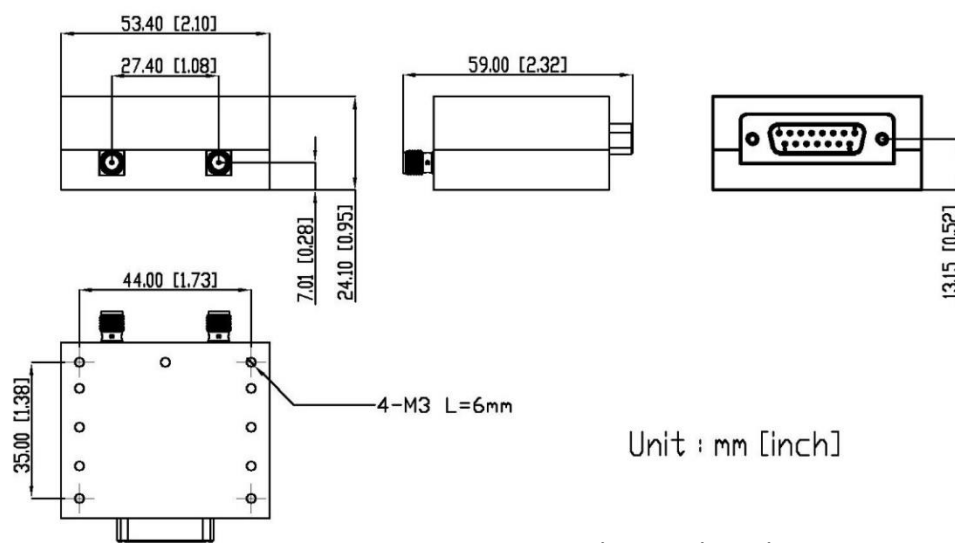

Connectors: SMA Female, D-Sub Male

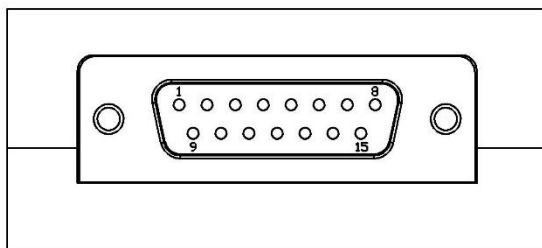

Pin Number Functions

No.	15	14	13	12	11
Func.	D0	D1	D2	D3	D4
No.	10	9	8	7	6
Func.	D5	D6	V_{DD}	N/C	PS(0V)
No.	5	4	3	2	1
Func.	N/C	N/C	GND	N/C	D7

Digital Control Input								Attenuation State (dB)
D0	D1	D2	D3	D4	D5	D6	D7	
Low	Low	Low	Low	Low	Low	Low	Low	0 (reference)
High	Low	Low	Low	Low	Low	Low	Low	0.25
Low	High	Low	Low	Low	Low	Low	Low	0.5
Low	Low	High	Low	Low	Low	Low	Low	1
Low	Low	Low	High	Low	Low	Low	Low	2
Low	Low	Low	Low	High	Low	Low	Low	4
Low	Low	Low	Low	Low	High	Low	Low	8
Low	Low	Low	Low	Low	Low	High	Low	16
Low	Low	Low	Low	Low	Low	Low	High	31.75
High	High	High	High	High	High	High	High	63.5

Typical Performance

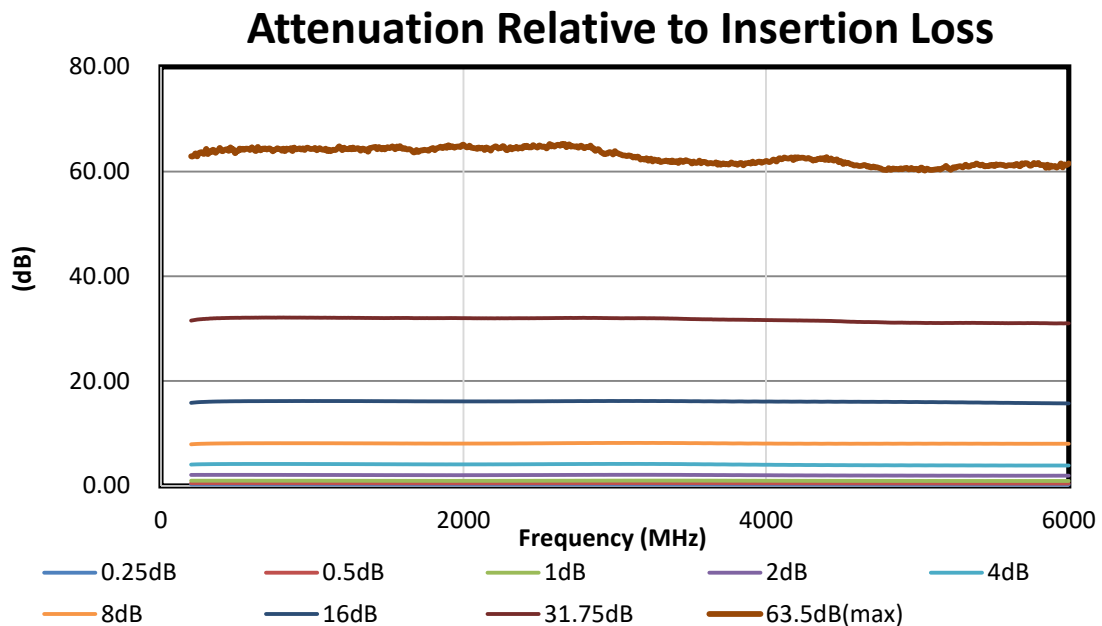

Insertion Loss

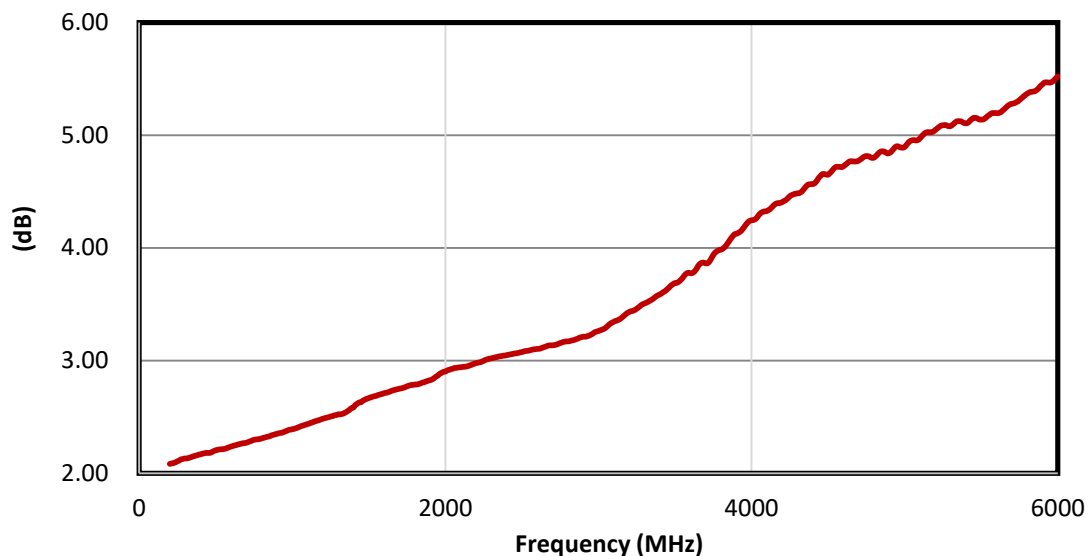

Input VSWR

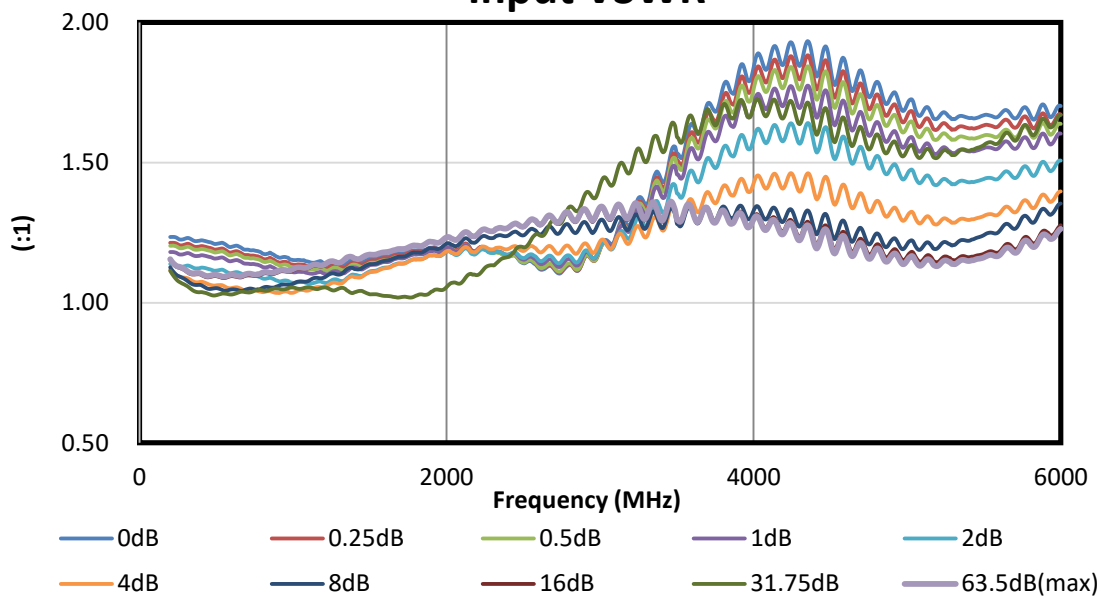

Output VSWR

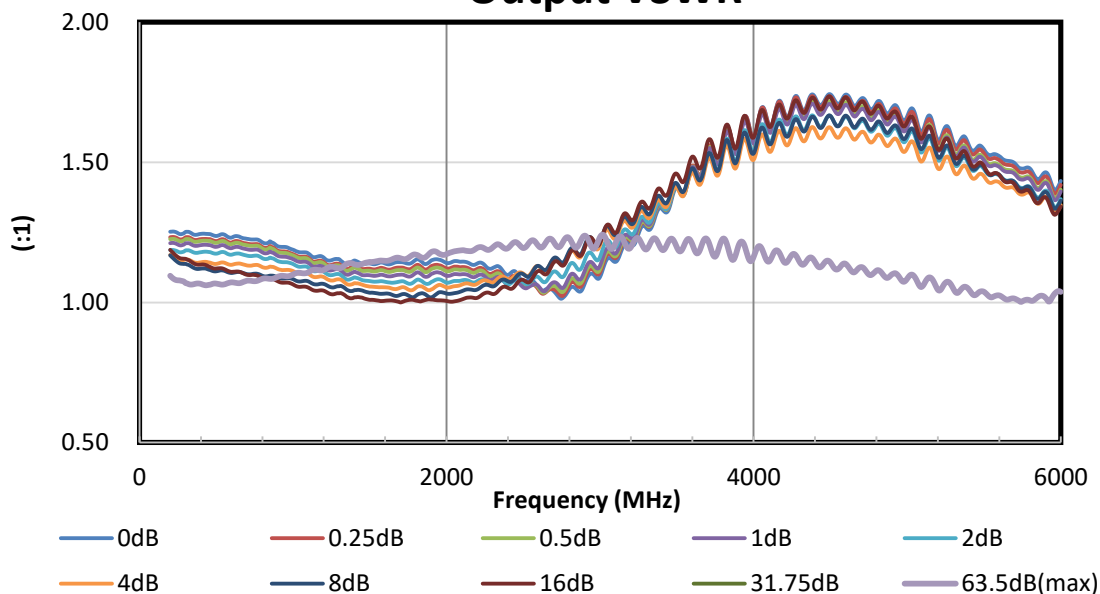

Typical Attenuation Accuracy

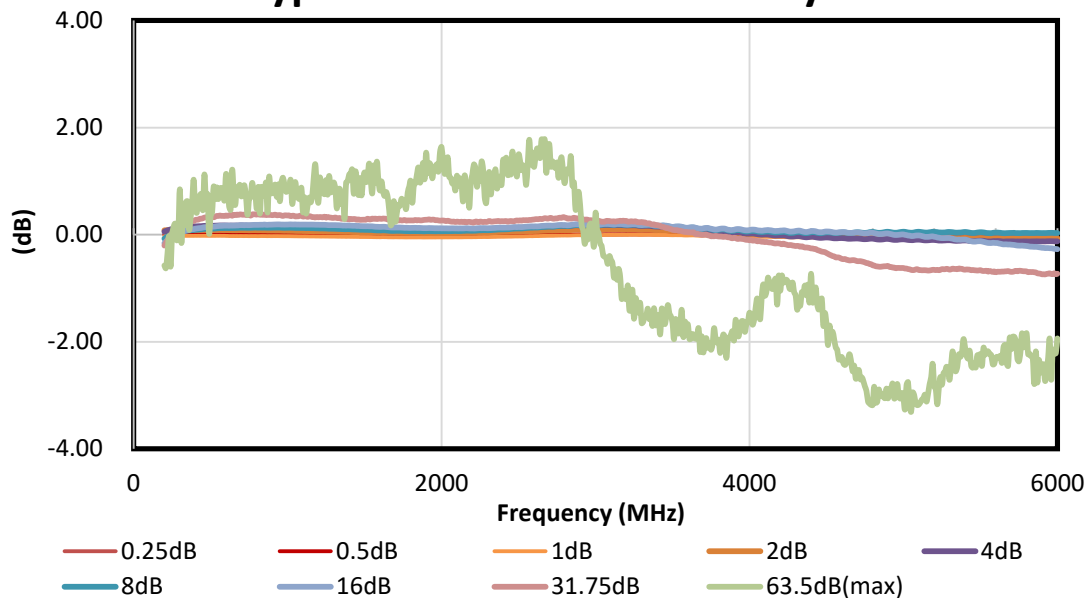

Typical performance S-parameter file: <https://www.amtery.com/en/goods-80>

For each S/N S-parameter file, go to <https://www.amtery.com/en/downloads>

Note: Specifications are subject to change without notice.