



## 3.3V CMOS OCTAL D-TYPE FLIP-FLOP WITH RESET, POSITIVE EDGE TRIGGER, AND 5 VOLT TOLERANT I/O

**IDT74LVC273A**

### FEATURES:

- 0.5 MICRON CMOS Technology
- ESD > 2000V per MIL-STD-883, Method 3015; > 200V using machine model (C = 200pF, R = 0)
- Vcc = 3.3V ± 0.3V, Normal Range
- Vcc = 2.7V to 3.6V, Extended Range
- CMOS power levels (0.4μ W typ. static)
- Rail-to-rail output swing for increased noise margin
- All inputs, outputs, and I/O are 5V tolerant
- Supports hot insertion
- Available in SSOP and TSSOP packages

### DRIVE FEATURES:

- High Output Drivers: ±24mA
- Reduced system switching noise

### APPLICATIONS:

- 5V and 3.3V mixed voltage systems
- Data communication and telecommunication systems

### DESCRIPTION:

The octal D-type flip-flop with reset, positive edge trigger is built using advanced dual metal CMOS technology. This high-speed, low power device is ideal for driving high capacitance loads such as memory address and data buses.

All pins can be driven from either 3.3V or 5V devices. This feature allows the use of these devices as translators in a mixed 3.3V/5V supply system.

## FUNCTIONAL BLOCK DIAGRAM

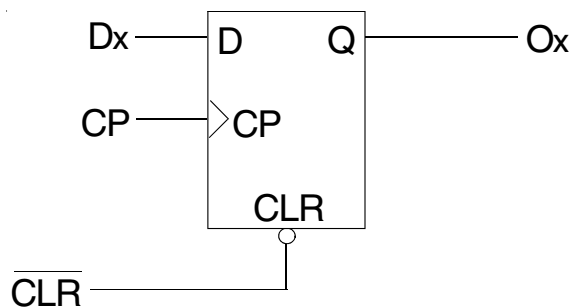

## PIN CONFIGURATION

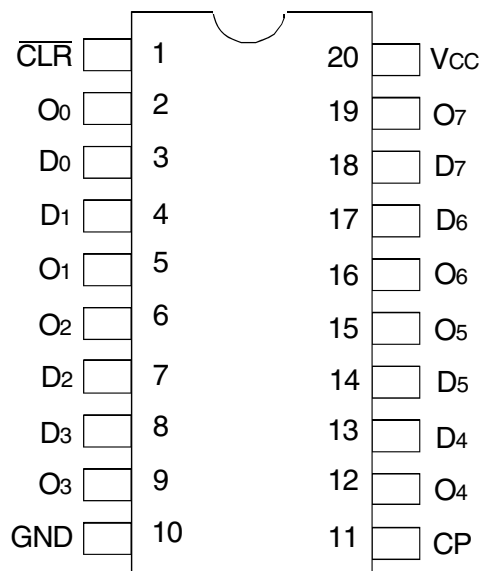

SSOP/ TSSOP  
TOP VIEW

## ABSOLUTE MAXIMUM RATINGS<sup>(1)</sup>

Symbol	Description	Max	Unit
VTERM	Terminal Voltage with Respect to GND	-0.5 to +6.5	V
TSTG	Storage Temperature	-65 to +150	°C
IOUT	DC Output Current	-50 to +50	mA
I <sub>IK</sub> I <sub>OK</sub>	Continuous Clamp Current, V <sub>I</sub> < 0 or V <sub>O</sub> < 0	-50	mA
I <sub>CC</sub> I <sub>SS</sub>	Continuous Current through each V <sub>CC</sub> or GND	±100	mA

### NOTE:

- Stresses greater than those listed under ABSOLUTE MAXIMUM RATINGS may cause permanent damage to the device. This is a stress rating only and functional operation of the device at these or any other conditions above those indicated in the operational sections of this specification is not implied. Exposure to absolute maximum rating conditions for extended periods may affect reliability.

## CAPACITANCE (T<sub>A</sub> = +25°C, F = 1.0MHz)

Symbol	Parameter <sup>(1)</sup>	Conditions	Typ.	Max.	Unit
C <sub>IN</sub>	Input Capacitance	V <sub>IN</sub> = 0V	4.5	6	pF
C <sub>OUT</sub>	Output Capacitance	V <sub>OUT</sub> = 0V	5.5	8	pF
C <sub>I/O</sub>	I/O Port Capacitance	V <sub>IN</sub> = 0V	6.5	8	pF

### NOTE:

- As applicable to the device type.

## PIN DESCRIPTION

Pin Names	Description
$\overline{\text{CLR}}$	Clear Input
CP	Clock Input
O <sub>x</sub>	Data Outputs
D <sub>x</sub>	Data Inputs

## FUNCTION TABLE<sup>(1)</sup>

Inputs			Internal	Outputs	Function
$\overline{\text{CLR}}$	CP	D <sub>x</sub>	Q Value	O <sub>x</sub>	
L	X	X	L	L	Clear Register
H	↑	L	L	L	Load Input Data
H	↑	H	H	H	Load Input Data

### NOTE:

- H = HIGH Voltage Level  
L = LOW Voltage Level  
X = Don't Care  
↑ = LOW-to-HIGH Transition

## DC ELECTRICAL CHARACTERISTICS OVER OPERATING RANGE

Following Conditions Apply Unless Otherwise Specified:

Operating Condition:  $T_A = -40^{\circ}\text{C}$  to  $+85^{\circ}\text{C}$

Symbol	Parameter	Test Conditions		Min.	Typ. <sup>(1)</sup>	Max.	Unit
V <sub>IH</sub>	Input HIGH Voltage Level	V <sub>CC</sub> = 2.3V to 2.7V		1.7	—	—	V
		V <sub>CC</sub> = 2.7V to 3.6V		2	—	—	
V <sub>IL</sub>	Input LOW Voltage Level	V <sub>CC</sub> = 2.3V to 2.7V		—	—	0.7	V
		V <sub>CC</sub> = 2.7V to 3.6V		—	—	0.8	
I <sub>IH</sub> I <sub>IL</sub>	Input Leakage Current	V <sub>CC</sub> = 3.6V	V <sub>I</sub> = 0 to 5.5V	—	—	±5	μA
I <sub>OZH</sub> I <sub>OZL</sub>	High Impedance Output Current (3-State Output pins)	V <sub>CC</sub> = 3.6V	V <sub>O</sub> = 0 to 5.5V	—	—	±10	μA
I <sub>OFF</sub>	Input/Output Power Off Leakage	V <sub>CC</sub> = 0V, V <sub>IN</sub> or V <sub>O</sub> ≤ 5.5V		—	—	±50	μA
V <sub>IK</sub>	Clamp Diode Voltage	V <sub>CC</sub> = 2.3V, I <sub>IN</sub> = -18mA		—	-0.7	-1.2	V
V <sub>H</sub>	Input Hysteresis	V <sub>CC</sub> = 3.3V		—	100	—	mV
I <sub>CC1</sub> I <sub>CC2</sub> I <sub>CC3</sub>	Quiescent Power Supply Current	V <sub>CC</sub> = 3.6V	V <sub>IN</sub> = GND or V <sub>CC</sub>	—	—	10	μA
			3.6 ≤ V <sub>IN</sub> ≤ 5.5V <sup>(2)</sup>	—	—	10	
ΔI <sub>CC</sub>	Quiescent Power Supply Current Variation	One input at V <sub>CC</sub> - 0.6V, other inputs at V <sub>CC</sub> or GND		—	—	500	μA

### NOTES:

1. Typical values are at V<sub>CC</sub> = 3.3V, +25°C ambient.
2. This applies in the disabled state only.

## OUTPUT DRIVE CHARACTERISTICS

Symbol	Parameter	Test Conditions <sup>(1)</sup>		Min.	Max.	Unit
V <sub>OH</sub>	Output HIGH Voltage	V <sub>CC</sub> = 2.3V to 3.6V	I <sub>OH</sub> = -0.1mA	V <sub>CC</sub> - 0.2	—	V
		V <sub>CC</sub> = 2.3V	I <sub>OH</sub> = -6mA	2	—	
		V <sub>CC</sub> = 2.3V	I <sub>OH</sub> = -12mA	1.7	—	
		V <sub>CC</sub> = 2.7V		2.2	—	
		V <sub>CC</sub> = 3V		2.4	—	
		V <sub>CC</sub> = 3V	I <sub>OH</sub> = -24mA	2.2	—	
V <sub>OL</sub>	Output LOW Voltage	V <sub>CC</sub> = 2.3V to 3.6V	I <sub>OL</sub> = 0.1mA	—	0.2	V
		V <sub>CC</sub> = 2.3V	I <sub>OL</sub> = 6mA	—	0.4	
			I <sub>OL</sub> = 12mA	—	0.7	
		V <sub>CC</sub> = 2.7V	I <sub>OL</sub> = 12mA	—	0.4	
		V <sub>CC</sub> = 3V	I <sub>OL</sub> = 24mA	—	0.55	

### NOTE:

1. V<sub>IH</sub> and V<sub>IL</sub> must be within the min. or max. range shown in the DC ELECTRICAL CHARACTERISTICS OVER OPERATING RANGE table for the appropriate V<sub>CC</sub> range. T<sub>A</sub> = -40°C to +85°C.

OPERATING CHARACTERISTICS,  $V_{CC} = 3.3V \pm 0.3V$ ,  $T_A = 25^\circ C$

Symbol	Parameter	Test Conditions	Typical	Unit
CPD	Power Dissipation Capacitance per Transceiver Outputs enabled	$C_L = 0pF$ , $f = 10Mhz$	—	pF
CPD	Power Dissipation Capacitance per Transceiver Outputs disabled		—	

SWITCHING CHARACTERISTICS<sup>(1)</sup>

Symbol	Parameter	$V_{CC} = 2.7V$		$V_{CC} = 3.3V \pm 0.3V$		Unit
		Min.	Max.	Min.	Max.	
$t_{PLH}$	Propagation Delay, CP to O <sub>x</sub>	1.5	9.5	1.5	8.5	ns
$t_{PHL}$	Propagation Delay, $\overline{CLR}$ to O <sub>x</sub>	1.5	9.5	1.5	8.5	ns
$t_S$	Data Setup Time, D <sub>x</sub> to CP	2.5	—	2.5	—	ns
$t_H$	Data Hold Time, D <sub>x</sub> to CP	1.5	—	1.5	—	ns
$t_{REC}$	$\overline{CLR}$ Recovery Time, $\overline{CLR}$ to CP	2	—	2	—	ns
$t_{WCLR}$	$\overline{CLR}$ Pulse Width, LOW	3.3	—	3.3	—	ns
$t_{WCP}$	CLK Pulse Width, HIGH or LOW	3.3	—	3.3	—	ns
$t_{SK(O)}$	Output Skew <sup>(2)</sup>	—	—	—	500	ps

NOTES:

1. See TEST CIRCUITS AND WAVEFORMS.  $T_A = -40^\circ C$  to  $+85^\circ C$ .
2. Skew between any two outputs of the same package and switching in the same direction.

## TEST CIRCUITS AND WAVEFORMS

### TEST CONDITIONS

Symbol	V <sub>CC</sub> <sup>(1)</sup> =3.3V±0.3V	V <sub>CC</sub> <sup>(1)</sup> =2.7V	V <sub>CC</sub> <sup>(2)</sup> =2.5V±0.2V	Unit
V <sub>LOAD</sub>	6	6	2 x V <sub>CC</sub>	V
V <sub>IH</sub>	2.7	2.7	V <sub>CC</sub>	V
V <sub>T</sub>	1.5	1.5	V <sub>CC</sub> / 2	V
V <sub>LZ</sub>	300	300	150	mV
V <sub>HZ</sub>	300	300	150	mV
C <sub>L</sub>	50	50	30	pF

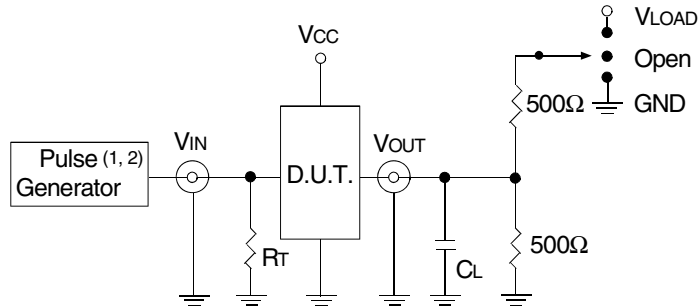

Test Circuit for All Outputs

#### DEFINITIONS:

C<sub>L</sub> = Load capacitance: includes jig and probe capacitance.  
R<sub>T</sub> = Termination resistance: should be equal to Z<sub>OUT</sub> of the Pulse Generator.

#### NOTES:

1. Pulse Generator for All Pulses: Rate ≤ 10MHz; t<sub>F</sub> ≤ 2.5ns; t<sub>R</sub> ≤ 2.5ns.
2. Pulse Generator for All Pulses: Rate ≤ 10MHz; t<sub>F</sub> ≤ 2ns; t<sub>R</sub> ≤ 2ns.

### SWITCH POSITION

Test	Switch
Open Drain Disable Low Enable Low	V <sub>LOAD</sub>
Disable High Enable High	GND
All Other Tests	Open

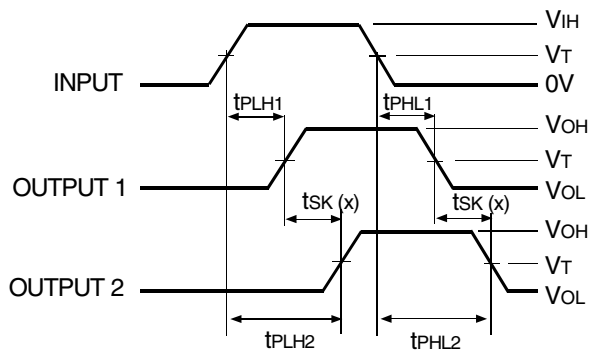

$$tsk(x) = |t_{PLH2} - t_{PLH1}| \text{ or } |t_{PHL2} - t_{PHL1}|$$

Output Skew - tsk(x)

#### NOTES:

1. For tsk(o) OUTPUT1 and OUTPUT2 are any two outputs.
2. For tsk(b) OUTPUT1 and OUTPUT2 are in the same bank.

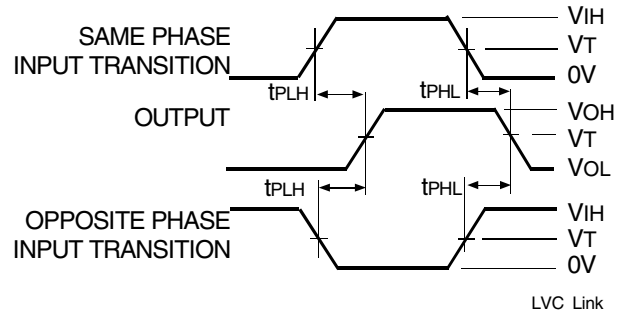

#### Propagation Delay

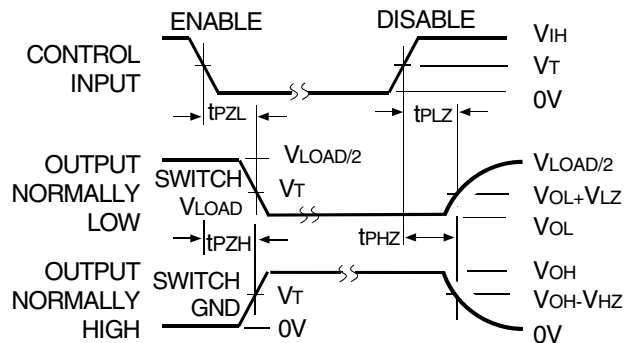

#### Enable and Disable Times

#### NOTE:

1. Diagram shown for input Control Enable-LOW and input Control Disable-HIGH.

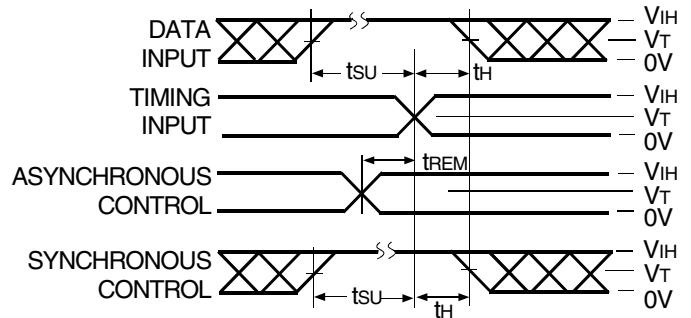

#### Set-up, Hold, and Release Times

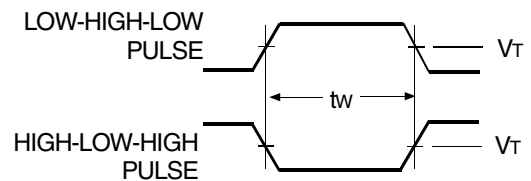

#### Pulse Width

**ORDERING INFORMATION**

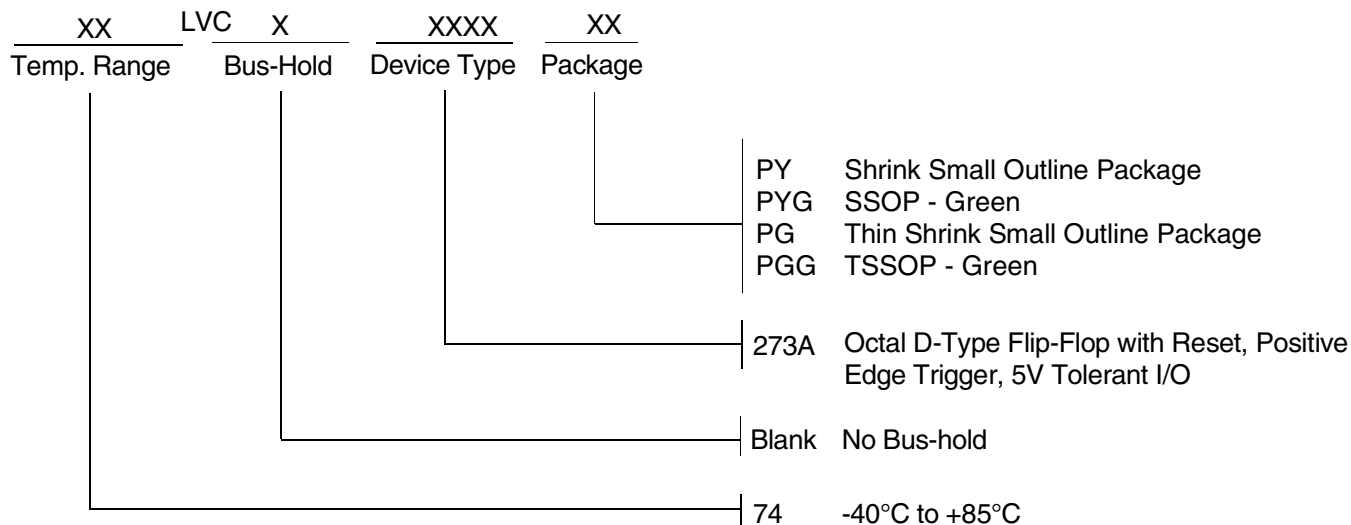

**CORPORATE HEADQUARTERS**  
 6024 Silver Creek Valley Road  
 San Jose, CA 95138

**for SALES:**  
 800-345-7015 or 408-284-8200  
 fax: 408-284-2775  
 www.idt.com

**for Tech Support:**  
 logichelp@idt.com