

DRAWING MADE IN AMERICAN PROJECTION

LOC **G** PRINT DIST **14 C**

©1947 BY AMP INCORPORATED. ALL RIGHTS RESERVED. AMP PRODUCTS COVERED BY PATENTS AND/OR PATENTS PENDING.

REVISIONS

LTR	DESCRIPTION	DATE	APPROVED
A	REDRAWN & UPDATED PC-5558	10-3-69	JM
B	REV. & ADDED TAPE NO.	5-11-71	FEY
C	INACTIVATED 2-1 P-9241	11-30-81	JFM
C1	REV PER ECR 06-024909	10/26/06	JR/TM

34101

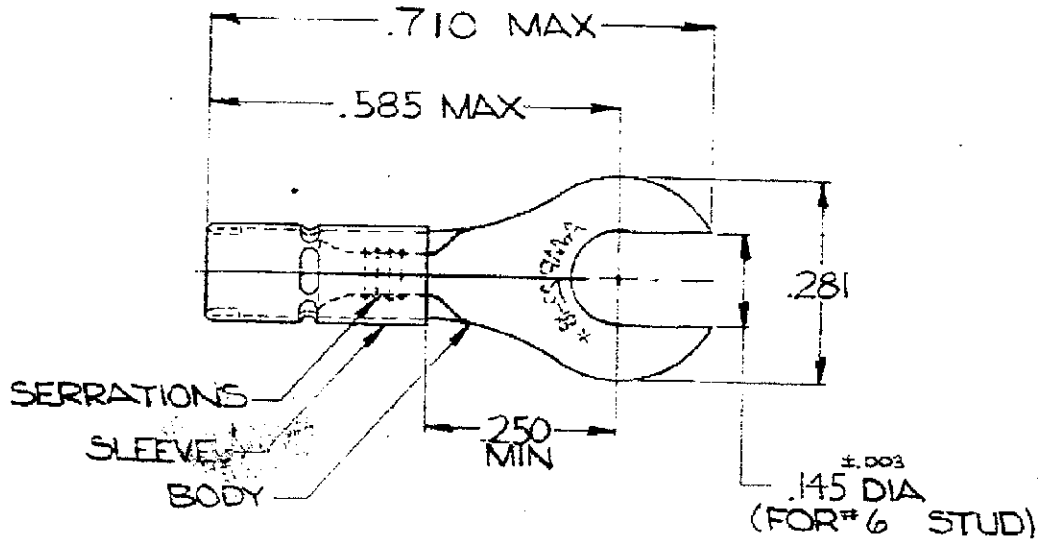

TONGUE MATERIAL THICKNESS =  $\pm .002$  .031  
 FOR .080 TO .125 WIRE INSULATION DIA  
 MARKING 22-18 FOR MILITARY  
 COMMERCIAL RANGE 22-16

34101	2-34101-1
PART NO.	PART NO. ON TAPE

UNLESS OTHERWISE SPECIFIED DIMENSIONS ARE IN INCHES TOLERANCES ON: DECIMALS ± .008 ANGLES ± 5°	CONTRACT NO. —	<b>AMP</b> AMP INCORPORATED HARRISBURG, PENNSYLVANIA
	DR. <i>H. Benoit 9/2/69</i>	
MATERIAL COPPER (QQ-C-576)  TIN PL (L-T-10727)	CHK. <i>JM Eversman 10-5-69</i>	WIRE TERMINAL DIAMOND GRIP-SLOTTED RING TONGUE WIRE SIZE: 22-16
	APPD. <i>Swabel 10-6-69</i>	
	REC. <i>JM Eversman 10-6-69</i>	A 00779 34101
	DSGN APPD	SCALE NTS SHEET 1 OF 1
	OTHER APPD	