

PART NAME

TABLET ENCLOSURE

PART No.

TB-32613-B & TB-32613-W

REV. DATE

2-23-13

MATERIAL:
ABS UL94-HB BLACK (SUFFIX-B)
ABS UL94-V0 WHITE (SUFFIX-W)

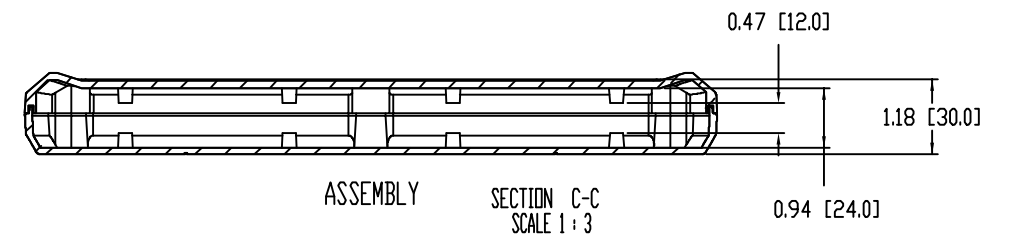
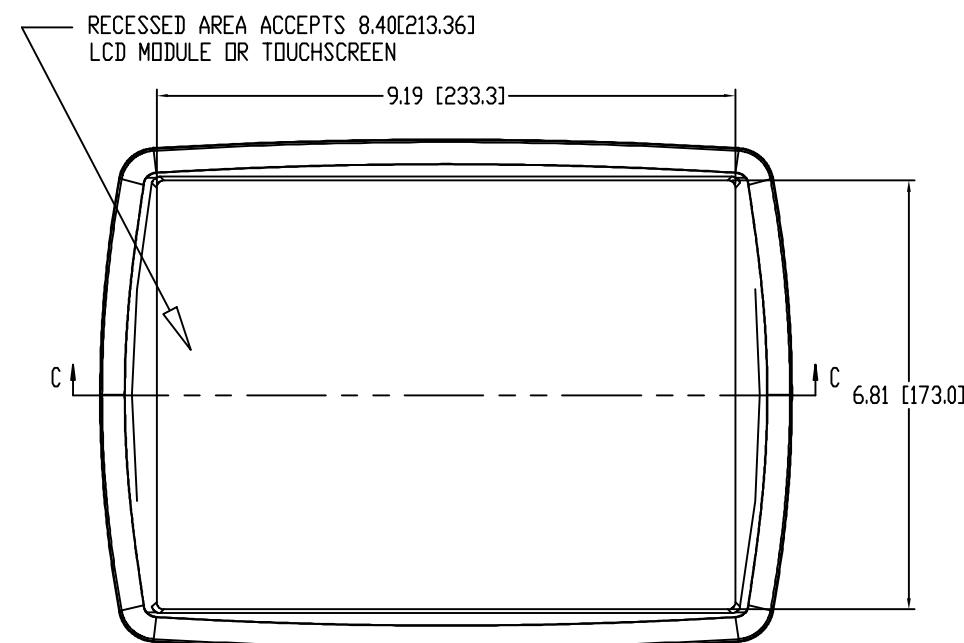
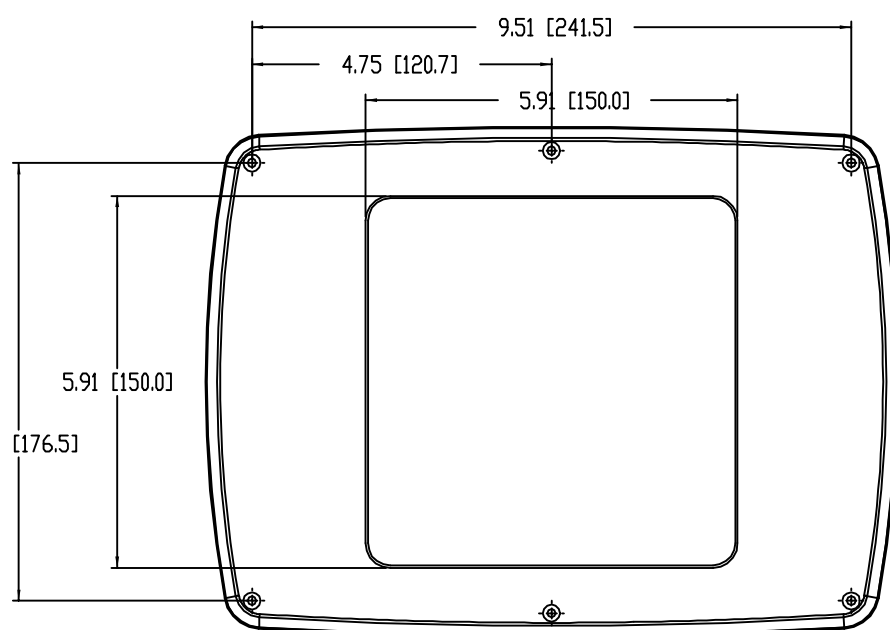
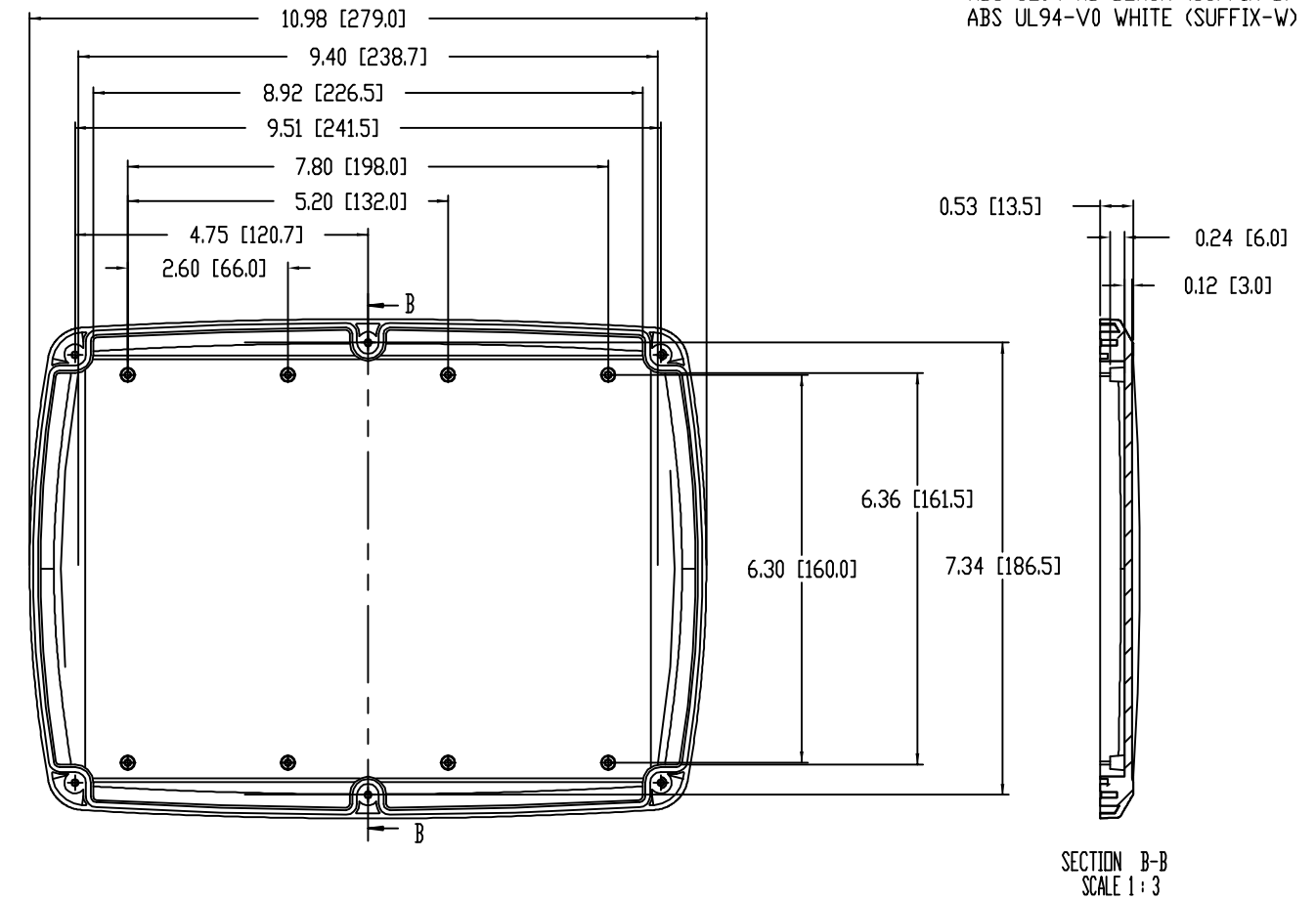
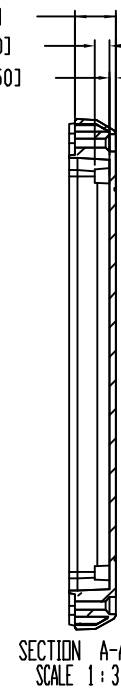
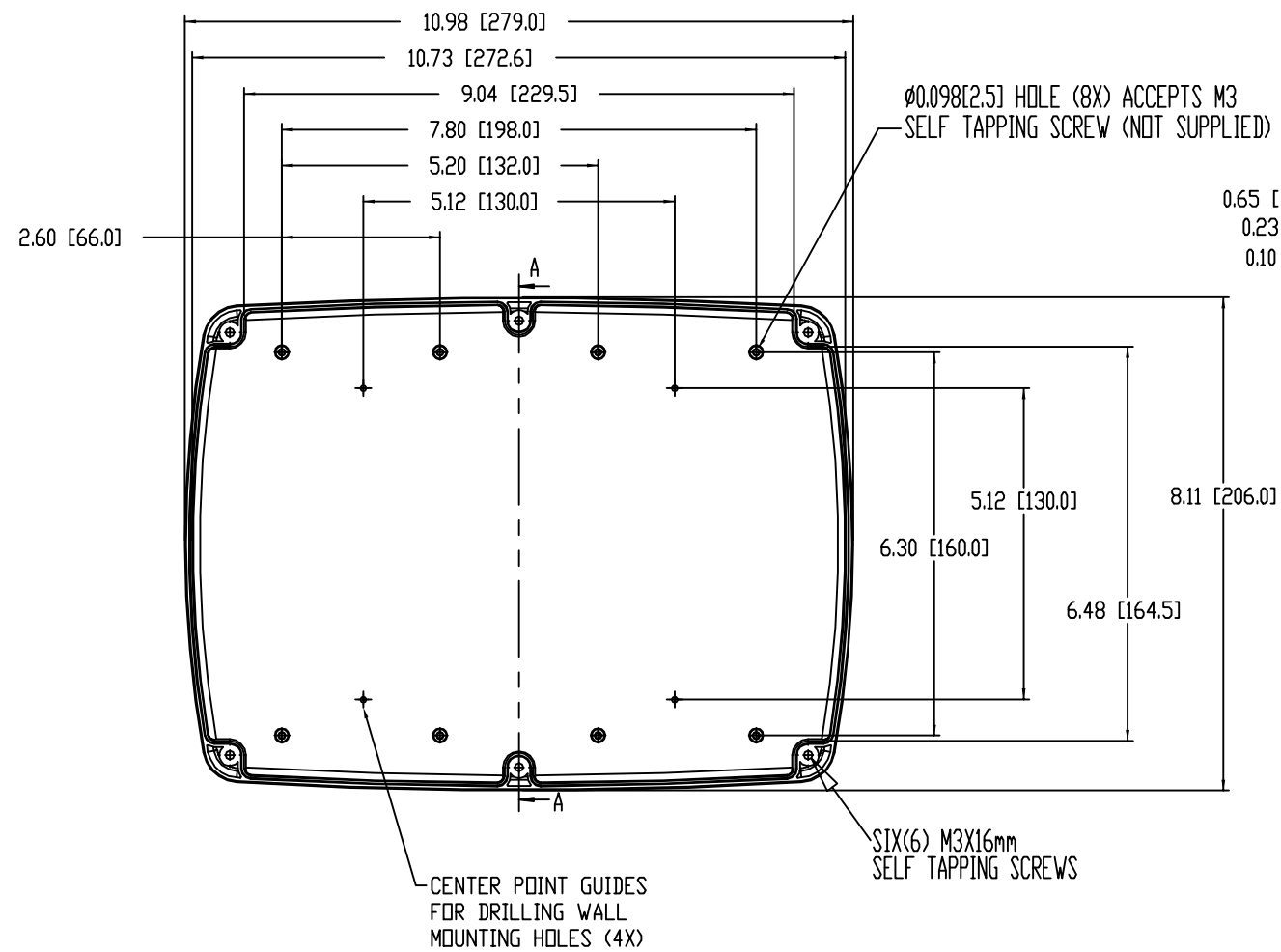

- NOTES:
- 1.) SIX (6) M3 X .63[16] LG. SELF-TAPPING SCREWS SUPPLIED FOR ASSEMBLY
 - 2.) FOUR (4) ADD-ON RUBBER FEET SUPPLIED
 - 3.) ALL HOLE DIAMETERS HAVE +/- .005[.13] TOLERANCE
ALL OTHER DIMENSIONS HAVE +/- .015[.38] TOLERANCE
 - 4.) DIMENSIONS ARE INCH[MILLIMETER]-THIRD ANGLE PROJECTION
 - 5.) OPTIONAL SILICONE SPONGE GASKET #TB-32613-GSK AVAILABLE