

PART NO.	ENGINEERING NO.	FINISHED LENGTH
1300062383	103000K13M020	2.0M+88.9mm-0 [6.6 FT. +3.50-0]
1300062384	103000K13M040	4.0M+165.1 mm-0 [13.1 FT. +6.50-0]

CHART
B

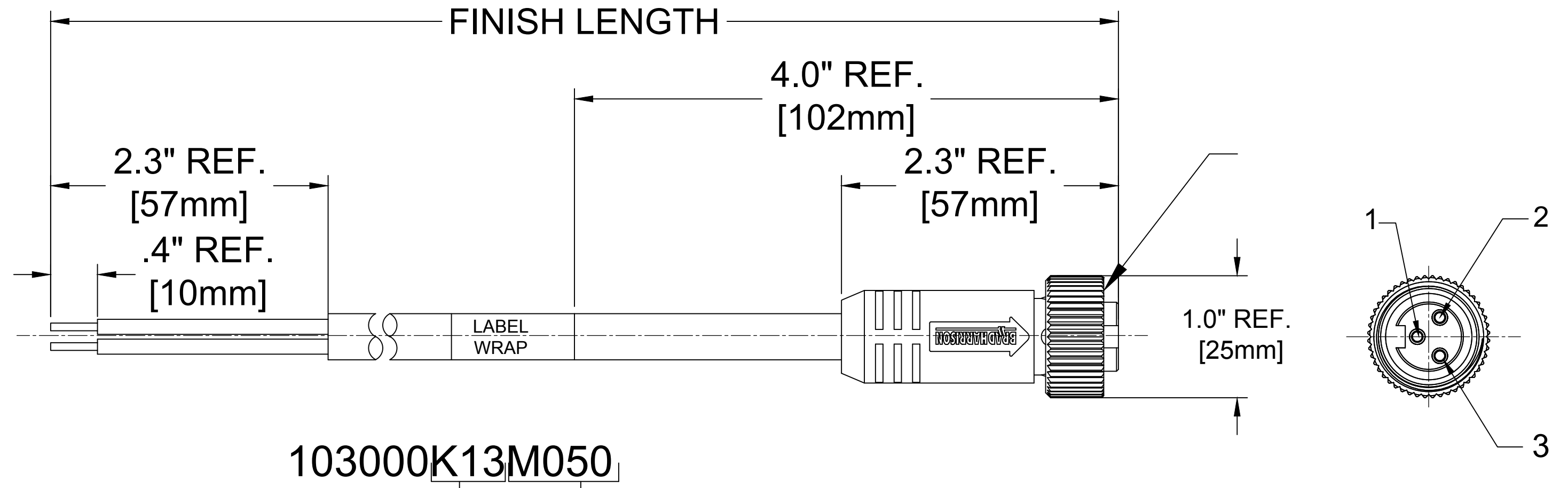

103000K13M050

cable type
16AWG-3
FLEX TPE

cable length
M005 = 0.5 METER
M010 = 1.0 METER
M100 = 10.0 METER

NOTES: B

- MATERIAL: AS NOTED
- FINISH: AS NOTED
- ELECTRICAL:
3 POLE: VOLTAGE: 500V PER IEC60664
600V PER UL2238
CURRENT: 13A
- TEMP RATING: -40°TO +90°C
- PROTECTION: IP67 (WHEN MATED)
- ALL DIMS ARE FOR REFERENCE
UNLESS NOTED OTHERWISE
- UL LISTED PER FILE: E152210

WIRING DIAGRAM

P1	
1	GREEN/YELLOW
2	BLACK
3	WHITE

B

CABLE LENGTH TOLERANCES	
>.3M [1FT]:	+19mm-0 [+ .75in-0]
.3 - .9M [1 - 3FT]:	+44.5mm-0 [+1.75in-0]
.9 - 1.8M [3 - 6FT]:	+55.6mm-0 [+2.19in-0]
1.8 - 3.7M [6 - 12FT]:	+88.9mm-0 [+3.50in-0]
3.7 - 7.3M [12 - 24FT]:	+165.1mm-0 [+6.50in-0]
7.3-14.6M [24 - 48FT]:	+317.5mm-0 [+12.50in-0]
14.6 - 30.5M [48-100FT]:	+622.3mm-0 [+24.50in-0]
OVER 30M [100FT]	+2% OF FINISHED LENGTH

MECHANICAL CHARACTERISTICS: B

TORSIONAL FLEX TEST	20 MILLION CYCLES PER MIL-C-13777G
BEND FLEX TEST	20 MILLION CYCLES PER MIL-C-13777G
WELD SLAG RESISTANCE	WOODHEAD STANDARD S-300

REV	DESCRIPTION	MATERIAL	FINISH
9	WRAP LABEL	MYLAR	BLACK/YELLOW
8	CONTACT PIN	COPPER ALLOY	Au OVER Ni
7	INSERT	ARNITEL	YELLOW
6	OVERMOLD	ARNITEL	YELLOW
5	CABLE, 16AWG,	STOOD FLX TPE	YELLOW
4	COUPLING NUT	ZINC DIE CAST	BLACK/E-COATED
	DESCRIPTION	MATERIAL	FINISH

ADD TABLE FOR PARTS EC NO.: IPG2018-0001 DRWN: AAKHTAR 2017/07/06 CHKD: MZIELIN 2017/07/06 APPR: BWOODMAN2013/11/12	QUALITY SYMBOL	GENERAL TOLERANCES (UNLESS SPECIFIED)	DIMENSION STYLE IN / MM	SCALE NTS	DESIGN UNITS INCH	THIRD ANGLE PROJECTION
	▽=0 ∇=0	4 PLACES ±--- ±--- 3 PLACES ±--- ±.005 2 PLACES ±0.13 ±.010 1 PLACE ±0.25 ±.020	DRAWN BY DATE GGUSTAFS 2013/10/03	TITLE	MINI CHANGE 3 POLE FEMALE STR 16/3 AWG TPE	
		ANGULAR ±.5°	CHECKED BY DATE TWOLDEGE 2013/11/05	MOLEX INCORPORATED		
		DRAFT WHERE APPLICABLE MUST REMAIN WITHIN DIMENSIONS	APPROVED BY DATE BWOODMAN 2013/11/12	MATERIAL NO. SEE CHART	DOCUMENT NO. SD-130006-059	SHEET NO. 1 OF 1
			SIZE C	THIS DRAWING CONTAINS INFORMATION THAT IS PROPRIETARY TO MOLEX INCORPORATED AND SHOULD NOT BE USED WITHOUT WRITTEN PERMISSION		