

HCMS-2819

High Performance CMOS 5x7 AlphaNumeric InGaN Blue Display



Data Sheet

Description

This product is a high performance, easy to use dot matrix display driven by on-board CMOS IC. Each display can be directly interfaced with a microprocessor, thus eliminating the need for cumbersome interface components. The serial IC interface allows higher character count information displays with a minimum of data lines. The 5x7 pixel format allows the user great freedom to generate user-defined characters. This product is stackable in the x- and y-directions, making it ideal for high character count displays

Features

- Easy to Use
- Interfaces Directly with Microprocessors
- 0.15" Character Height in 8 Character Package
- Rugged X- and Y-Stackable Package
- Serial Input
- Convenient Brightness Controls
- Wave Solderable
- Low Power CMOS Technology
- TTL Compatible

Applications

- Telecommunications Equipment
- Portable Data Entry Devices
- Computer Peripherals
- Medical Equipment
- Test Equipment
- Business Machines
- Avionics
- Industrial Controls

Package Dimensions

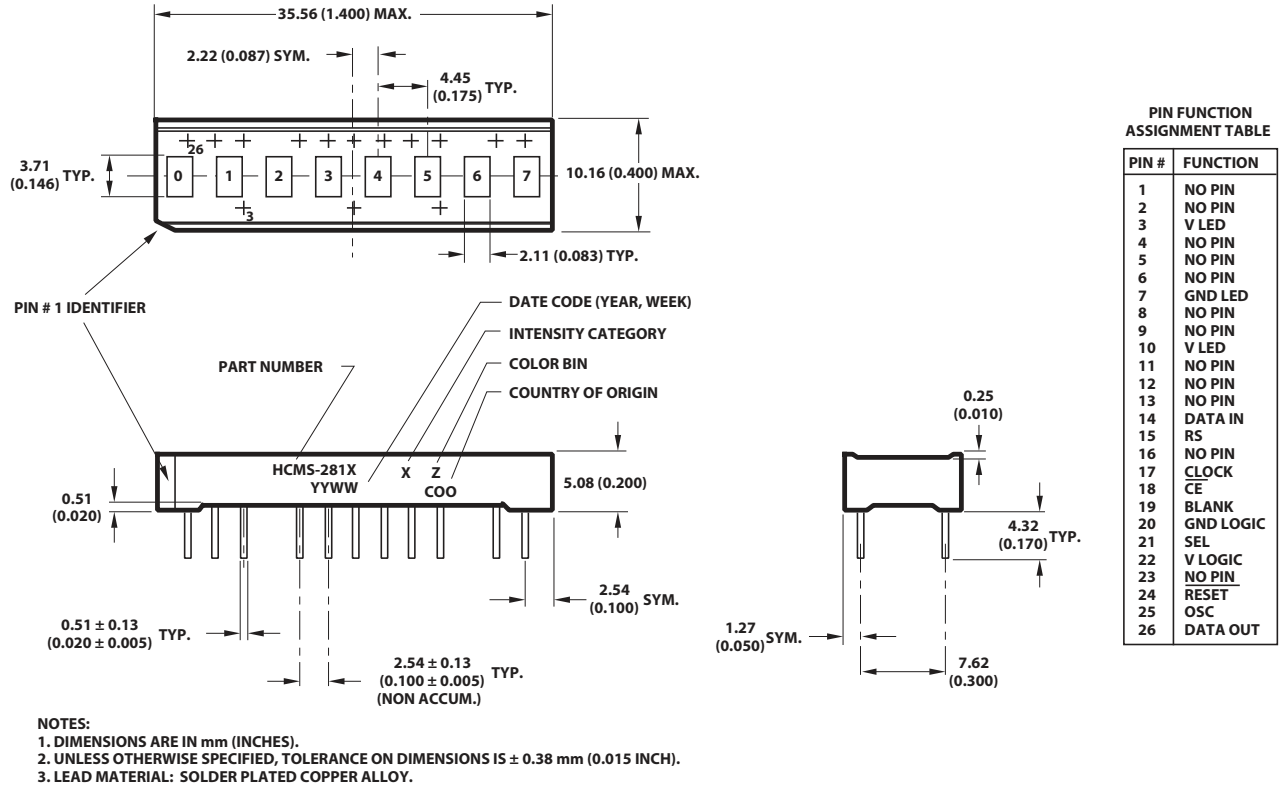

Figure 1. HCMS-2819 package dimension

Device Selection Guide

Description	
8 Digit 0.15" Character Height	HCMS-2819

Absolute Maximum Ratings

Logic Supply Voltage, V_{LOGIC} to $\text{GND}_{\text{LOGIC}}$	-0.3V to 7.0V
LED Supply Voltage, V_{LED} to GND_{LED}	-0.3V to 5.5V
Input Voltage, Any Pin to GND	-0.3V to $V_{\text{LOGIC}} + 0.3V$
Free Air Operating Temperature Range T_A	-40°C to +85°C
Relative Humidity (non-condensing)	85%
Storage Temperature, T_S	-55°C to 100°C
Maximum Solder Temperature	
Solder Dipping	260°C for 5 sec
Wave Soldering	250°C for 3 sec
ESD Protection @ 1.5 k Ω , 100pF (each pin)	Class 1, 0-1999V
TOTAL Package Power Dissipation at $T_A=25^\circ\text{C}$	2.4 W

Notes:
 For operation in high ambient temperatures, see Appendix A, Thermal Considerations.

Recommend Operating Conditions Over Temperature Range (-40°C to +85°C)

Parameter	Symbol	Min.	Max.	Units
Logic Supply Voltage ^[1]	V _{LOGIC}	3.0	5.5	V
LED Supply Voltage ^[1]	V _{LED}	4.5	5.5	V
GND _{LED} to GND _{LOGIC}	-	-0.3	+0.3	V

Notes:

For further description, see Appendix B, Electrical Considerations, "V_{LOGIC} and V_{LED} Considerations".

Electrical Characteristics Over Operating Temperature Range (-40°C to +85°C)

Parameter	Symbol	T _A = 25°C, V _{LOGIC} = 5.0V		-40°C < T _A < 85°C 3.0V < V _{LOGIC} < 5.5V		Units	Test Conditions
		Typ	Max	Typ	Max		
Input Leakage Current	I _I		+15	-5.0	+100	μA	V _{IN} = 0 TO V _{LOGIC}
I _{LOGIC} OPERATING	I _{LOGIC} (OPT)	0.8	5		10	mA	V _{IN} = V _{LOGIC}
I _{LOGIC} SLEEP ^[1]	I _{LOGIC} (SLP)	10	30		50	μA	V _{IN} = V _{LOGIC}
I _{LED} BLANK	I _{LED} (BL)	4.0	8.0		8.0	mA	BL = 0 V
I _{LED} SLEEP ^[1]	I _{LED} (SLP)	15.0	50		100	μA	
Peak Pixel Current ^[2]	I _{PIXEL}	14.0	20		23	mA	V _{LED} = 5.5 V All pixels ON, Average value per pixel
HIGH level input voltage	V _{ih}			2.0		V	4.5V < V _{LOGIC} < 5.5V
				0.8 V _{LOGIC}			3.0V < V _{LOGIC} < 4.5V
LOW level input voltage	V _{il}				0.8	V	4.5V < V _{LOGIC} < 5.5V
					0.2 V _{LOGIC}		3.0V < V _{LOGIC} < 4.5V
HIGH level output voltage	V _{oh}			2.0		V	V _{LOGIC} = 4.5V, I _{oh} = -40μA
				0.8 V _{LOGIC}			3.0V < V _{LOGIC} < 4.5V
LOW level output voltage	V _{ol}				0.4	V	V _{LOGIC} = 4.5V, I _{oh} = -40μA
					0.2 V _{LOGIC}		3.0V < V _{LOGIC} < 4.5V
Thermal Resistance	R _{θJ-P}	70				°C/W	IC junction to pin

Notes:

- In SLEEP mode, the internal oscillator and reference current for LED drivers are off.
- Average peak pixel current is measured at the maximum drive current set by Control Register 0. Individual pixels may exceed this value.

Optical Characteristics at 25 ± 1 °C ^[1]

V_{LED} = 5.0V, 100% Peak Current, 100% Pulse Width

Display Color	Luminous Intensity per LED ^[2] Character Average (μcd)		Peak Wavelength	Dominant Wavelength
	Min	Typical	λ _{Peak} (nm) Typ.	λ _d ^[3] (nm) Typ.
Blue	29	170	456	460

Notes:

- Refers to the initial case temperature of the device immediately prior to measurement.
- Measured with all LEDs illuminated in a digit.
- Dominant wavelength, λ_d, is derived from the CIE Chromaticity diagram and represents the single wavelength which defines the perceived LED color.

Electrical Description

Pin Function Description

$\overline{\text{RESET}}$ ($\overline{\text{RST}}$)	Sets Control Register bits to logic low. The Dot Register contents are unaffected by the Reset pin. (logic low = reset; logic high = normal operation)
DATA IN (D_{IN})	Serial Data input for Dot or Control Register data. Data is entered on the rising edge of the Clock input.
DATA OUT (D_{OUT})	Serial Data out put for Dot or Control Register data. This pin is used for cascading multiple displays.
CLOCK (CLK)	Clock input for writing Dot or Control Register data. When $\overline{\text{Chip Enable}}$ is logic low, data is entered on the rising Clock edge.
REGISTER SELECT (RS)	Selects Dot Register (RS = logic low) or Control Register (RS = logic high) as the destination for serial data entry. The logic level of RS is latched on the falling edge of the Chip Enable input.
$\overline{\text{CHIP ENABLE}}$ ($\overline{\text{CE}}$)	This input must be a logic low to write data to the display. When $\overline{\text{CE}}$ returns to logic high and CLK is logic low, data is latched to either the LED output drivers or a Control Register.
OSCILLATOR SELECT	Selects either an internal or external display oscillator source. (SEL) (logic low = External Display Oscillator; logic high = Internal Display Oscillator).
OSCILLATOR (OSC)	Output for the Internal Display Oscillator (SEL = logic high) or input for an External Display Oscillator (SEL = logic low).
BLANK (BL)	Blanks the display when logic high. May be modulated for brightness control.
GND_{LED}	Ground for LED drivers
$\text{GND}_{\text{LOGIC}}$	Ground for logic.
V_{LED}	Positive supply for LED drivers
V_{LOGIC}	Positive supply for logic.

AC Timing Characteristics Over Temperature Range (-40 to +85°C)

Timing Diagram Ref. Number	Description	Symbol	4.5V < V _{LOGIC} < 5.5V		V _{LOGIC} = 3V		Units
			Min	Max	Min	Max	
1	Register Select Setup Time to $\overline{\text{Chip Enable}}$	t _{rss}	10		10		ns
2	Register Select Hold Time to $\overline{\text{Chip Enable}}$	t _{rsh}	10		10		ns
3	Rising Clock Edge to Falling $\overline{\text{Chip Enable}}$ Edge	t _{clkce}	20		20		ns
4	$\overline{\text{Chip Enable}}$ Setup Time to Rising Clock Edge	t _{ces}	35		55		ns
5	$\overline{\text{Chip Enable}}$ Hold Time to Rising Clock Edge	t _{ceh}	20		20		ns
6	Data Setup Time to Rising Clock Edge	t _{ds}	10		10		ns
7	Data Hold Time after Rising Clock Edge	t _{dh}	10		10		ns
8	Rising Clock Edge to DOUT ^[1]	t _{dout}	10	40	10	65	ns
9	Propagation Delay DIN to DOUT Simultaneous Mode for one IC ^[1,2]	t _{doutp}		18		30	ns
10	$\overline{\text{CE}}$ Falling Edge to DOUT Valid	t _{cedo}		25		45	ns
11	Clock High Time	t _{clkh}	80		100		ns
12	Clock Low Time	t _{ckl}	80		100		ns
	Reset Low Time	t _{rstl}	50		50		ns
	Clock Frequency	F _{cyc}		5		4	MHz
	Internal Display Oscillator Frequency	F _{inosc}	80	210	80	210	kHz
	Internal Refresh Frequency	F _{rf}	150	410	150	410	Hz
	External Display Oscillator Frequency	F _{exosc}					
	Prescaler = 1		51.2	1000	51.2	1000	kHz-
	Prescaler = 8		410	8000	410	8000	kHz

Notes:

1. Timing specifications increase 0.3ns per pf of capacitive loading above 15pF.
2. This parameter is valid for Simultaneous Mode data entry of the Control Register.

Display Overview

The HCMS-281x blue LED displays are driven by on-board CMOS ICs. The LEDs are configured as 5x7 font characters and are driven in groups of 4 characters per IC. Each IC consists of a 160-bit shift register (the Dot Register), two 7-bit Control Words, and refresh circuitry. The Dot Register contents are mapped on a one-to-one basis to the display. Thus, an individual Dot Register bit uniquely controls a single LED.

8-character displays have two ICs that are cascaded. The Data Out line of the first IC is internally connected to the Data In line of the second IC forming a 320-bit Dot Register. The display's other control and power lines are connected directly to both ICs.

Reset

Reset initializes the Control Register (sets all Control Register bits to logic low) and places the display in the sleep mode. The $\overline{\text{Reset}}$ pin should be connected to the system power on reset circuit. The Dot Registers are not cleared upon power-on or by $\overline{\text{Reset}}$. After power-on, the Dot Register contents are random; however, $\overline{\text{Reset}}$ will put the display in sleep mode, thereby blanking the LEDs. The Control Register and the Control Words are cleared to all zeros by $\overline{\text{Reset}}$.

To operate the display after being $\overline{\text{Reset}}$, load the Dot Register with logic lows. Then load Control Word 0 with the desired brightness level and set the sleep mode bit to logic high.

Dot Register

The Dot Register holds the pattern to be displayed by the LEDs. Data is loaded into the Dot Register according to the procedure shown in Table 1 and Figure 2.

First RS is brought low, then \overline{CE} is brought low. Next, each successive rising CLK edge will shift in the data at the DIN pin. Loading a logic high will turn the corresponding LED on; a logic low turns the LED off. When all 160 bits have been loaded (or 320 bits in an 8-digit display), \overline{CE} is brought to logic high.

When CLK is next brought to logic low, new data is latched into the display dot drivers. Loading data into the Dot Register takes place while the previous data is displayed and eliminates the need to blank the display while loading data.

Table 1. Register Truth Table

Function	CLK	CE	RS
Select Dot Register	Not Rising	Falling	
Load Dot Register DIN = HIGH, LED = "ON" DIN = LOW, LED = "OFF"	Rising	L	X
Copy Data from Dot Register to Dot Latch	L	H	X
Select Control Register	Not Rising	Falling	H
Load Control Register ^[1,3]	Rising	L	X
Latch Data to Control Word ^[2]	L	H	X

Notes:

1. Bit D₀ of Control Word 1 must have been precisely set to Low for serial mode or High for simultaneous mode.
2. Selection of Control Word 1 or Control Word 0 is set by D₇ of the Control Shift Register. The unselected control word retains its previous value.
3. Control Word data is loaded Most Significant Bit (D₇) first.

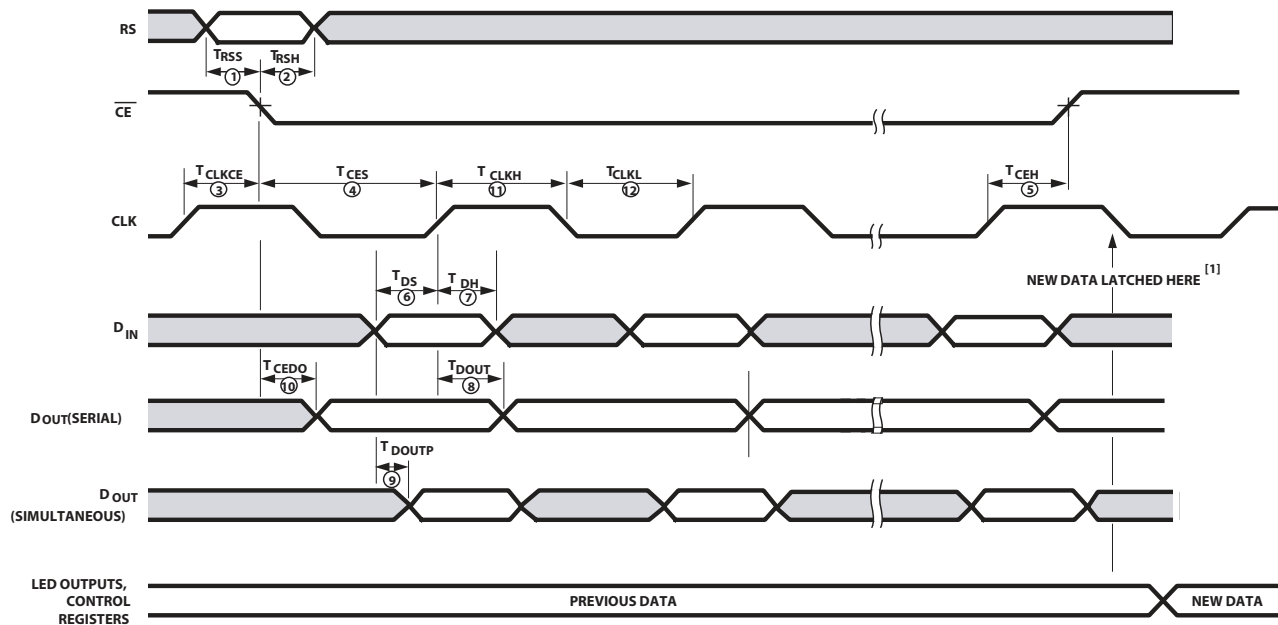

NOTE:
1. DATA IS COPIED TO THE CONTROL REGISTER OR THE DOT LATCH AND LED OUTPUTS WHEN \overline{CE} IS HIGH AND CLK IS LOW.

Figure 2. Write Cycle Timing Diagram

Pixel Map

In a 4-character display, the 160-bits are arranged as 20 columns by 8 rows. This array can be conceptualized as four 5x8 dot matrix character locations, but only 7 of the 8 rows have LEDs (see Figure 3 & 4). The bottom row (row 0) is not used. Thus, latch location 0 is never displayed. Column 0 controls the left-most column. Data from Dot Latch locations 0-7 determine whether or not pixels in Column 0 are turned-on or turned off. Therefore, the lower left pixel is turned-on when a logic high is stored in Dot Latch location 3. Characters are loaded in serially, with the left-most character being loaded first and the right-most character being loaded last. By loading one character at a time and latching the data before loading the next character, the figures will appear to scroll from right to left.

Control Register

The Control Register allows software modification of the IC's operation and consists of two independent 7-bit control words. Bit D₇ in the shift register selects one of the two 7-bit control words. Control Word 0 performs pulse width modulation brightness control, peak pixel current brightness control, and sleep mode. Control Word 1 sets serial/simultaneous data out mode, and external oscillator prescaler. Each function is independent of others.

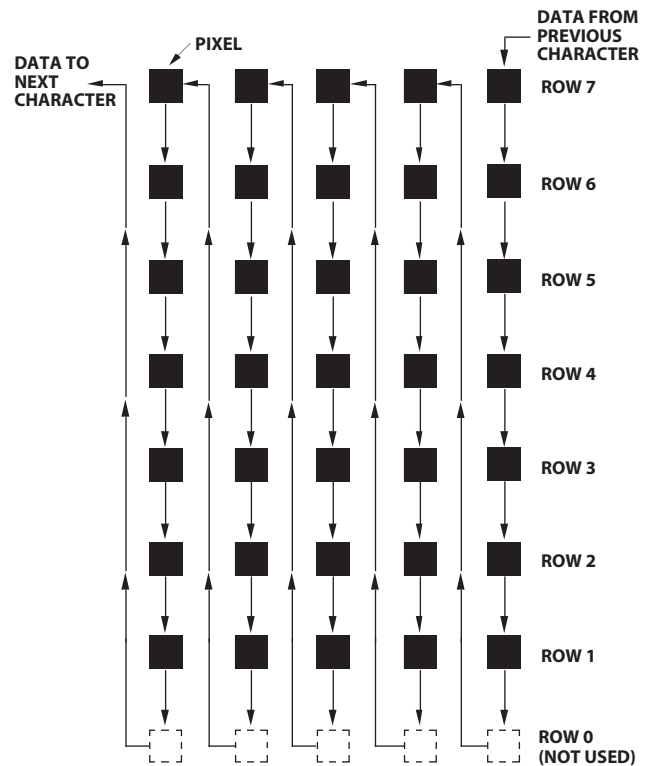

Figure 3. Pixel Map

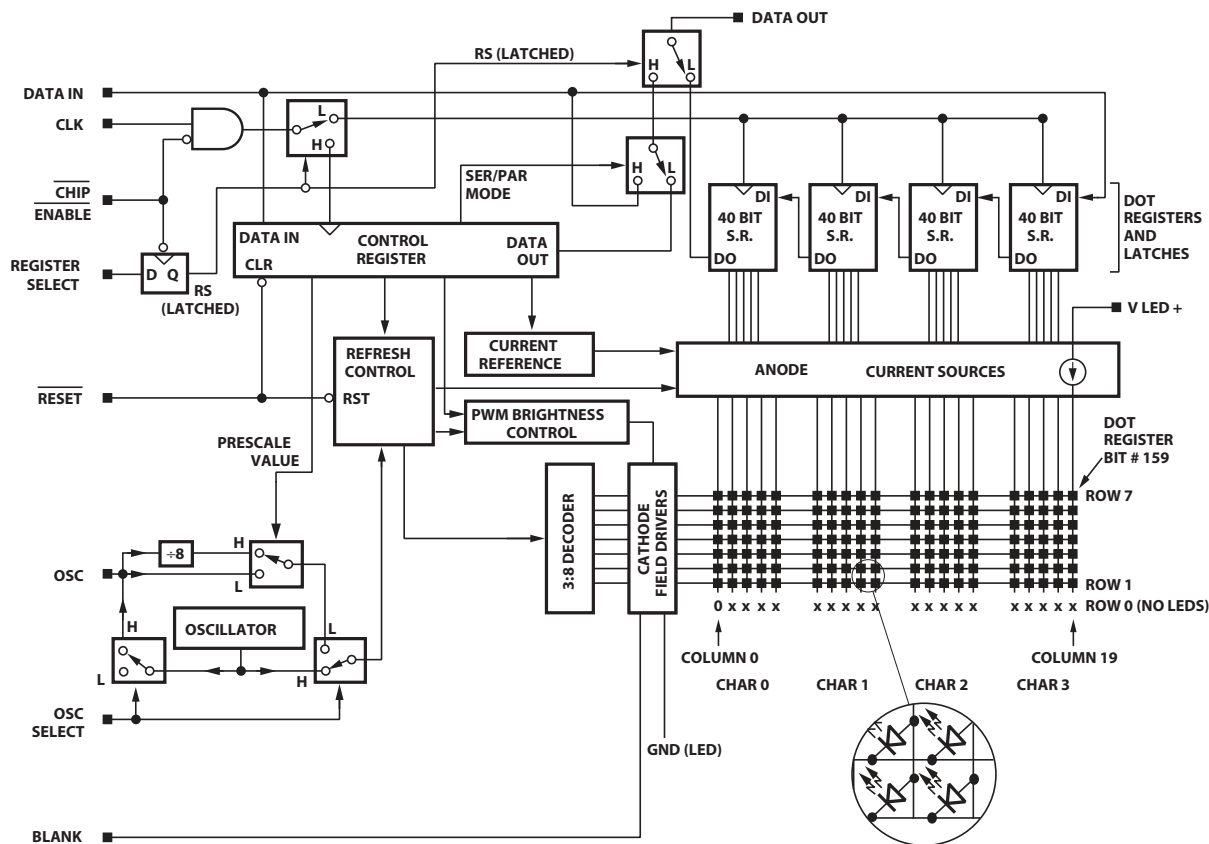

Figure 4. Block diagram

Control Register Data Loading

Data is loaded into the Control Register, MSB first, according to the procedure shown in Table 1 and Figure 2. First, RS is brought to logic high and then \overline{CE} is brought to logic low. Next, each successive rising CLK edge will shift in the data on the DIN pin. Finally, when 8 bits have been loaded, the \overline{CE} line is brought to logic high. When CLK goes to logic low, new data is copied into the selected control word. Loading data into the Control Register takes place while the previous control word configures the displays.

Control Word 0

Loading the Control Register with $D_7 = \text{Logic Low}$ selects Control Word 0 (see Table 2). Bits D_0 - D_3 adjust the display brightness by pulse width modulating the LED on time, while Bits D_4 - D_5 adjust the display brightness by changing the peak pixel current. Bit D_6 selects normal operation or sleep mode.

ing the peak pixel current. Bit D_6 selects normal operation or sleep mode.

Sleep mode (Control Word 0, bit $D_6 = \text{Low}$) turns off the Internal Display Oscillator and the LED pixel drivers. This mode is used when the IC needs to be powered up, but does not need to be active. Current draw in sleep mode is nearly zero. Data in the Dot Register and Control Words are retained during sleep mode.

Control Word 1

Loading the Control Register with $D_7 = \text{Logic High}$ selects Control Word 1. This control word performs two functions: serial/simultaneous data out mode and external oscillator prescale select (see Table 2).

Table 2. Control Shift Register

CONTROL WORD 0												
L	D_6	D_5	D_4	D_3	D_2	D_1	D_0					
↑ Bit D_7 Set Low to Select Control Word 0			PWM Brightness Control				On-Time Oscillator Cycles	Duty Factor (%)	Relative Brightness (%)			
			L	L	L	L				0	0	0
			L	L	L	H				1	0.2	1.7
			L	L	H	L				2	0.4	3.3
			L	L	H	H				3	0.6	5.0
			L	H	L	L				4	0.8	6.7
			L	H	L	H				5	1.0	8.3
			L	H	H	L				7	1.4	11.7
			L	H	H	H				9	1.8	15
			H	L	L	L				11	2.1	18
			H	L	L	H				14	2.7	23
			H	L	H	L				18	3.5	30
			H	L	H	H				22	4.3	37
			H	H	L	L				28	5.5	47
			H	H	L	H				36	7.0	60
			H	H	H	L				48	9.4	80
H	H	H	H	60	11.7	100						
SLEEP MODE		Peak Current Brightness Control		Typical Peak Pixel Current (mA)		Relative Full Scale Current (Relative Brightness, %)						
		H	L	4.0		31						
		L	H	6.4		50						
		L	L	9.3		73 (Default at Power Up)						
		H	H	12.8		100						

L - DISABLES INTERNAL OSCILLATOR-DISPLAY BLANK
H - NORMAL OPERATION

CONTROL WORD 1							
H	L	L	L	L	L	D_1	D_0
↑ Bit D_7 Set High to Select Control Word 1						External Display Oscillator Prescaler L - Oscillator Freq \div 1 H - Oscillator Freq \div 8	Serial/Simultaneous Data Out L - D_{out} holds contents of Bit D_7 H - D_{out} is functionally tied to D_{in}

Serial/Simultaneous Data Output D₀

Bit D₀ of control word 1 is used to switch the mode of D_{OUT} between serial and simultaneous data entry during Control Register writes. The default mode (logic low) is the serial D_{OUT} mode. In serial mode, D_{OUT} is connected to the last bit D₇ of the Control Shift Register.

Storing logic high to bit D₀ changes D_{OUT} to simultaneous mode, which affects the Control Register only. In simultaneous mode, D_{OUT} is logically connected to D_{IN}. This arrangement allows multiple ICs to have their Control Registers written to simultaneously. For example, for n ICs in the serial mode, n * 8 clock pulses to load the same data in all Control Registers. The propagation delay from the first IC to the last is n * t_{DOUTP}.

External Oscillator Prescaler Bit D1

Bit D1 of Control Word 1 is used to scale the frequency of an external Display Oscillator. When this bit is logic low, the external Display Oscillator directly sets the internal display clock rate. When this bit is a logic high, the external oscillator is divided by 8. This scaled frequency then sets the internal display clock rate. It takes 512 cycles of the display clock (or 8 x 512 = 4096 cycles of an external clock with the divide by 8 prescaler) to completely refresh the display once. Using the prescaler bit allows the designer to use a higher external oscillator frequency without extra circuitry.

This bit has no affect on the internal Display Oscillator Frequency.

Bits D2-D6

These bits must always be programmed to logic low.

Cascaded ICs

Figure 5 shows how two ICs are connected within an HCMS-281x display. The first IC controls the four left-most characters and the second IC controls the four right-most characters. The Dot Registers are connected in series to form a 320-bit dot shift register. The location of pixel 0 has not changed. However, Dot Shift Register bit 0 of IC2 becomes bit 160 of the 320-bit dot shift register.

The Control Registers of the two ICs are independent of each other. This means that to adjust the display brightness the same control word must be entered into both ICs, unless the Control Registers are set to simultaneous mode.

Longer character string systems can be built by cascading multiple displays together. This is accomplished by creating a five line bus. This bus consists of \overline{CE} , RS, BL, Reset, and CLK. The display pins are connected to the corresponding bus line. Thus, all \overline{CE} pins are connected to the \overline{CE} bus line. Similarly, bus lines for RS, BL, Reset, and CLK are created. Then D_{IN} is connected to the right-most display. D_{OUT} from this display is connected to the next display. The left-most display receives its D_{IN} from the D_{OUT} of the display to its right. D_{OUT} from the left-most display is not used.

Each display may be set to use its internal oscillator, or the displays may be synchronized by setting up one display as the master and the others as slaves. The slaves are set to receive their oscillator input from the master's oscillator output.

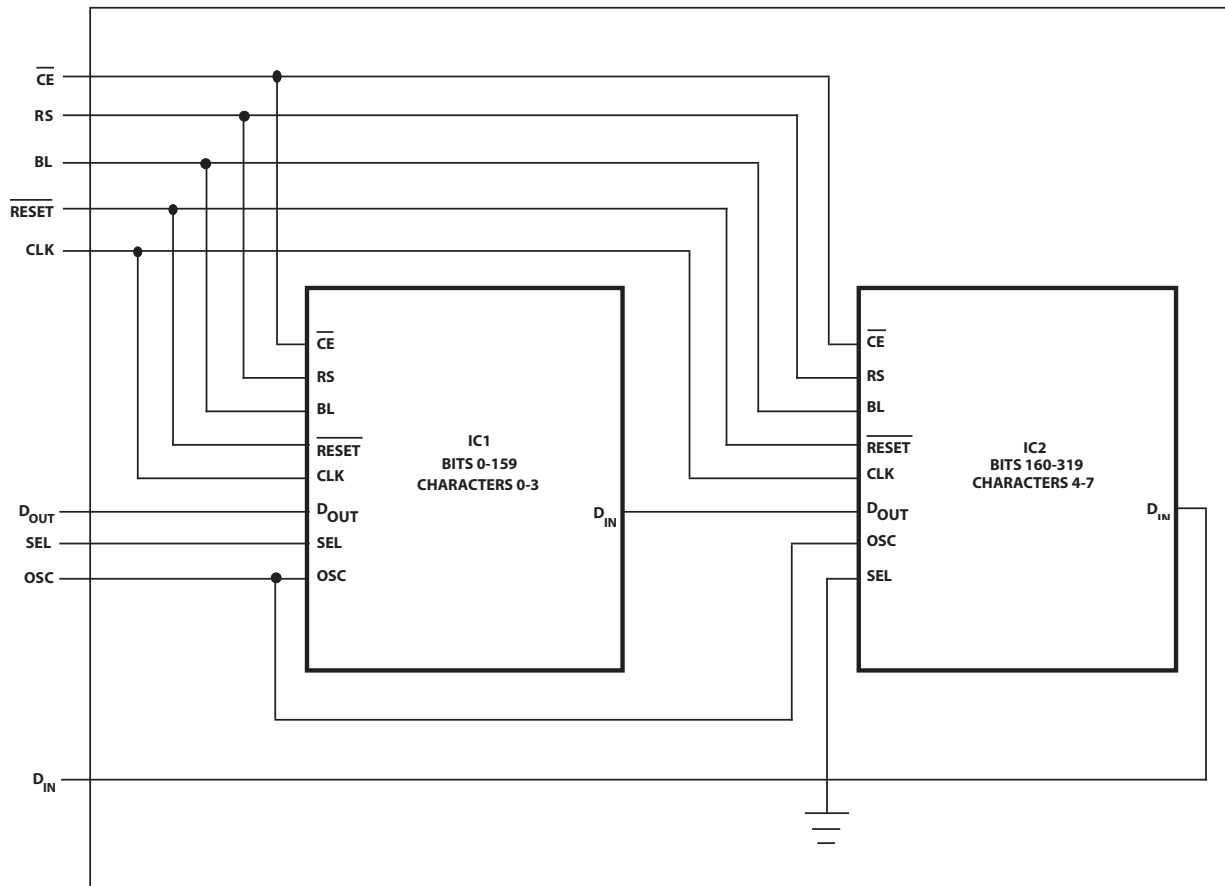

Figure 5. Cascaded ICs.

Appendix A. Thermal Considerations

The display IC has a maximum junction temperature of 150°C. The IC junction temperature can be calculated with Equation 1 below.

A typical value for $R\theta_{JA}$ is 100°C/W. This value is typical for a display mounted in a socket and covered with a plastic filter. The socket is soldered to a .062 in. thick PCB with .020 inch wide, one ounce copper traces. PD can be calculated as Equation 2 below.

Figure 6 shows how to derate the power of one IC versus ambient temperature. Operation at high ambient temperatures may require the power per IC to be reduced. The power consumption can be reduced by changing either the N , I_{PIXEL} , $Osc\ cyc$ or V_{LED} . Changing V_{LOGIC} has very little impact on the power consumption.

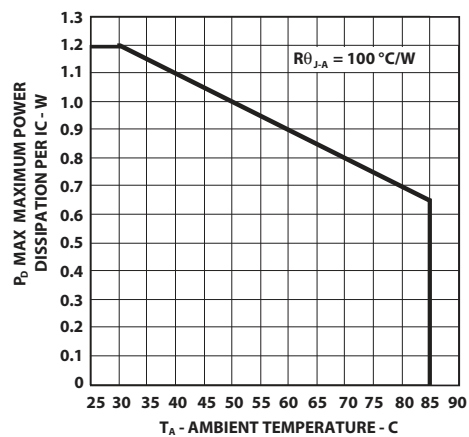

Figure 6. Maximum power dissipation per IC versus ambient temperature.

Appendix B. Electrical Considerations

Current Calculations

The peak and average display current requirements have a significant impact on power supply selection. The maximum peak current is calculated with Equation 3 below.

The average current required by the display can be calculated with Equation 4 below.

The power supply has to be able to supply I_{PEAK} transients and supply I_{LED} (AVG) continuously. The range on V_{LED} allows noise on this supply without significantly changing the display brightness.

V_{LOGIC} and V_{LED} Considerations

The display uses two independent electrical systems. One system is used to power the display's logic and the other to power the display's LEDs. These two systems keep the logic supply clean.

Separate electrical systems allow the voltage applied to V_{LED} and V_{LOGIC} to be varied independently. Thus, V_{LED} can vary from 0 to 5.5V without affecting either the Dot or the Control Registers. V_{LED} can be varied between 4.0 to 5.5 V without any noticeable variation in light output. However, operating V_{LED} below 4.5 V may cause objectionable mismatch between the pixels and is not recommended. Dimming the display by pulse width modulating V_{LED} is also not recommended.

V_{LOGIC} can vary from 3.0 to 5.5 V without affecting either the displayed message or the display intensity. However, operation below 4.5 V will change the timing and logic levels and operation below 3 V may cause the Dot and Control Registers to be altered

The logic ground is internally connected to the LED ground by a substrate diode. This diode becomes forward biased and conducts when the logic ground is 0.4 V greater than the LED ground. The LED ground and the logic ground should be connected to a common ground, which can withstand the current introduced by the switching LED drivers. When separate ground connections are used, the LED ground can vary from -0.3 V to +0.3 V with respect to the logic ground. Voltages below -0.3 V can cause all the dots to be ON. Voltage above +0.3 V can cause dimming and dot mismatch.

Using a decoupling capacitor between the power supply and ground will help prevent any supply noise in the frequency range greater than that of the functioning display from interfering with the display's internal circuitry. The value of the capacitor depends on the series resistance from the ground back to the power supply and the range of frequencies that need to be suppressed. It is also advantageous to use the largest ground plane possible.

Equation 1:

$$T_{JMAX} = T_A + P_D * R_{\theta JA}$$

Where:

T_{JMAX} = maximum IC junction temperature

T_A = ambient temperature surrounding the display

$R_{\theta JA}$ = thermal resistance from the IC junction to ambient

P_D = power dissipated by the IC

Equation 2:

$$P_D = (N * I_{PIXEL} * \text{Duty Factor} * V_{LED}) + I_{LOGIC} * V_{LOGIC}$$

Where:

P_D = total power dissipation

N = number of pixels on (maximum 4 char * 5 * 7 = 140)

I_{PIXEL} = peak pixel current.

Duty Factor = $1/8 * \text{Osc cyc}/64$

Osc cyc = number of ON oscillator cycles per row

I_{LOGIC} = IC logic current

V_{LOGIC} = logic supply voltage

Equation 3:

$$I_{PEAK} = M * 20 * I_{PIXEL}$$

Where:

I_{PEAK} = maximum instantaneous peak current for the display

M = number of ICs in the system

20 = maximum number of LEDs on per IC

I_{PIXEL} = peak current for one LED

Equation 4:

$$I_{LED} \text{ (AVG)} = N * I_{PIXEL} * 1/8 * (\text{oscillator cycles})/64$$

(see Variable Definitions above)

Electrostatic Discharge

The inputs to the ICs are protected against static discharge and input current latchup. However, for best results, standard CMOS handling precautions should be used. Before use, the HCMS-281x should be stored in antistatic tubes or in conductive material. During assembly, a grounded conductive work area should be used and assembly personnel should wear conductive wrist straps. Lab coats made of synthetic material should be avoided since they are prone to static buildup. Input current latchup is caused when the CMOS inputs are subjected to either a voltage below ground ($V_{IN} < \text{ground}$) or to a voltage higher than V_{LOGIC} ($V_{IN} > V_{LOGIC}$) and when a high current is forced into the input. To prevent input current latchup and ESD damage, unused inputs should be connected to either ground or V_{LOGIC} . Voltages should not be applied to the inputs until V_{LOGIC} has been applied to the display.

Appendix C. Oscillator

The oscillator provides the internal refresh circuitry with a signal that is used to synchronize the columns and rows. This ensures that the right data is in the dot drivers for that row. This signal can be supplied from either an external source or the internal source. A display refresh rate of 100 Hz or faster ensures flicker-free operation. Thus for an external oscillator the frequency should be greater than or equal to $512 \times 100 \text{ Hz} = 51.2 \text{ kHz}$. Operation above 1 MHz without the prescaler or 8 MHz with the prescaler may cause noticeable pixel to pixel mismatch.

Appendix D. Refresh Circuitry

This display driver consists of 20 one-of-eight column decoders and 20 constant current sources, 1 one-of-eight row decoder and eight row sinks, a pulse width modulation control block, a peak current control block, and the circuit to refresh the LEDs. The refresh counters and oscillator are used to synchronize the columns and rows. The 160 bits are organized as 20 columns by 8 rows. The IC illuminates the display by sequentially turning ON each of the 8 row-drivers. To refresh the display once takes 512 oscillator cycles. Because there are eight row drivers, each row driver is selected for 64 ($512/8$) oscillator cycles. Four cycles are used to briefly blank the display before the following row is switched on. Thus, each row is ON for 60 oscillator cycles out of a possible 64. This corresponds to the maximum LED on time.

Appendix E. Display Brightness

Two ways have been shown to control the brightness of this LED display: setting the peak current and setting the duty factor. Both values are set in Control Word 0. To compute the resulting display brightness when both PWM and peak current control are used, simply multiply the two relative brightness factors. For example, if Control Register 0 holds the word 1001101, the peak current is 73% of full scale (BIT D₅ = L, BIT D₄ = L) and the PWM is set to 60% duty factor (BIT D₃ = H, BIT D₂ = H, BIT D₁ = L, BIT D₀ = H). The resulting brightness is 44% ($.73 \times .60 = .44$) of full scale. The temperature of the display will also affect the LED brightness as shown in Figure 8. The temperature of the display will also affect the LED brightness as shown in Figure 7.

Appendix F. Reference Material

Application Note 1027: Soldering LED Components

Application Note 1015: Contrast Enhancement Techniques for LED Displays

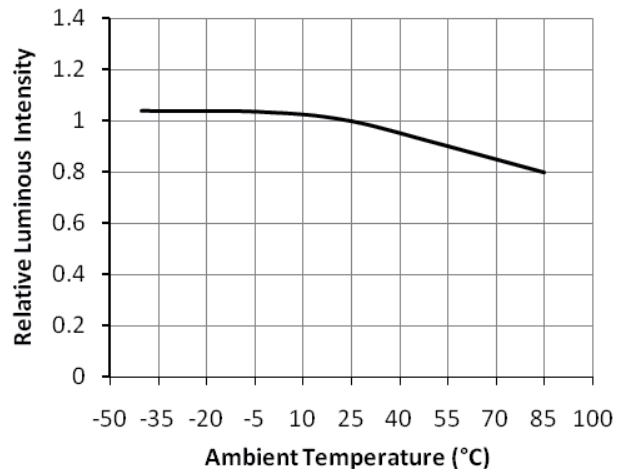

Figure 7. Relative luminous intensity versus ambient temperature.

For product information and a complete list of distributors, please go to our web site:

www.avagotech.com

Avago, Avago Technologies, and the A logo are trademarks of Avago Technologies in the United States and other countries. Data subject to change. Copyright © 2005-2010 Avago Technologies. All rights reserved. AV02-2558EN - June 29, 2010

Avago
TECHNOLOGIES