

STRAIGHT PLUG CRIMP OR SOLDER TYPE

R125.077.000

CABLE 5/50 S.TR.

Series : SMA

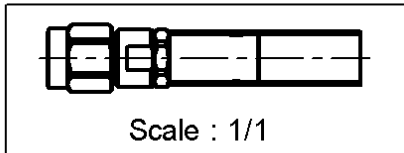
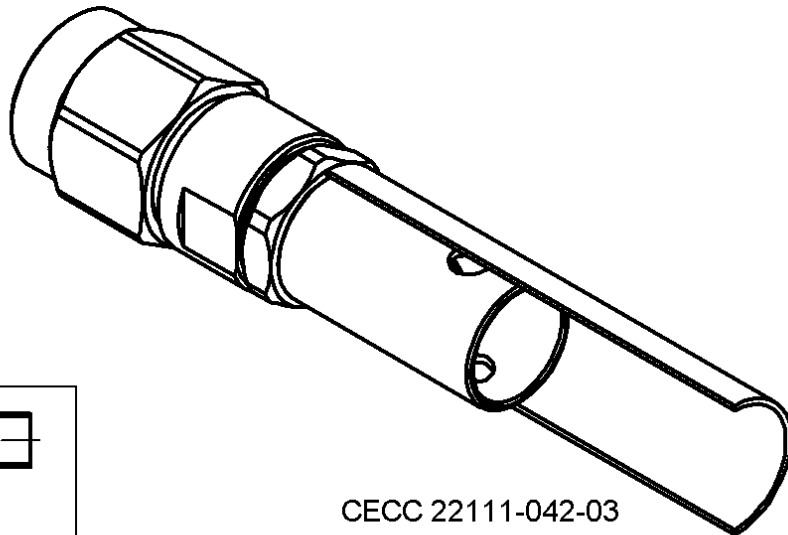
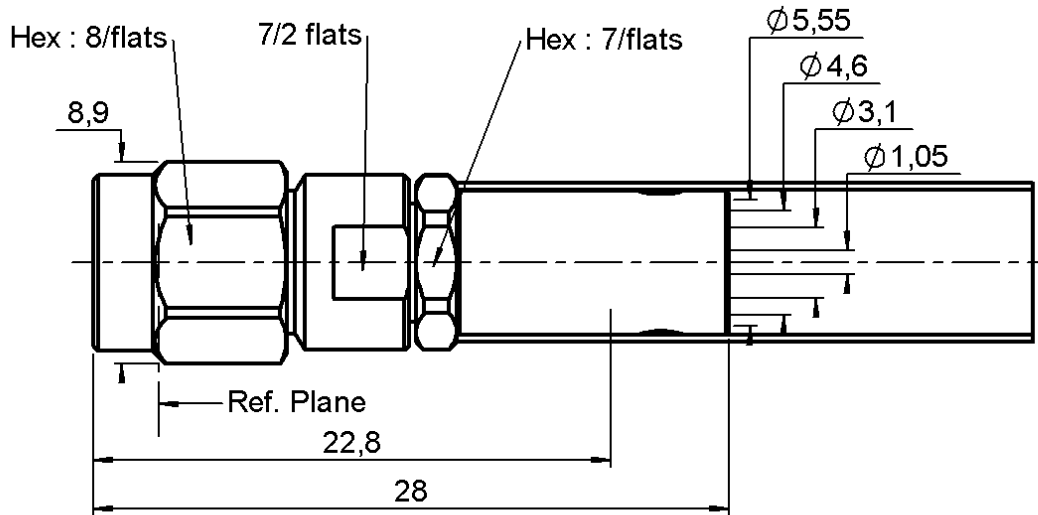

CECC 22111-042-03

All dimensions are in mm.



COMPONENTS	MATERIALS	PLATINGS (μm)
BODY	STAINLESS STEEL	GOLD 0.5 OVER NICKEL 2
CENTER CONTACT	BRASS	GOLD 1.3 OVER NICKEL 2
OUTER CONTACT	-	-
INSULATOR	PTFE	-
GASKET	SILICONE RUBBER	-
OTHERS PARTS	BRASS	GOLD 0.5 OVER NICKEL 2
-	-	-
-	-	-

Issue : 0122 F

In the effort to improve our products, we reserve the right to make changes judged to be necessary.



STRAIGHT PLUG CRIMP OR SOLDER TYPE

R125.077.000

CABLE 5/50 S.TR.

Series : SMA

PACKAGING

Standard	Unit	Other
100	'W' option	Contact us

SPECIFICATION

ELECTRICAL CHARACTERISTICS

Impedance		50 Ω
Frequency		0-12.4 GHz
VSWR	1.15 +	0.010 x F(GHz) Maxi
Insertion loss		0.06 √F(GHz) dB Maxi
RF leakage	- (60 - F(GHz)) dB Maxi
Voltage rating		335 Veff Maxi
Dielectric withstanding voltage		1000 Veff mini
Insulation resistance		5000 MΩ mini

CABLE ASSEMBLY

Stripping	a	b	c	d	e	f
mm	3.50	7.00	13.5	0.00	10.0	0.00

Assembly instruction : **Crimp 10**

Recommended cable(s)
 RG 58
 KX 15
 RG 141

Cable retention
 - pull off **180** N mini
 - torque **NA** N.cm

MECHANICAL CHARACTERISTICS

Center contact retention		
Axial force – Mating end	27	N mini
Axial force – Opposite end	27	N mini
Torque	NA	N.cm mini

TOOLING

Part Number	Description	Hexagon
.	.	.
R282.223.000	CRIMPING TOOL	5.40
R282.235.011	CRIMPING DIES	5.40
R282.293.000	CRIMPING TOOL	-

Recommended torque		
Mating	100	N.cm
Panel nut	NA	N.cm
Clamp nut	100	N.cm
A/F clamp nut	7.000	mm

Mating life	500	Cycles mini
Weight	5.356	g

OTHERS CHARACTERISTICS

-

ENVIRONMENTAL

Operating temperature	-65/+165	° C
Hermetic seal	NA	Atm.cm3/s
Panel leakage	NA	

Issue : 0122 F

In the effort to improve our products, we reserve the right to make changes judged to be necessary.

