

LOC		DIST		REVISIONS			
P	LTN	DESCRIPTION	DATE	DWN	APVD		
G		REVISED PER ECR-21-100678	08APR2021	SS	VS		

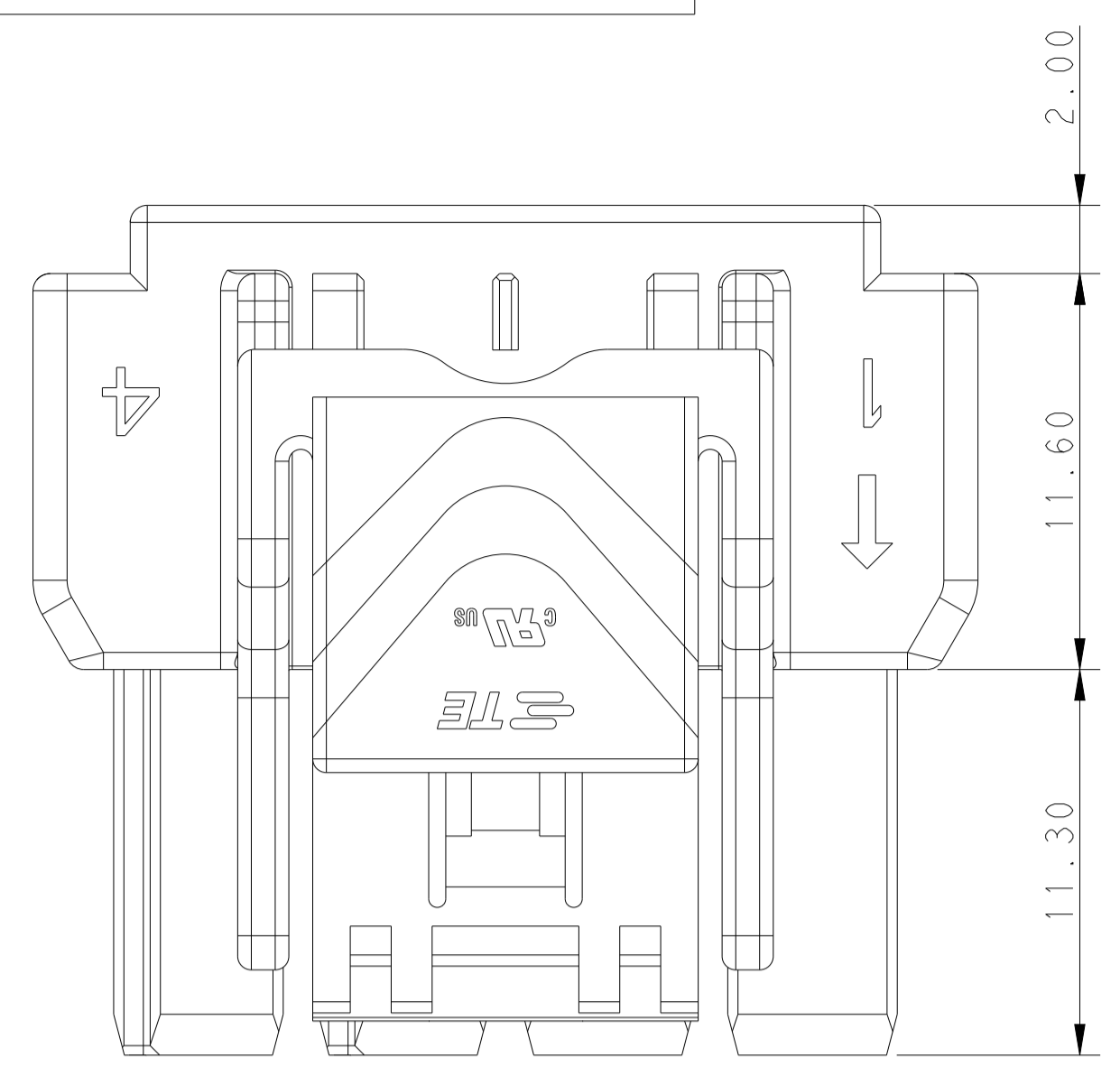

POS.	DIM. A	DIM. B
1*5	33.7	28.0
1*4	27.7	22.0
1*3	21.7	16.0
1*2	15.7	10.0

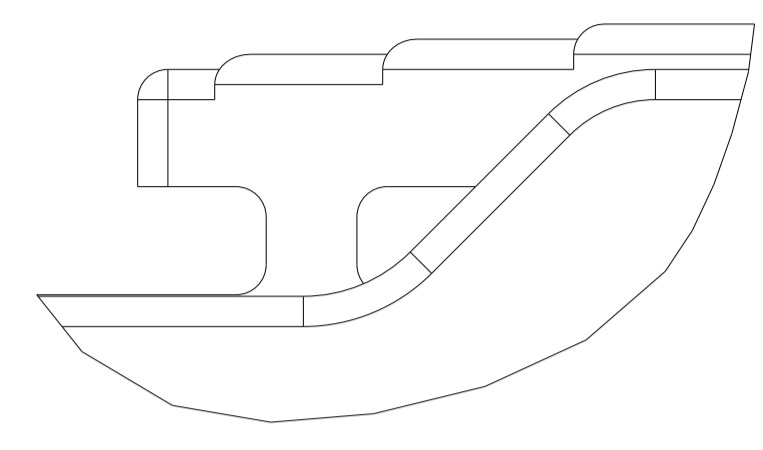

LEVEL 2 LATCH DESIGN

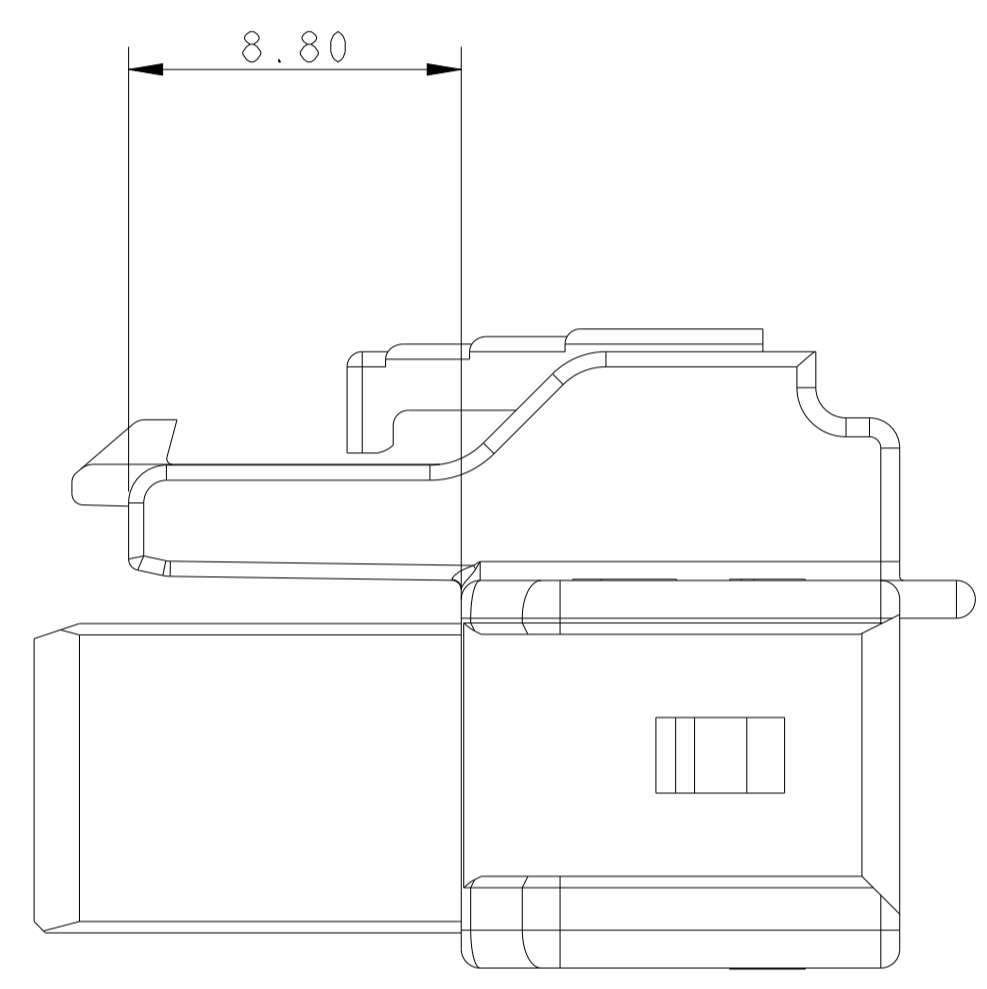
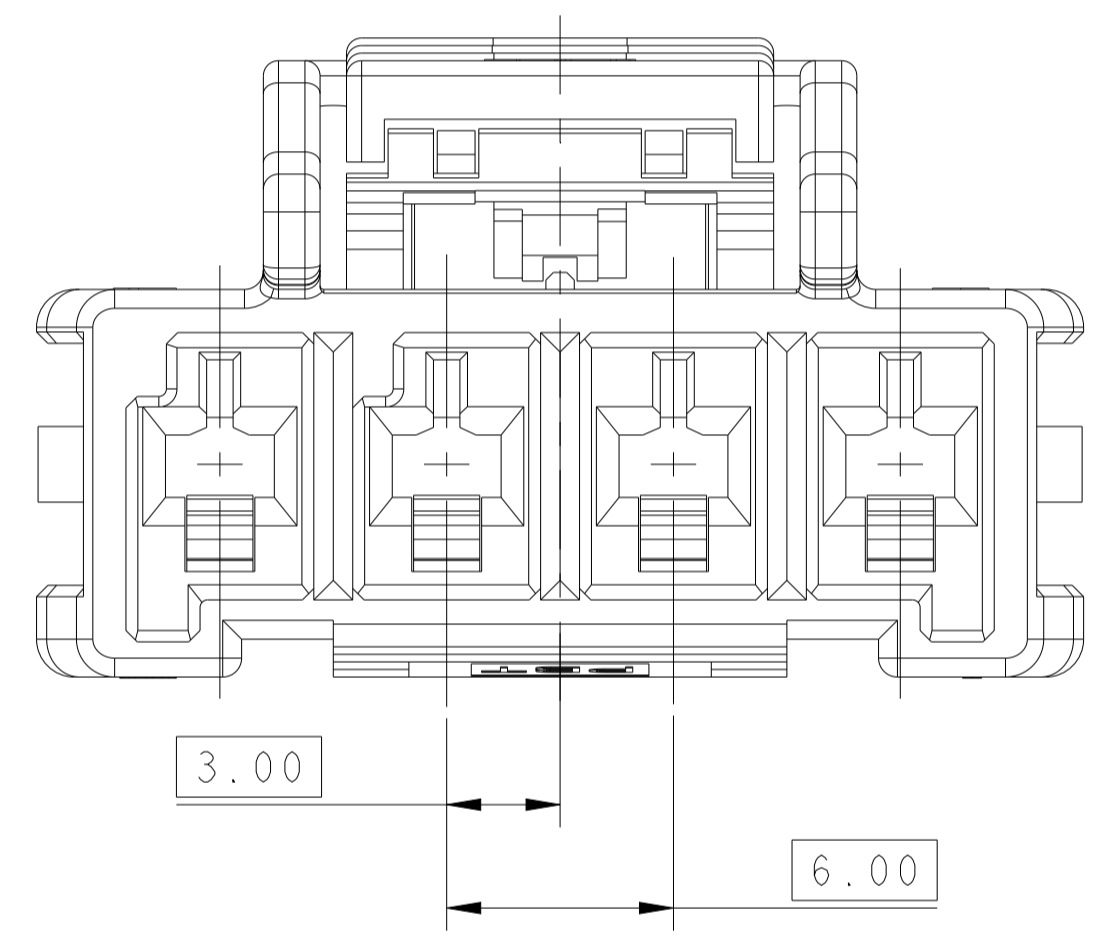

LEVEL 1 LATCH DESIGN

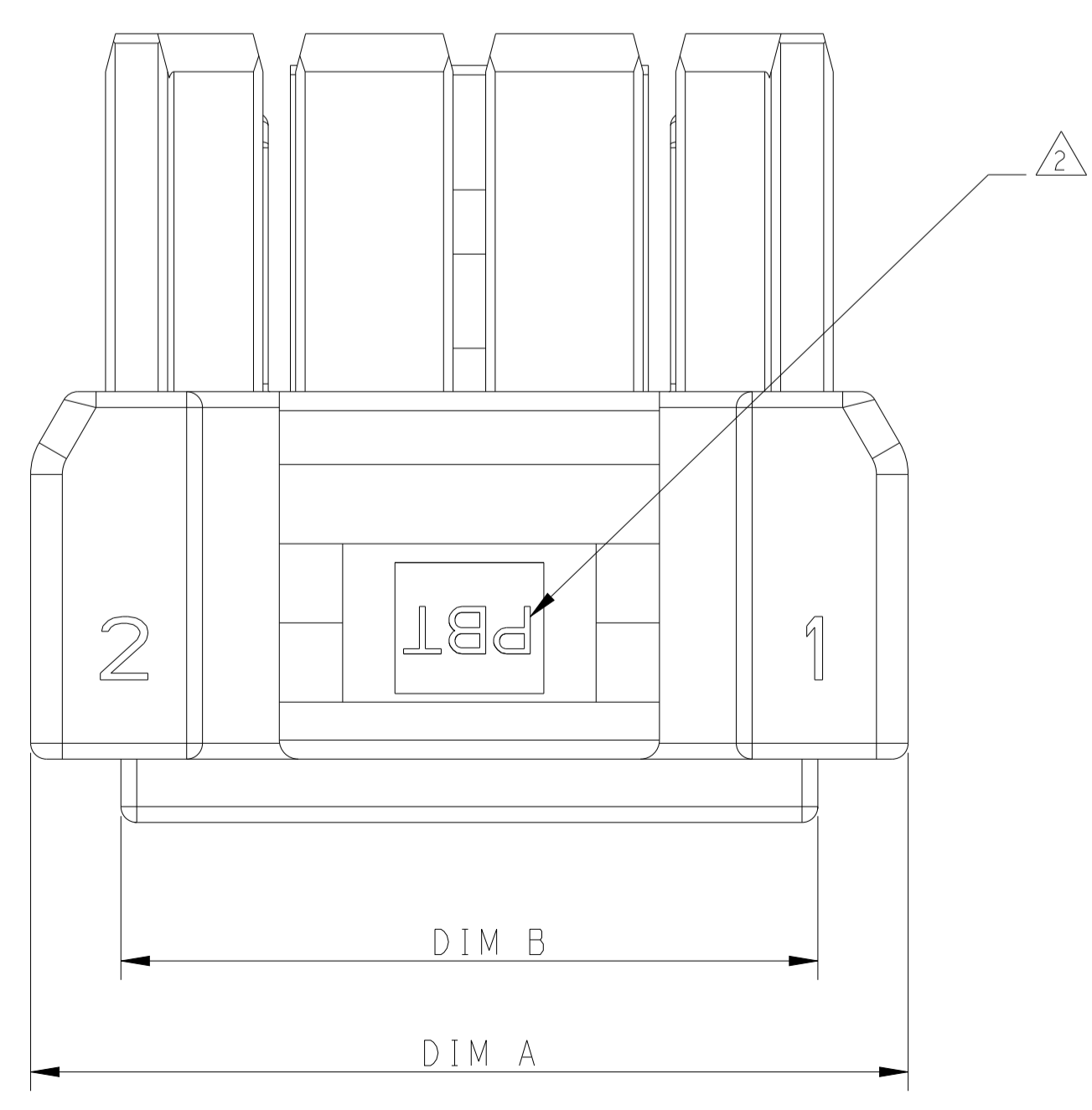
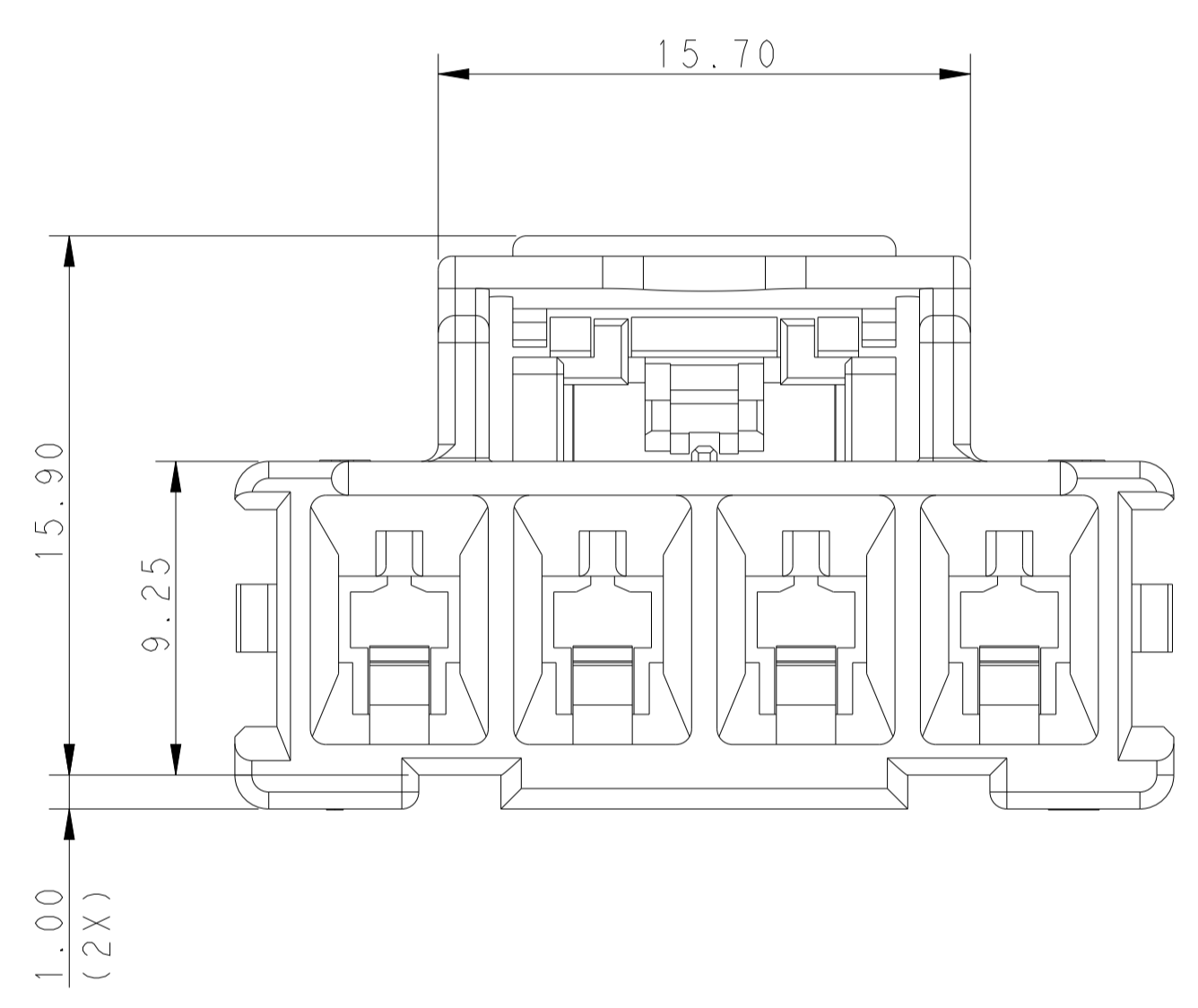

- ▲ MATERIAL:
 LEVEL 1: PBT GLASS FILLED, STANDARD TEMPERATURE 105°C
 KEY A: NATURAL; KEY B: PURPLE; KEY C: BLUE; KEY D: YELLOW
 LEVEL 2: NYLON (PA 66), HIGH TEMPERATURE 150°C
 KEY A: LIGHT GREY; KEY B: RED; KEY C: BLACK; KEY D: NATURAL
- ▲ MATERIAL MARK:
 LEVEL 1: PBT, LEVEL 2: HDT
- 3 APPLICABLE CONTACT P/N
 RECEPTACLE CONTACT: 1971237/1971779/81/83/85/87-* , 2238066-*
- 4 MATING CONN, P/N
 CAP HSG: *-1971772-* AND HEADERS: *-1969688-*, *-1969694-*, *-1971777-*
- 5 FLAMMABILITY RATED UL94 V-0
- ▲ GLOW WIRE COMPLIANT IN ACCORDANCE WITH IEC 60335-1
 THIS IS BASED ON THE PRODUCT MEETING A GWEPT 850°C TEST
 AND A RESIN GWIT >=775°C

THIS DRAWING IS A CONTROLLED DOCUMENT.		DWN: TOMMY_WU 09JUL2012	TE Connectivity
DIMENSIONS: mm		CHK: HAPYE_WU 09JUL2012	
TOLERANCES UNLESS OTHERWISE SPECIFIED:		APVD: YUHONG_MAO 09JUL2012	NAME: PLUG HOUSING, SINGLE ROW POWER TRIPLE LOCK
0 PLC	±	PRODUCT SPEC	108-106118
1 PLC	±0.35	APPLICATION SPEC	114-106118
2 PLC	±0.25	SIZE	A1
3 PLC	±	CAGE CODE	00779
4 PLC	±	DRAWING NO	1971773
ANGLES	±	WEIGHT	-
FINISH	-	Customer Drawing	SCALE 5:1 SHEET 1 OF 2 REV G

LOC	DIST	REVISIONS			
P	LTN	DESCRIPTION	DATE	OWN	APVD
-	-	SEE SHEET 1	-	-	-

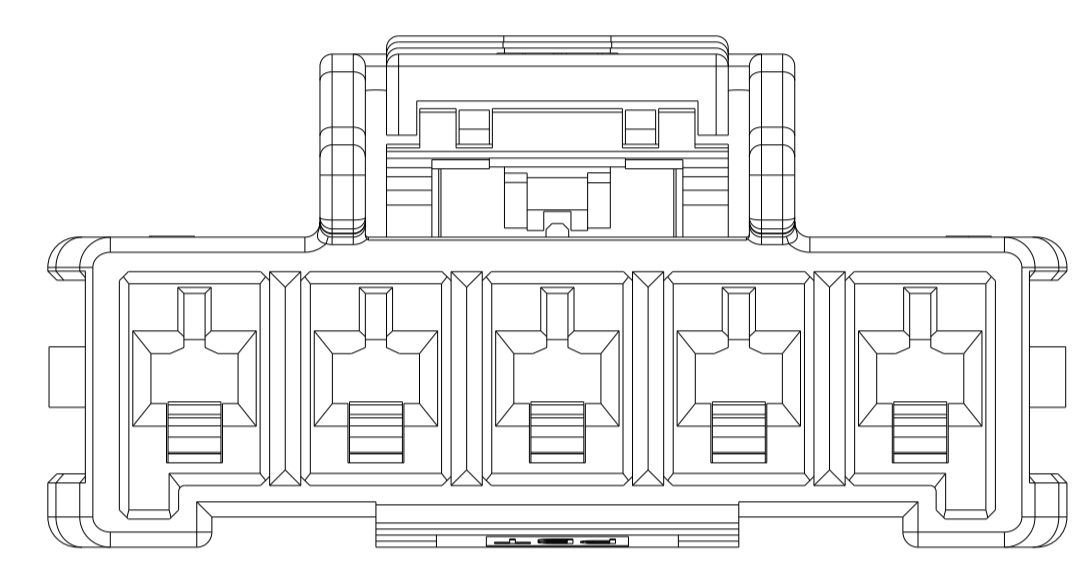
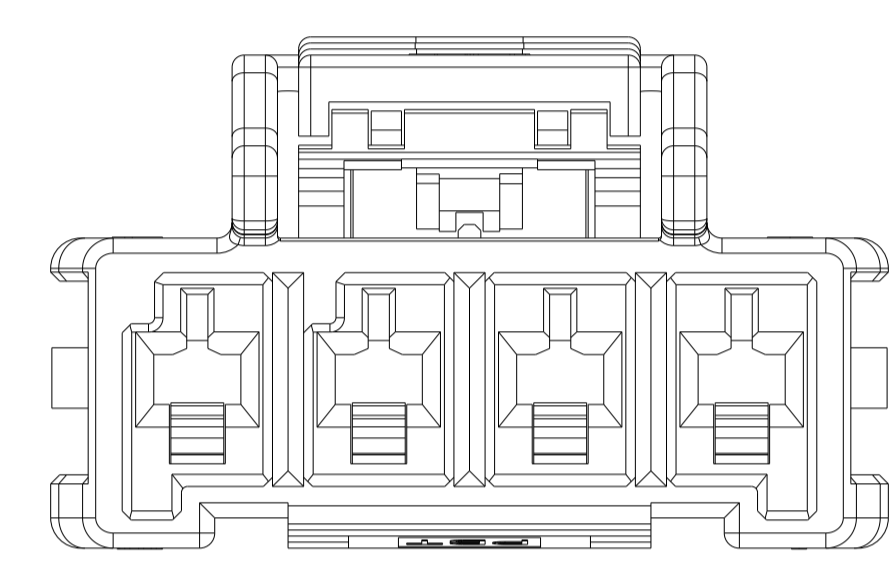
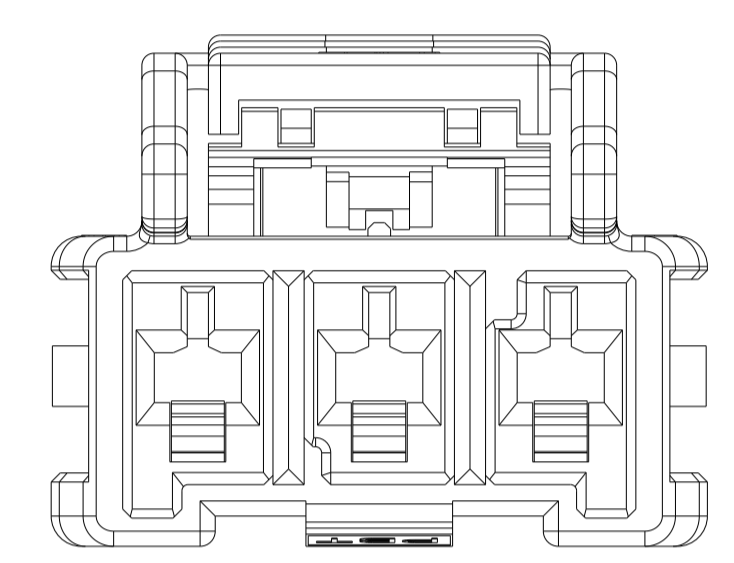
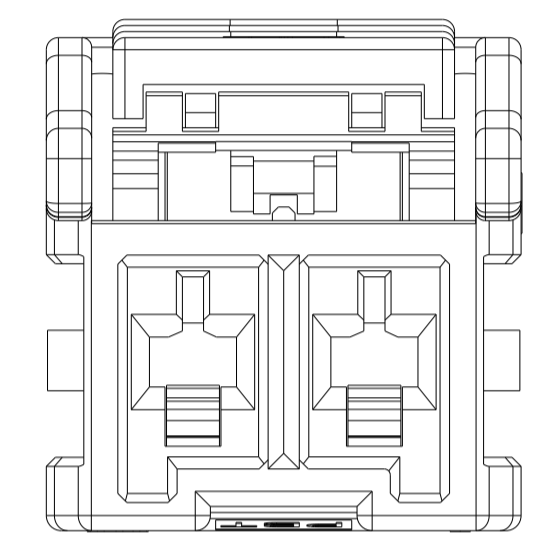
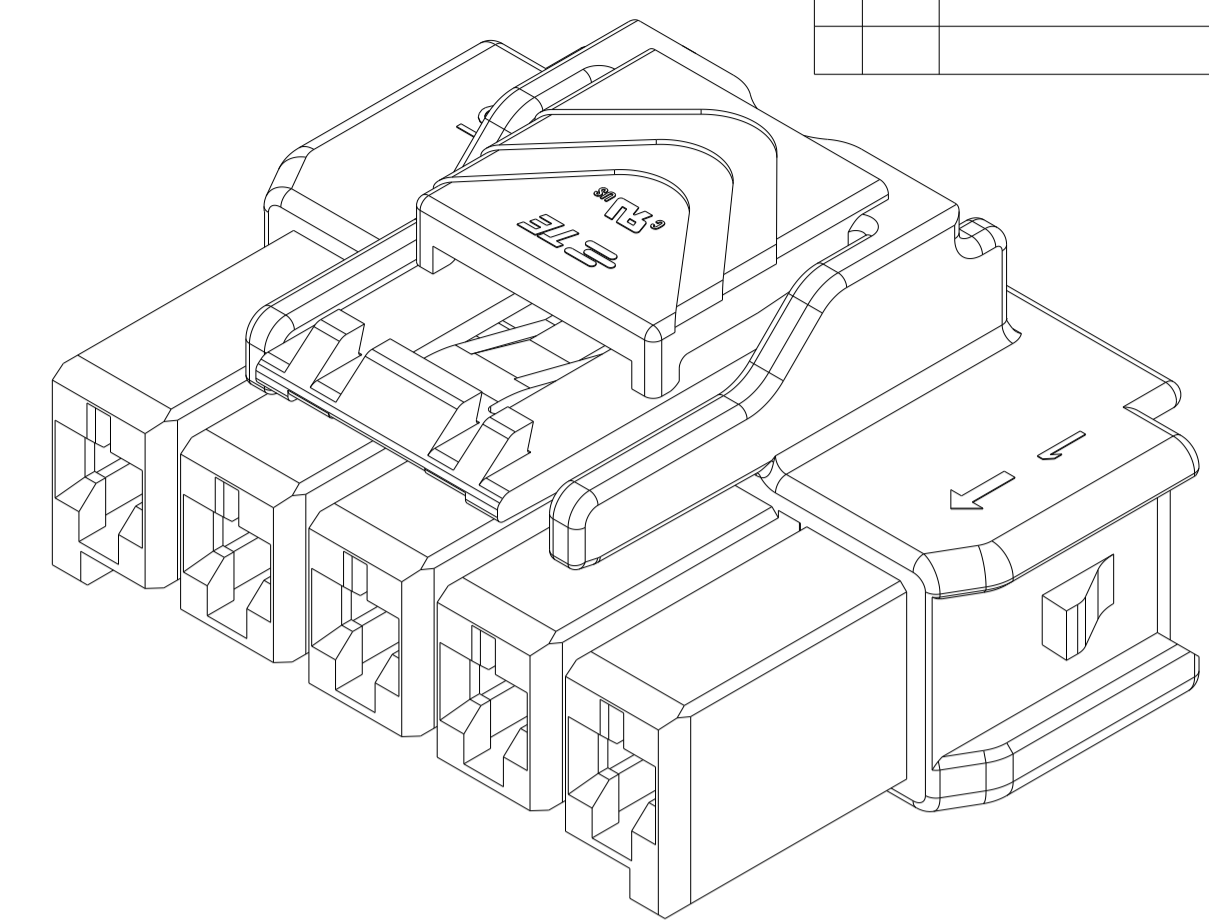
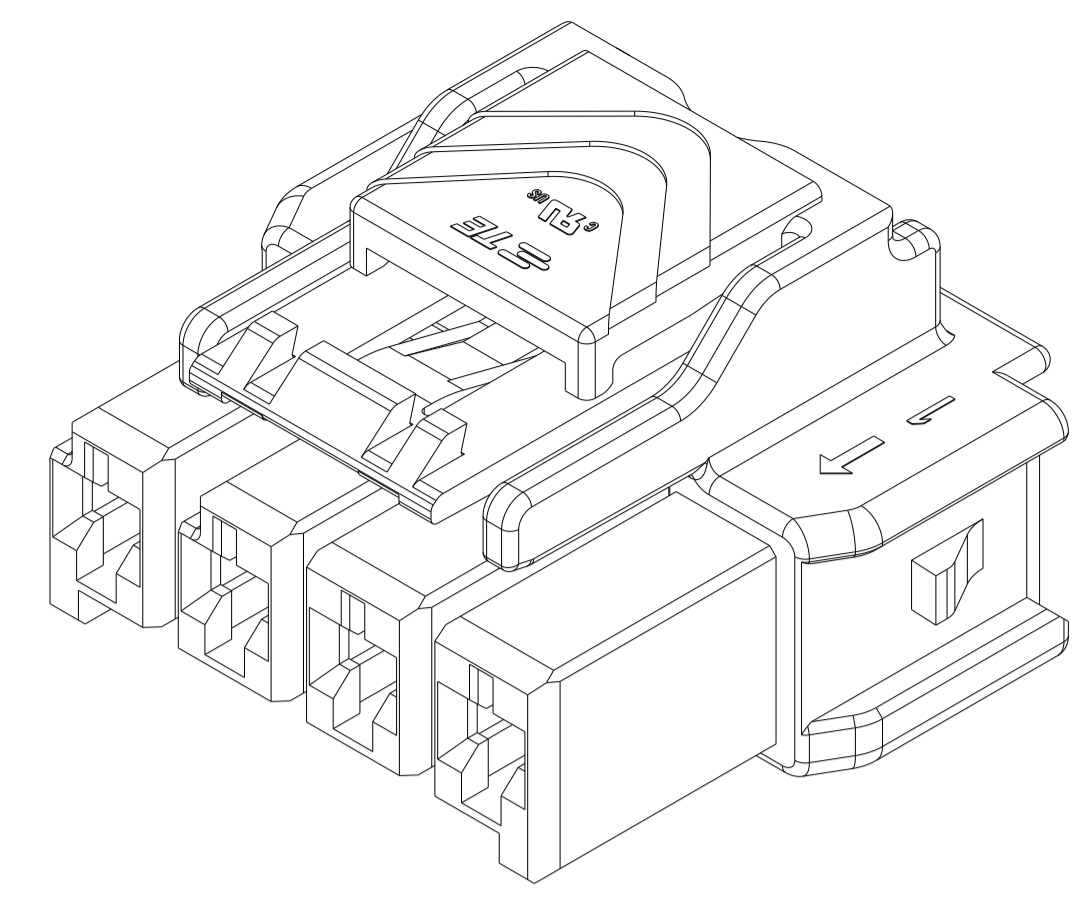
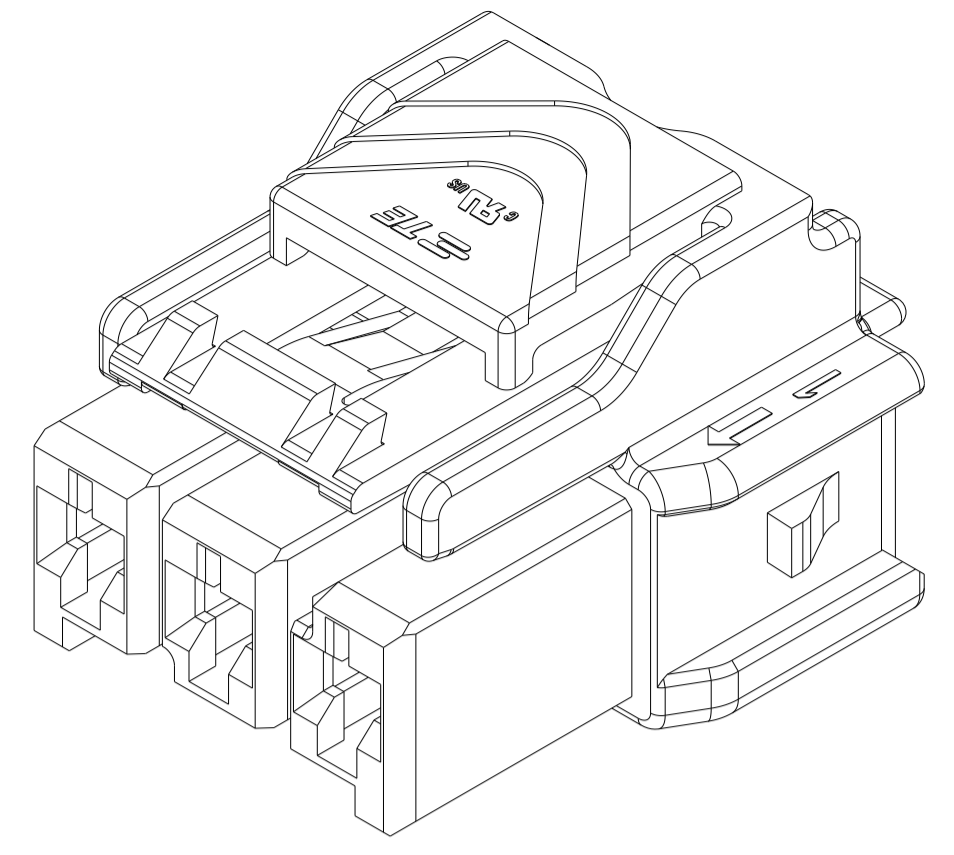
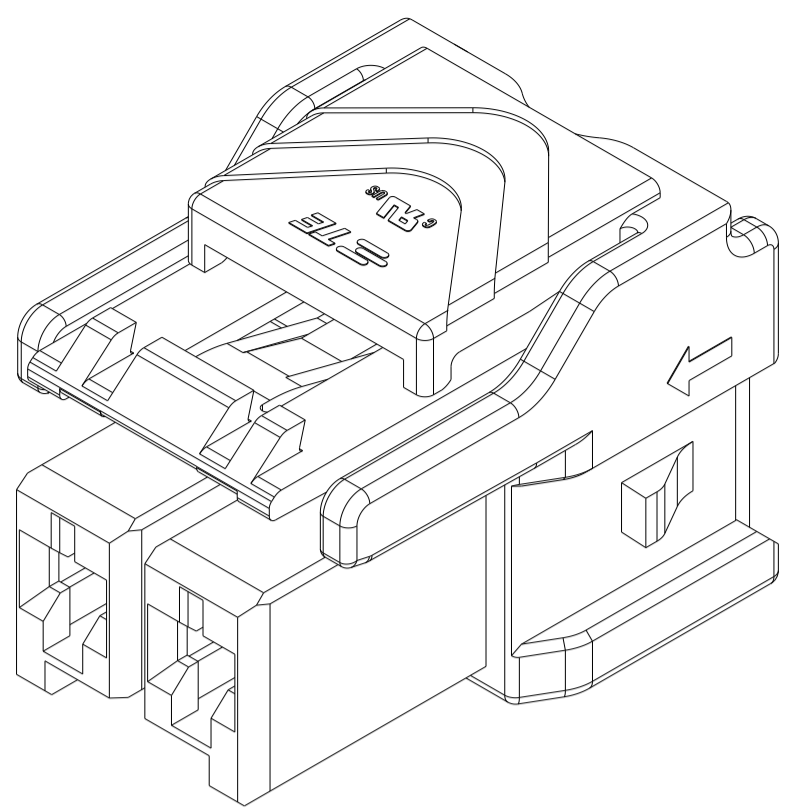

1*2 POSITIONS

1*3 POSITIONS

1*4 POSITIONS

1*5 POSITIONS

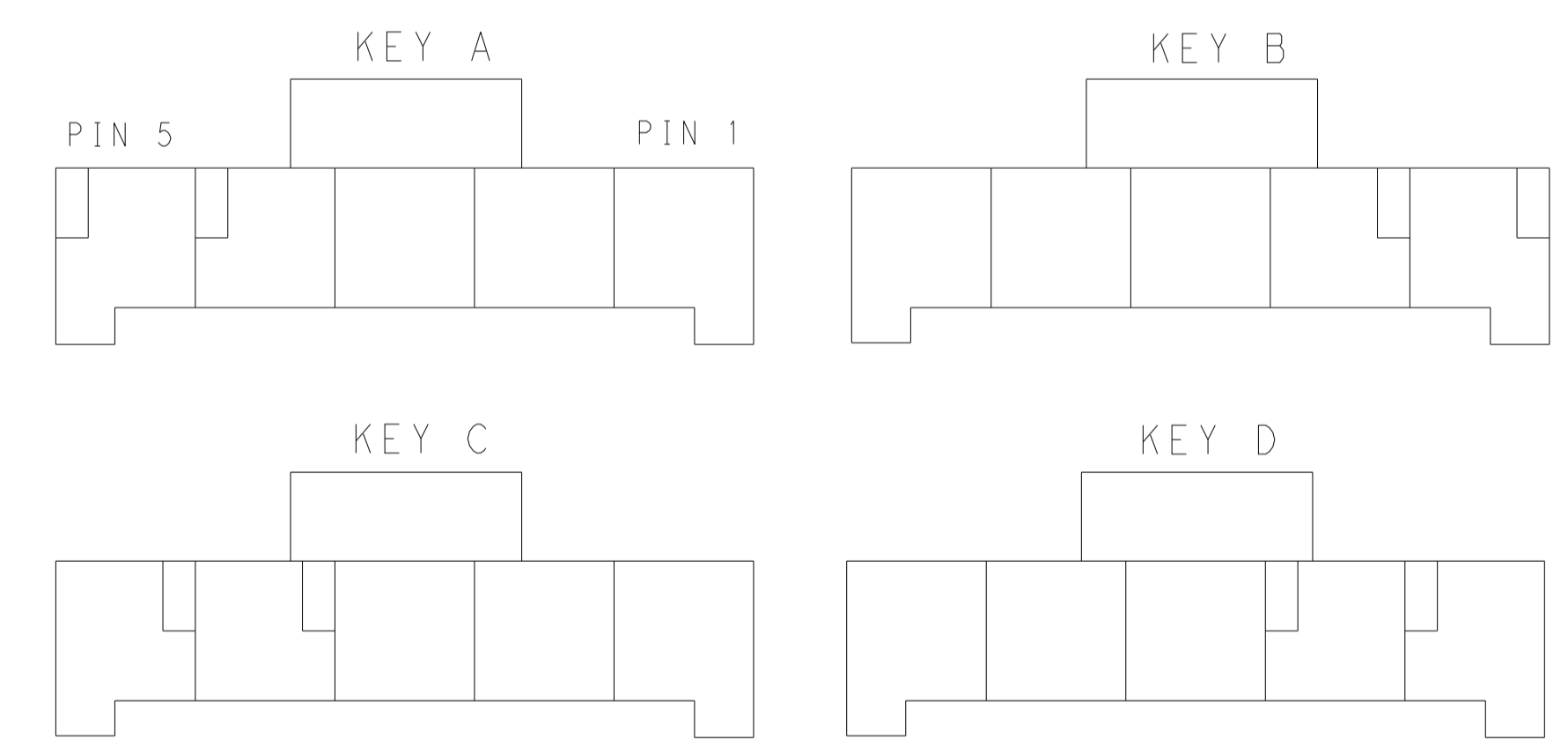
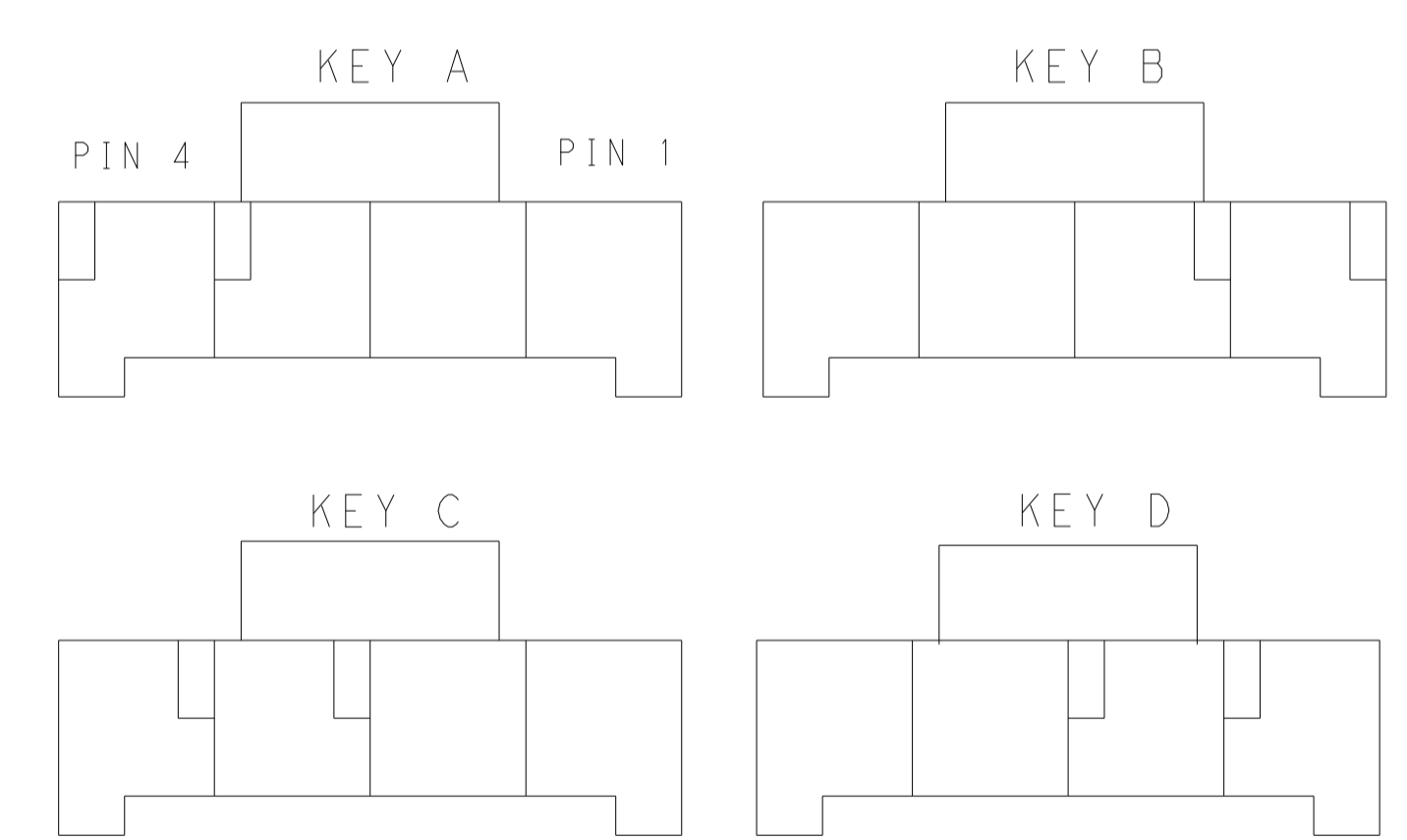
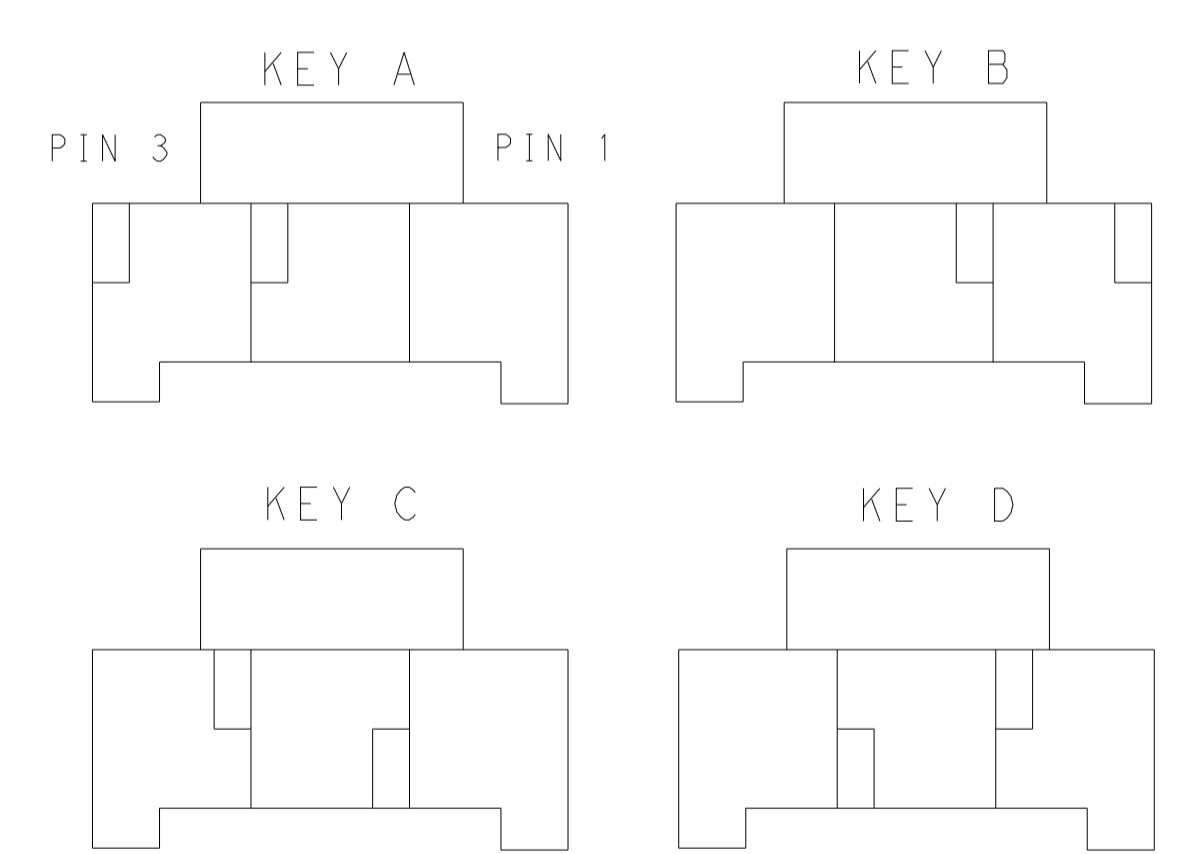
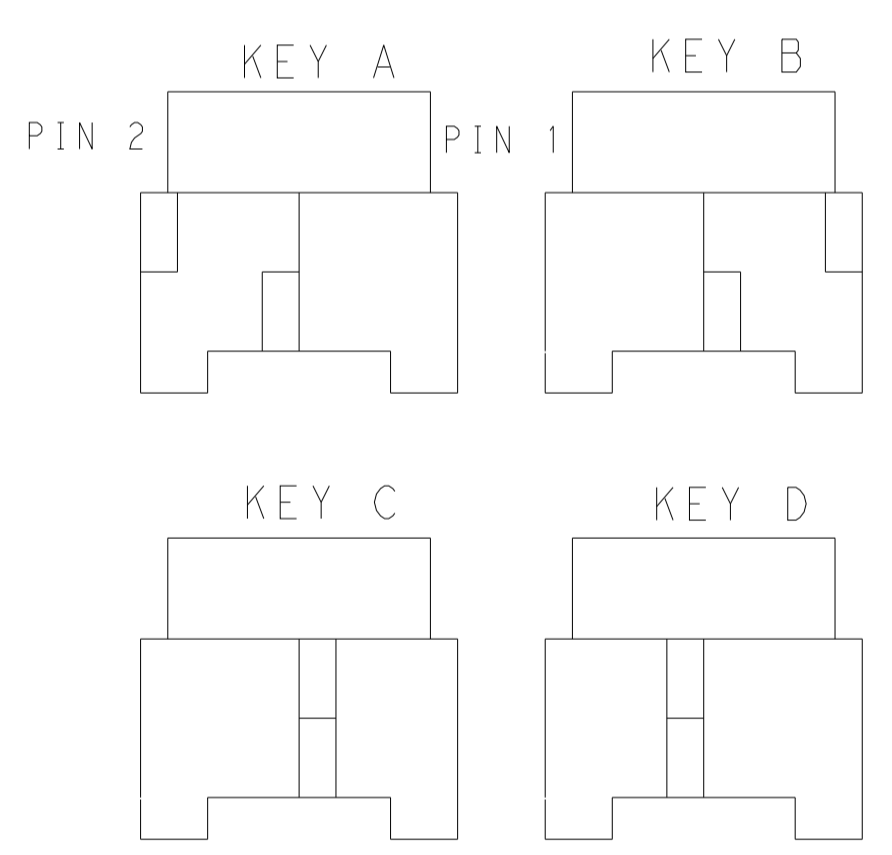

KEYING FOR 1*2 POS.

KEYING FOR 1*3 POS.

KEYING FOR 1*4 POS.

KEYING FOR 1*5 POS.

POS.	MATERIAL	KEY	P/N
1*3	LEVEL 1	KEY A	1-1971773-3
		KEY B	2-1971773-3
		KEY C	3-1971773-3
		KEY D	4-1971773-3
	LEVEL 2 △6	KEY A	5-1971773-3
		KEY B	6-1971773-3
		KEY C	7-1971773-3
		KEY D	8-1971773-3
1*2	LEVEL 1	KEY B	2-1971773-2
		KEY C	3-1971773-2
		KEY D	4-1971773-2
		KEY A	1-1971773-2
	LEVEL 2 △6	KEY A	9-1971773-2
		KEY B	6-1971773-2
		KEY C	7-1971773-2
		KEY D	8-1971773-2

POS.	MATERIAL	KEY	P/N
1*5	LEVEL 1	KEY A	1-1971773-7
		KEY B	2-1971773-7
		KEY C	3-1971773-7
		KEY D	4-1971773-7
	LEVEL 2 △6	KEY A	5-1971773-7
		KEY B	6-1971773-7
		KEY C	7-1971773-7
		KEY D	8-1971773-7
1*4	LEVEL 1	KEY B	2-1971773-4
		KEY C	3-1971773-4
		KEY D	4-1971773-4
		KEY A	1-1971773-4
	LEVEL 2 △6	KEY A	5-1971773-4
		KEY B	6-1971773-4
		KEY C	7-1971773-4
		KEY D	8-1971773-4

THIS DRAWING IS A CONTROLLED DOCUMENT.

DIMENSIONS:	TOLERANCES UNLESS OTHERWISE SPECIFIED:	OWN: TOMMY WU 09JUL2012	CHK: HAPYE WU 09JUL2012	APVD: YUHONG MAO 09JUL2012
mm	0 PLC ±- 1 PLC ±0.35 2 PLC ±0.25 3 PLC ±- 4 PLC ±- ANGLES ±- FINISH	NAME: YUHONG MAO	PRODUCT SPEC: 108-106118	APPLICATION SPEC: 114-106118
MATERIAL:		SIZE: A1	CAGE CODE: 00779	DRAWING NO: C=1971773
		WEIGHT:	Customer Drawing	SCALE: 5:1 SHEET 2 OF 2 REV G

STE TE Connectivity
PLUG HOUSING, SINGLE ROW
POWER TRIPLE LOCK