

THIS DRAWING CONTAINS INFORMATION PROPRIETARY TO RF INDUSTRIES.
 ANY UNAUTHORIZED USE OF THIS DRAWING IS EXPRESSLY PROHIBITED.
 WITHOUT WRITTEN PERMISSION FROM RF INDUSTRIES.
 ANY VIOLATION IS PUNISHABLE UNDER U.S. COPYRIGHT LAWS.

ALL DIMENSIONS ARE REFERENCE ONLY

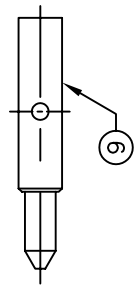

SOLDER RECOMMENDED

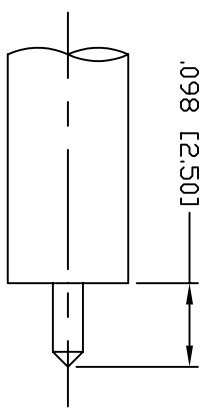
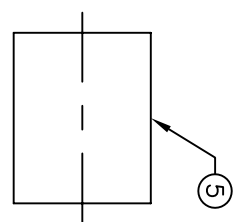
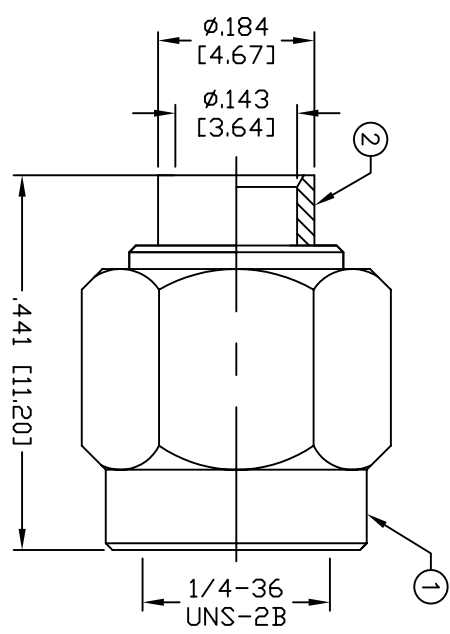

RECOMMENDED STRIPPING DIMENSIONS

SPECIFICATIONS:

IMPEDANCE: 50 Ohms
 FREQUENCY RANGE: 0-18 GHz
 INSERTION LOSS(DB): $0.03 \times \sqrt{f(\text{GHz})}$
 VSWR: 1.3 MAX.
 WORKING VOLTAGE: 500 V rms Max. @ Sea Level
 INSULATION RESISTANCE: 5000 Megohms
 TEMPERATURE RANGE: -65°C TO 165°C
 FOR .141 SEMI RIGID, RG-402/U & BELDEN 1673A CABLE

1	SHELL	1	BRASS	GOLD, 3μ"			
2	BODY	1	BRASS	GOLD, 3μ"	008974		
3	RETAINING RING	1	Be.Cu.	---			
4	GASKET	1	SILICONE	RED			
5	INSULATOR	1	PTFE	---			
6	PIN	1	BRASS	GOLD, 50μ"			
7							
8							
9							
10							
11							
12							
13							
14							
#	DESCRIPTION	QTY	MATERIAL	FINISH	APPROVALS	DATE	

UNLESS OTHERWISE SPECIFIED:
 1. REMOVE ALL BURRS
 2. BREAK ALL CORNERS & EDGES .005 R. MAX.
 3. CHAMFER 1ST & LAST THREADS 45°
 4. SURFACE ROUGHNESS 63 FINISH MIL-STD-10
 5. DIAMETERS ON COMMON CENTERS TO BE CONCENTRIC WITHIN .002 T.I.R.
 6. ALL DIMENSIONS ARE AFTER PLATING.

DIMENSIONS ARE IN INCHES AND [MILLIMETERS]
 UNLESS OTHERWISE NOTED TOLERANCES ARE:
 DECIMALS DIAMETER .XXX±.001 [.03]
 .XXX±.003 [.08]
 .XX±.005 [.13]

PART NO.		RSA-3500-1-141	
REV	DESCRIPTION	DWN	DATE
-	ENGINEERING RELEASE	CZS	6/5/00
			APPROVED
			JDMc



7610 MIRAMAR RD
 SAN DIEGO, CA 92126
 (858) 549-6340
 (858) 549-6345 FAX

SMA PLUG

SEMI RIGID, SOLDER

SIZE	CABLE GROUP	DWG NO.	REV
A	SR2	RSA-3500-1-141	-
SCALE:	NTS	CAD FILE	OUTLINE
SHEET	1	OF	1