

This document is the property of Amphenol Corporation and is delivered on the express condition that is not to be disclosed, reproduced or used, in whole or in part, for manufacture or sale by anyone other than Amphenol Corporation without its prior consent, and that no right is granted to disclose or to use any information in this document.
The marking on this product doesn't contain environmental hazardous materials per directive 2011/65/EU for RoHS compliant.



ORIGINAL



REVISIONS				
SYM	ECN No.	DESCRIPTION	DATE	APPROVED
A	NE-20033	APPROVED REVISION	03/12/2020	Roger Tsai

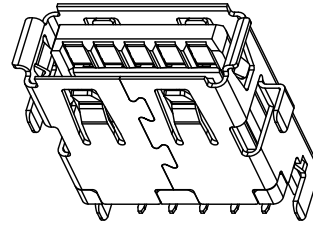

NOTES:

- MATERIAL:
HOUSING: PA4T HF, UL94V-0, COLOR: BLUE.
TERMINAL(5P): COPPER ALLOY.
TERMINAL(4P): COPPER ALLOY.
SHELL: SUS201.
- FINISH:
TERMINAL:
CONTACT AREA: SELECTED GOLD PLATING THICKNESS MIN.;
SOLDERING AREA: MATTE TIN PLATING 100 μ" THICKNESS MIN.;
UNDER PLATING: NICKEL PLATING 50μ" THICKNESS MIN. OVERALL.
SHELL:
NICKEL PLATING 50 μ" THICKNESS MIN. OVERALL.
- PRODUCT SPECIFICATION REFER TO : PS-7425.
- THIS PRODUCT DOESN'T CONTAIN ENVIRONMENTAL HAZARDOUS PER DIRECTIVE 2011/65/EU FOR RoHS COMPLIANT.
OR PER IEC 61249-2-21 FOR HALOGEN-FREE COMPLIANT.

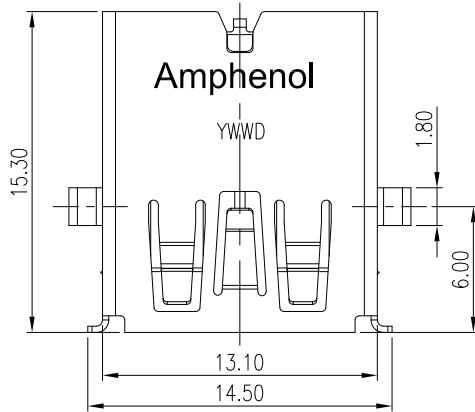

PART NO. GSB311R X 9 X C1HR

- CONTACT FINISH: DIM A:
- 1: GOLD FLASH 1: 1.70mm
 - 2: 15 μ" GOLD 2: 3.0mm
 - 3: 30 μ" GOLD

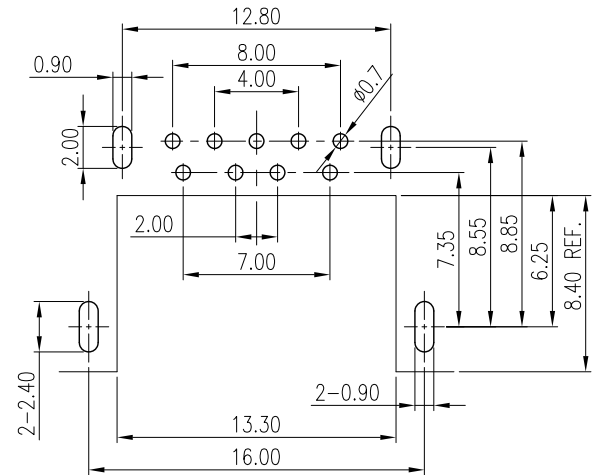
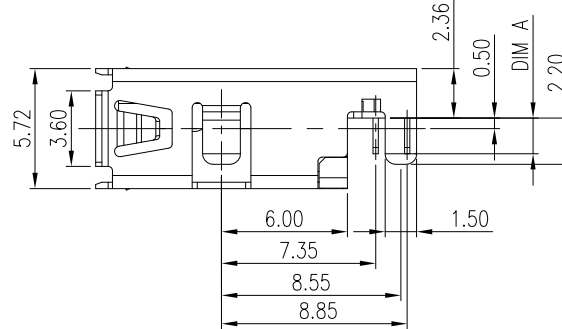
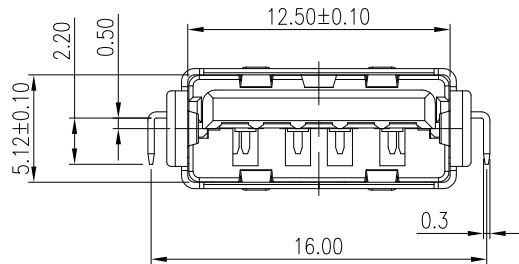

RECOMMENDED P.C.B LAYOUT
TOLERANCE: ±0.05

TOLERANCE		APPROVALS		DATE	TITLE		Amphenol®						
X.		DRAWN	Debby Hung	03/12/2020	GSB3 SERIES, USB 3.0		Amphenol Corporation						
X.X	±0.30	CHECKED	Sandy Wu	03/12/2020	A TYPE, RECEPTACLE, SINGLE PORT, R/A, SINK, DIP TYPE		Amphenol Taiwan Corporation						
X.XX	±0.20	APPROVED	Roger Tsai	03/12/2020		UNIT	mm	SIZE	A3	PART No.	GSB311RX9XC1HR		
X.XXX	±0.10	DWG TYPE	CUST DWG	PROJECT CODE		OTHER	SCALE	NA	SHEET	1 OF 2	DWG No.	GSB311RX9XC1HR	REV.
ANGULAR	±1°												
UNLESS OTHERWISE SPECIFIED													

This document is the property of Amphenol Corporation and is delivered on the express condition that it is not to be disclosed, reproduced or used, in whole or in part, for manufacture or sale by anyone other than Amphenol Corporation without its prior consent, and that no right is granted to disclose or to use any information in this document.
The marking on this product doesn't contain environmental hazardous materials per directive 2011/65/EU for RoHS compliant.



ORIGINAL



REVISIONS				
SYM	ECN No.	DESCRIPTION	DATE	APPROVED
A	NE-20033	APPROVED REVISION	03/12/2020	Roger Tsai

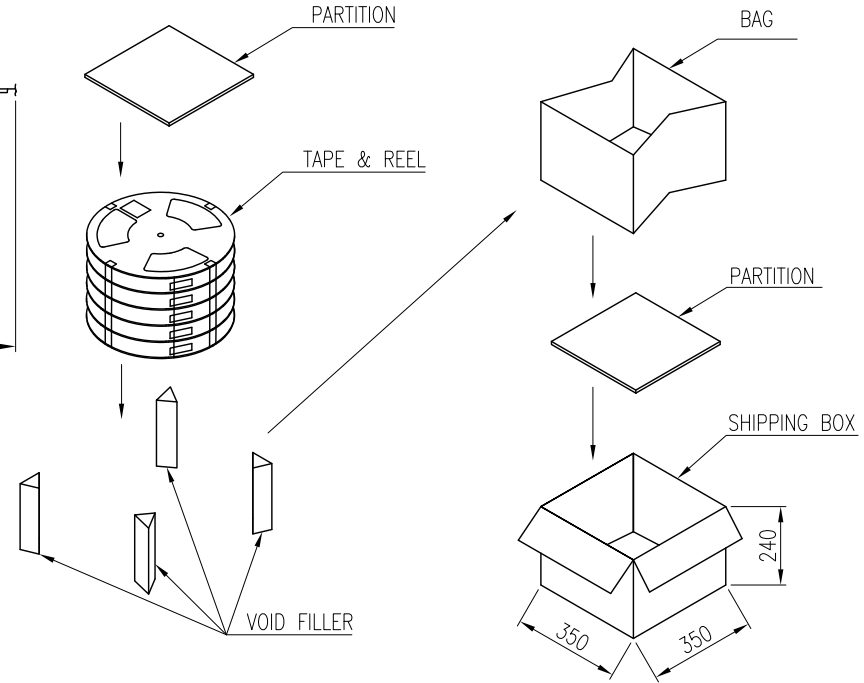
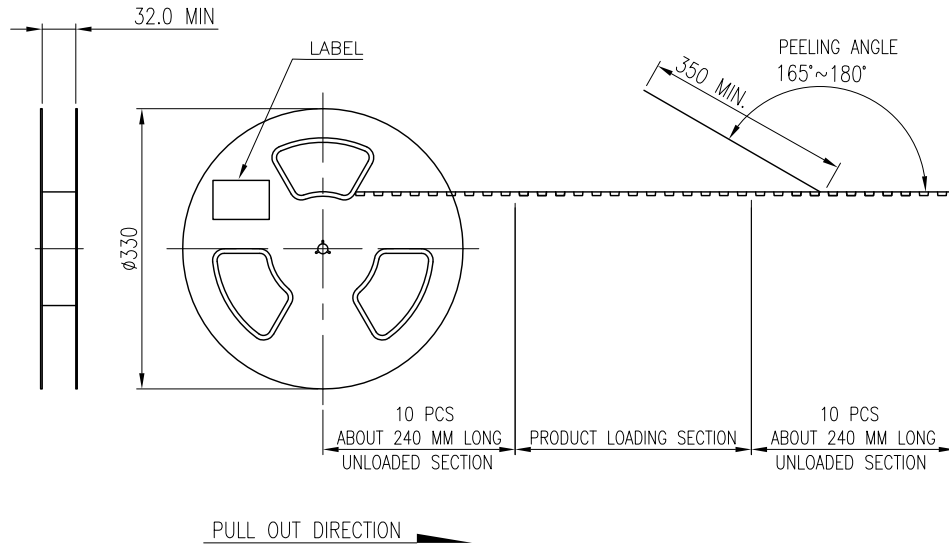

NOTES:

- MATERIAL:
CARRIER TAPE: PS.
COVER TAPE: PET.
REEL: PS.
SHIPPING BOX: CORRUGATED FIBERBOARD.
- DIMENSION:
REEL: $\phi = 330$.
SHIPPING BOX: L=350, W=350, H=240.
- PEELING STRENGTH: 0.1~1.3N(10~130 GRAMS)
- PEELING SPEED: 300mm/min.

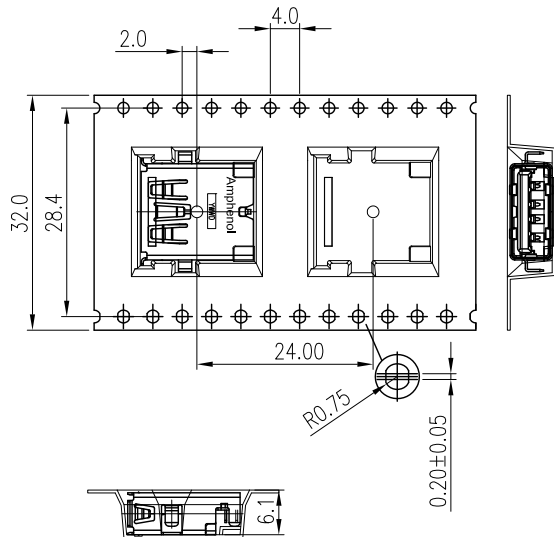

PACKAGING BY T&R	6.3	4.8	400	6	2400	GSB311RX9XC1HR
	G/W KG	N/W KG	PCS/ REEL	REELS/ BOX	QUANTITY (PCS)	PART NUMBER

TOLERANCE	APPROVALS	DATE	TITLE		PART No.	
X. ±0.30	DRAWN Debby Hung	03/12/2020	GSB3 SERIES, USB 3.0 A TYPE, RECEPTACLE, SINGLE PORT, R/A, SINK, DIP TYPE		Amphenol [®] Amphenol Corporation Amphenol Taiwan Corporation	
X.X ±0.20	CHECKED Sandy Wu	03/12/2020				
X.XX ±0.10	APPROVED Roger Tsai	03/12/2020		UNIT mm	SIZE A3	PART No. GSB311RX9XC1HR
ANGULAR ±1°	DWG TYPE CUST DWG	PROJECT CODE OTHER		SCALE NA	SHEET 2 OF 2	DWG No. GSB311RX9XC1HR
UNLESS OTHERWISE SPECIFIED						