

FEATURES:

- Guaranteed Low Skew < 25ps (max)
- Very low duty cycle distortion
- High speed propagation delay < 2.5ns. (max)
- Up to 250MHz operation
- Very low CMOS power levels
- 1.5V V_{DDQ} for HSTL interface
- Hot insertable and over-voltage tolerant inputs
- 3-level inputs for selectable interface
- Selectable HSTL, eHSTL, 1.8V / 2.5V LVTTTL, or LVEPECL input interface
- Selectable differential or single-ended inputs and five single-ended outputs
- 2.5V V_{DD}
- Available in TSSOP package
- *For new designs use functional replacement 8L30110*

DESCRIPTION:

The 5T90533 2.5V single data rate (SDR) clock buffer is a user-selectable single-ended or differential input to five single-ended outputs buffer built on advanced metal CMOS technology. The SDR clock buffer fanout from a single or differential input to five single-ended outputs reduces the loading on the preceding driver and provides an efficient clock distribution network. The 5T90533 can act as a translator from a differential HSTL, eHSTL, 1.8V/2.5V LVTTTL, LVEPECL, or single-ended 1.8V/2.5V LVTTTL input to HSTL, eHSTL, 1.8V/2.5V LVTTTL outputs. Selectable interface is controlled by 3-level input signals that may be hard-wired to appropriate high-mid-low levels. Multiple power and grounds reduce noise.

APPLICATIONS:

- Clock and signal distribution

FUNCTIONAL BLOCK DIAGRAM

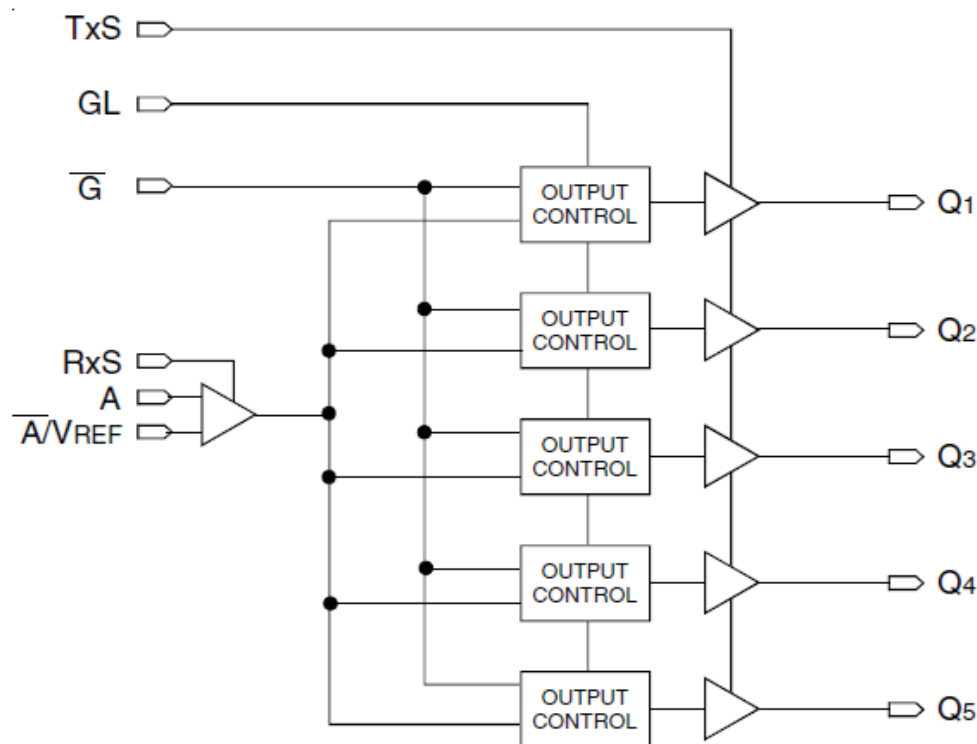

PIN CONFIGURATION

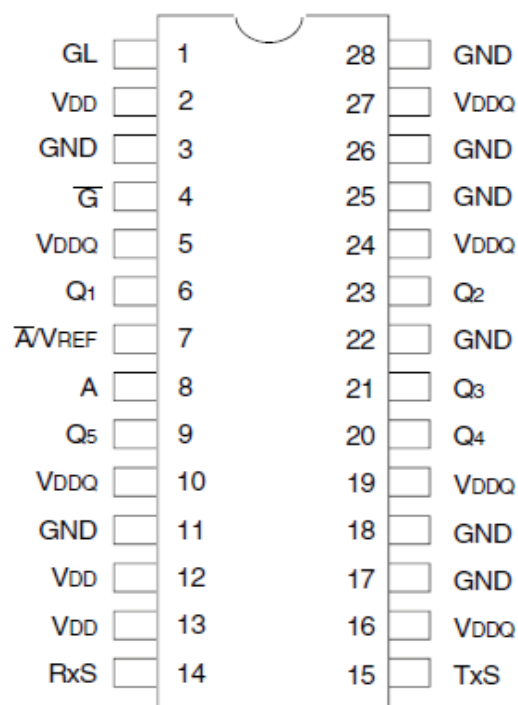

TSSOP
TOP VIEW

ABSOLUTE MAXIMUM RATINGS⁽¹⁾

Symbol	Description	Max	Unit
V _{DD}	Power Supply Voltage ⁽²⁾	-0.5 to +3.6	V
V _{DDQ}	Output Power Supply ⁽²⁾	-0.5 to +3.6	V
V _I	Input Voltage	-0.5 to +3.6	V
V _O	Output Voltage ⁽³⁾	-0.5 to V _{DDQ} +0.5	V
V _{REF}	Reference Voltage ⁽³⁾	-0.5 to +3.6	V
T _{STG}	Storage Temperature	-65 to +165	°C
T _J	Junction Temperature	150	°C

NOTES:

- Stresses greater than those listed under ABSOLUTE MAXIMUM RATINGS may cause permanent damage to the device. This is a stress rating only and functional operation of the device at these or any other conditions above those indicated in the operational sections of this specification is not implied. Exposure to absolute maximum rating conditions for extended periods may affect reliability.
- V_{DDQ} and V_{DD} internally operate independently. No power sequencing requirements need to be met.
- Not to exceed 3.6V.

CAPACITANCE^(1,2) (T_A = +25°C, F = 1.0MHz)

Symbol	Parameter	Min	Typ.	Max.	Unit
C _{IN}	Input Capacitance	—	3.5	—	pF

NOTES:

- This parameter is measured at characterization but not tested.
- Capacitance applies to all inputs except RxS and TxS.

RECOMMENDED OPERATING RANGE

Symbol	Description	Min.	Typ.	Max.	Unit
T _A	Ambient Operating Temperature	-40	+25	+85	°C
V _{DD} ⁽¹⁾	Internal Power Supply Voltage	2.4	2.5	2.6	V
V _{DDQ} ⁽¹⁾	HSTL Output Power Supply Voltage	1.4	1.5	1.6	V
	Extended HSTL and 1.8V LVTTTL Output Power Supply Voltage	1.65	1.8	1.95	V
	2.5V LVTTTL Output Power Supply Voltage		V _{DD}		V
V _T	Termination Voltage		V _{DDQ} / 2		V

NOTE:

- All power supplies should operate in tandem. If V_{DD} or V_{DDQ} is at maximum, then V_{DDQ} or V_{DD} (respectively) should be at maximum, and vice-versa.

PIN DESCRIPTION

Symbol	I/O	Type	Description
A	I	Adjustable ⁽¹⁾	Clock input. A is the "true" side of the differential clock input. If operating in single-ended mode, A is the clock input.
\bar{A}/V_{REF}	I	Adjustable ⁽¹⁾	Complementary clock input. \bar{A}/V_{REF} is the "complementary" side of A if the input is in differential mode. If operating in single-ended mode, \bar{A}/V_{REF} is connected to GND. For single-ended operation in differential mode, \bar{A}/V_{REF} should be set to the desired toggle voltage for A: <div style="margin-left: 40px;"> 2.5V LVTTTL $V_{REF} = 1250\text{mV}$ 1.8V LVTTTL, eHSTL $V_{REF} = 900\text{mV}$ HSTL $V_{REF} = 750\text{mV}$ LVEPECL $V_{REF} = 1082\text{mV}$ </div>
\bar{G}	I	LVTTTL ⁽⁵⁾	Gate control for Qn outputs. When \bar{G} is LOW, these outputs are enabled. When \bar{G} is HIGH, these outputs are asynchronously disabled to the level designated by GL ⁽⁴⁾ .
GL	I	LVTTTL ⁽⁵⁾	Specifies output disable level. If HIGH, the outputs disable HIGH. If LOW, the outputs disable LOW.
Qn	O	Adjustable ⁽²⁾	Clock outputs
RxS	I	3 Level ⁽³⁾	Selects single-ended 2.5V LVTTTL (HIGH), 1.8V LVTTTL (MID) clock input or differential (LOW) clock input
TxS	I	3 Level ⁽³⁾	Sets the drive strength of the output drivers to be 2.5V LVTTTL (HIGH), 1.8V LVTTTL (MID) or HSTL (LOW) compatible. Used in conjunction with V_{DD0} to set the interface levels.
V_{DD}		PWR	Power supply for the device core and inputs
V_{DD0}		PWR	Power supply for the device outputs. When utilizing 2.5V LVTTTL outputs, V_{DD0} should be connected to V_{DD} .
GND		PWR	Power supply return for all power

NOTES:

- Inputs are capable of translating the following interface standards. User can select between:
 - Single-ended 2.5V LVTTTL levels
 - Single-ended 1.8V LVTTTL levels
 - or
 - Differential 2.5V/1.8V LVTTTL levels
 - Differential HSTL and eHSTL levels
 - Differential LVEPECL levels
- Outputs are user selectable to drive 2.5V, 1.8V LVTTTL, eHSTL, or HSTL interface levels when used with the appropriate V_{DD0} voltage.
- 3 level inputs are static inputs and must be tied to V_{DD} or GND or left floating. These inputs are not hot-insertable or over-voltage tolerant.
- Because the gate controls are asynchronous, runt pulses are possible. It is the user's responsibility to either time the gate control signals to minimize the possibility of runt pulses or be able to tolerate them in down stream circuitry.
- Pins listed as LVTTTL inputs will accept 2.5V signals when RxS = HIGH or 1.8V signals when RxS = LOW or MID.

INPUT/OUTPUT SELECTION⁽¹⁾

Input	Output	Input	Output		
2.5V LVTTTL SE	2.5V LVTTTL	2.5V LVTTTL SE	eHSTL		
1.8V LVTTTL SE		1.8V LVTTTL SE			
2.5V LVTTTL DSE		2.5V LVTTTL DSE			
1.8V LVTTTL DSE		1.8V LVTTTL DSE			
LVEPECL DSE		LVEPECL DSE			
eHSTL DSE		eHSTL DSE			
HSTL DSE		HSTL DSE			
2.5V LVTTTL DIF		2.5V LVTTTL DIF			
1.8V LVTTTL DIF		1.8V LVTTTL DIF			
LVEPECL DIF		LVEPECL DIF			
eHSTL DIF		eHSTL DIF			
HSTL DIF		HSTL DIF			
2.5V LVTTTL SE		1.8V LVTTTL		2.5V LVTTTL SE	HSTL
1.8V LVTTTL SE				1.8V LVTTTL SE	
2.5V LVTTTL DSE	2.5V LVTTTL DSE				
1.8V LVTTTL DSE	1.8V LVTTTL DSE				
LVEPECL DSE	LVEPECL DSE				
eHSTL DSE	eHSTL DSE				
HSTL DSE	HSTL DSE				
2.5V LVTTTL DIF	2.5V LVTTTL DIF				
1.8V LVTTTL DIF	1.8V LVTTTL DIF				
LVEPECL DIF	LVEPECL DIF				
eHSTL DIF	eHSTL DIF				
HSTL DIF	HSTL DIF				

NOTE:
 1. The INPUT/OUTPUT SELECTION Table describes the total possible combinations of input and output interfaces. Single-Ended (SE) inputs in a single-ended mode require the $\bar{A}V_{REF}$ pin to be connected to GND. Differential Single-Ended (DSE) is for single-ended operation in differential mode, requiring a V_{REF} . Differential (DIF) inputs are used only in differential mode.

DC ELECTRICAL CHARACTERISTICS OVER OPERATING RANGE

Symbol	Parameter	Test Conditions	Min.	Max.	Unit
V_{IH}	Input HIGH Voltage Level ⁽¹⁾	3-Level Inputs Only	$V_{DD} - 0.4$	—	V
V_{IMM}	Input MID Voltage Level ⁽¹⁾	3-Level Inputs Only	$V_{DD}/2 - 0.2$	$V_{DD}/2 + 0.2$	V
V_{IL}	Input LOW Voltage Level ⁽¹⁾	3-Level Inputs Only	—	0.4	V
I_3	3-Level Input DC Current (RxS, TxS)	$V_{IN} = V_{DD}$ HIGH Level	—	200	μA
		$V_{IN} = V_{DD}/2$ MID Level	-50	+50	
		$V_{IN} = GND$ LOW Level	-200	—	

NOTE:
 1. These inputs are normally wired to V_{DD} , GND, or left floating. Internal termination resistors bias unconnected unputs to $V_{DD}/2$.

DC ELECTRICAL CHARACTERISTICS OVER OPERATING RANGE FOR HSTL⁽¹⁾

Symbol	Parameter	Test Conditions	Min.	Typ. ⁽⁷⁾	Max	Unit
Input Characteristics						
I _{IH}	Input HIGH Current ⁽⁹⁾	V _{DD} = 2.6V V _I = V _{DDQ} /GND	—	—	+5	μA
I _{IL}	Input LOW Current ⁽⁹⁾	V _{DD} = 2.6V V _I = GND/V _{DDQ}	—	—	+5	
V _{IK}	Clamp Diode Voltage	V _{DD} = 2.4V, I _{IN} = -18mA	—	-0.7	-1.2	V
V _{IN}	DC Input Voltage		-0.3		+3.6	V
V _{DIF}	DC Differential Voltage ^(2,8)		0.2		—	V
V _{CM}	DC Common Mode Input Voltage ^(3,8)		680	750	900	mV
V _{IH}	DC Input HIGH ^(4,5,8)		V _{REF} + 100		—	mV
V _{IL}	DC Input LOW ^(4,5,8)		—		V _{REF} - 100	mV
V _{REF}	Single-Ended Reference Voltage ^(4,8)		—	750	—	mV
Output Characteristics						
V _{OH}	Output HIGH Voltage	I _{OH} = -8mA	V _{DDQ} - 0.4		—	V
		I _{OH} = -100μA	V _{DDQ} - 0.1		—	V
V _{OL}	Output LOW Voltage	I _{OL} = 8mA	—		0.4	V
		I _{OL} = 100μA	—		0.1	V

NOTES:

- See RECOMMENDED OPERATING RANGE table.
- V_{DIF} specifies the minimum input differential voltage (V_{TR} - V_{CP}) required for switching where V_{TR} is the "true" input level and V_{CP} is the "complement" input level. Differential mode only. The DC differential voltage must be maintained to guarantee retaining the existing HIGH or LOW input. The AC differential voltage must be achieved to guarantee switching to a new state.
- V_{CM} specifies the maximum allowable range of (V_{TR} + V_{CP}) / 2. Differential mode only.
- For single-ended operation, in differential mode, $\bar{A}V_{REF}$ is tied to the DC voltage V_{REF}.
- Voltage required to maintain a logic HIGH, single-ended operation in differential mode.
- Voltage required to maintain a logic LOW, single-ended operation in differential mode.
- Typical values are at V_{DD} = 2.5V, V_{DDQ} = 1.5V, +25°C ambient.
- The reference clock input is capable of HSTL, eHSTL, LVEPECL, 1.8V or 2.5V LVTTTL operation independent of the device output. The correct input interface table should be referenced.
- For differential mode (R_{xS} = LOW), A and $\bar{A}V_{REF}$ must be at the opposite rail.

POWER SUPPLY CHARACTERISTICS FOR HSTL OUTPUTS⁽¹⁾

Symbol	Parameter	Test Conditions ⁽²⁾	Typ.	Max	Unit
I _{DDQ}	Quiescent V _{DD} Power Supply Current	V _{DDQ} = Max., Reference Clock = LOW ⁽³⁾ Outputs enabled. All outputs unloaded	20	30	mA
I _{DDQQ}	Quiescent V _{DDQ} Power Supply Current	V _{DDQ} = Max., Reference Clock = LOW ⁽³⁾ Outputs enabled. All outputs unloaded	0.1	0.3	mA
I _{DD}	Dynamic V _{DD} Power Supply Current per Output	V _{DD} = Max., V _{DDQ} = Max., C _L = 0pF	10	20	μA/MHz
I _{DDQ}	Dynamic V _{DDQ} Power Supply Current per Output	V _{DD} = Max., V _{DDQ} = Max., C _L = 0pF	15	30	μA/MHz
I _{TOT}	Total Power V _{DD} Supply Current	V _{DDQ} = 1.5V, F _{REFERENCE CLOCK} = 100MHz, C _L = 15pF	20	30	mA
		V _{DDQ} = 1.5V, F _{REFERENCE CLOCK} = 250MHz, C _L = 15pF	25	40	
I _{TOTQ}	Total Power V _{DDQ} Supply Current	V _{DDQ} = 1.5V, F _{REFERENCE CLOCK} = 100MHz, C _L = 15pF	15	30	mA
		V _{DDQ} = 1.5V, F _{REFERENCE CLOCK} = 250MHz, C _L = 15pF	30	60	

NOTES:

- These power consumption characteristics are for all the valid input interfaces and cover the worst case input and output interface combinations.
- The termination resistors are excluded from these measurements.
- If the differential input interface is used, the true input is held LOW and the complementary input is held HIGH.

DIFFERENTIAL INPUT AC TEST CONDITIONS FOR HSTL

Symbol	Parameter	Value	Units
V_{DIF}	Input Signal Swing ⁽¹⁾	1	V
V_X	Differential Input Signal Crossing Point ⁽²⁾	750	mV
V_{THI}	Input Timing Measurement Reference Level ⁽³⁾	Crossing Point	V
t_R, t_F	Input Signal Edge Rate ⁽⁴⁾	1	V/ns

NOTES:

- The 1V peak-to-peak input pulse level is specified to allow consistent, repeatable results in an automatic test equipment (ATE) environment. Compliant devices must meet the V_{DIF} (AC) specification under actual use conditions.
- A 750mV crossing point level is specified to allow consistent, repeatable results in an automatic test equipment (ATE) environment. Compliant devices must meet the V_X specification under actual use conditions.
- In all cases, input waveform timing is marked at the differential cross-point of the input signals.
- The input signal edge rate of 1V/ns or greater is to be maintained in the 20% to 80% range of the input waveform.

DC ELECTRICAL CHARACTERISTICS OVER OPERATING RANGE FOR eH-

Symbol	Parameter	Test Conditions	Min.	Typ. ⁽⁷⁾	Max	Unit
Input Characteristics						
I_{IH}	Input HIGH Current ⁽⁹⁾	$V_{DD} = 2.6V$ $V_I = V_{DDO}/GND$	—	—	+5	mA
I_{IL}	Input LOW Current ⁽⁹⁾	$V_{DD} = 2.6V$ $V_I = GND/V_{DDO}$	—	—	+5	mA
V_{IK}	Clamp Diode Voltage	$V_{DD} = 2.4V, I_{IN} = -18mA$	—	-0.7	-1.2	V
V_{IN}	DC Input Voltage		-0.3		+3.6	V
V_{DIF}	DC Differential Voltage ^(2,8)		0.2		—	V
V_{CM}	DC Common Mode Input Voltage ^(3,8)		800	900	1000	mV
V_{IH}	DC Input HIGH ^(4,5,8)		$V_{REF} + 100$		—	mV
V_{IL}	DC Input LOW ^(4,6,8)		—		$V_{REF} - 100$	mV
V_{REF}	Single-Ended Reference Voltage ^(4,8)		—	900	—	mV
Output Characteristics						
V_{OH}	Output HIGH Voltage	$I_{OH} = -8mA$	$V_{DDO} - 0.4$		—	V
		$I_{OH} = -100\mu A$	$V_{DDO} - 0.1$		—	V
V_{OL}	Output LOW Voltage	$I_{OL} = 8mA$	—		0.4	V
		$I_{OL} = 100\mu A$	—		0.1	V

NOTES:

- See RECOMMENDED OPERATING RANGE table.
- V_{DIF} specifies the minimum input differential voltage ($V_{TR} - V_{CP}$) required for switching where V_{TR} is the "true" input level and V_{CP} is the "complement" input level. Differential mode only. The DC differential voltage must be maintained to guarantee retaining the existing HIGH or LOW input. The AC differential voltage must be achieved to guarantee switching to a new state.
- V_{CM} specifies the maximum allowable range of $(V_{TR} + V_{CP}) / 2$. Differential mode only.
- For single-ended operation, in a differential mode, \bar{A}/V_{REF} is tied to the DC voltage V_{REF} .
- Voltage required to maintain a logic HIGH, single-ended operation in differential mode.
- Voltage required to maintain a logic LOW, single-ended operation in differential mode.
- Typical values are at $V_{DD} = 2.5V, V_{DDO} = 1.8V, +25^\circ C$ ambient.
- The reference clock input is capable of HSTL, eHSTL, LVEPECL, 1.8V or 2.5V LVTTTL operation independent of the device output. The correct input interface table should be referenced.
- For differential mode ($RxS = LOW$), A and \bar{A}/V_{REF} must be at the opposite rail.

POWER SUPPLY CHARACTERISTICS FOR eHSTL OUTPUTS⁽¹⁾

Symbol	Parameter	Test Conditions ⁽²⁾	Typ.	Max	Unit
I _{DDQ}	Quiescent V _{DD} Power Supply Current	V _{DDQ} = Max., Reference Clock = LOW ⁽³⁾ Outputs enabled. All outputs unloaded	20	30	mA
I _{DDOQ}	Quiescent V _{DDQ} Power Supply Current	V _{DDQ} = Max., Reference Clock = LOW ⁽³⁾ Outputs enabled. All outputs unloaded	0.1	0.3	mA
I _{DD}	Dynamic V _{DD} Power Supply Current per Output	V _{DD} = Max., V _{DDQ} = Max., C _L = 0pF	10	20	μA/MHz
I _{DDO}	Dynamic V _{DDQ} Power Supply Current per Output	V _{DD} = Max., V _{DDQ} = Max., C _L = 0pF	20	30	μA/MHz
I _{TOT}	Total Power V _{DD} Supply Current	V _{DDQ} = 1.8V, REFERENCE CLOCK = 100MHz, C _L = 15pF V _{DDQ} = 1.8V, REFERENCE CLOCK = 250MHz, C _L = 15pF	20 25	30 40	mA
I _{TOTQ}	Total Power V _{DDQ} Supply Current	V _{DDQ} = 1.8V, REFERENCE CLOCK = 100MHz, C _L = 15pF V _{DDQ} = 1.8V, REFERENCE CLOCK = 250MHz, C _L = 15pF	20 40	40 80	mA

NOTES:

1. These power consumption characteristics are for all the valid input interfaces and cover the worst case input and output interface combinations.
2. The termination resistors are excluded from these measurements.
3. If the differential input interface is used, the true input is held LOW and the complementary input is held HIGH.

DIFFERENTIAL INPUT AC TEST CONDITIONS FOR eHSTL

Symbol	Parameter	Value	Units
V _{DIF}	Input Signal Swing ⁽¹⁾	1	V
V _X	Differential Input Signal Crossing Point ⁽²⁾	900	mV
V _{THI}	Input Timing Measurement Reference Level ⁽³⁾	Crossing Point	V
t _R , t _F	Input Signal Edge Rate ⁽⁴⁾	1	V/ns

NOTES:

1. The 1V peak-to-peak input pulse level is specified to allow consistent, repeatable results in an automatic test equipment (ATE) environment. Compliant devices must meet the V_{DIF} (AC) specification under actual use conditions.
2. A 900mV crossing point level is specified to allow consistent, repeatable results in an automatic test equipment (ATE) environment. Compliant devices must meet the V_X specification under actual use conditions.
3. In all cases, input waveform timing is marked at the differential cross-point of the input signals.
4. The input signal edge rate of 1V/ns or greater is to be maintained in the 20% to 80% range of the input waveform.

DC ELECTRICAL CHARACTERISTICS OVER OPERATING RANGE FOR LVEPE-CL⁽¹⁾

Symbol	Parameter	Test Conditions	Min.	Typ. ⁽²⁾	Max	Unit
Input Characteristics						
I _{IH}	Input HIGH Current ⁽⁶⁾	V _{DD} = 2.6V V _I = V _{DDQ} /GND	—	—	±5	μA
I _{IL}	Input LOW Current ⁽⁶⁾	V _{DD} = 2.6V V _I = GND/V _{DDQ}	—	—	±5	μA
V _{IK}	Clamp Diode Voltage	V _{DD} = 2.4V, I _{IIN} = -18mA	—	-0.7	-1.2	V
V _{IN}	DC Input Voltage		-0.3	—	3.6	V
V _{CM}	DC Common Mode Input Voltage ^(3,5)		915	1082	1248	mV
V _{REF}	Single-Ended Reference Voltage ^(4,5)		—	1082	—	mV
V _{IH}	DC Input HIGH		1275	—	1620	mV
V _{IL}	DC Input LOW		555	—	875	mV

NOTES:

1. See RECOMMENDED OPERATING RANGE table.
2. Typical values are at V_{DD} = 2.5V, +25°C ambient.
3. V_{CM} specifies the maximum allowable range of (V_{TR} + V_{CP}) / 2. Differential mode only.
4. For single-ended operation while in differential mode, \bar{A}/V_{REF} is tied to the DC voltage V_{REF}.
5. The reference clock input is capable of HSTL, eHSTL, LVEPECL, 1.8V or 2.5V LVTTTL operation independent of the device output. The correct input interface table should be referenced.
6. For differential mode (R_XS = LOW), A and \bar{A}/V_{REF} must be at the opposite rail.

DIFFERENTIAL INPUT AC TEST CONDITIONS FOR LVEPECL

Symbol	Parameter	Value	Units
V _{DIF}	Input Signal Swing ⁽¹⁾	732	mV
V _X	Differential Input Signal Crossing Point ⁽²⁾	1082	mV
V _{THI}	Input Timing Measurement Reference Level ⁽³⁾	Crossing Point	V
t _R , t _F	Input Signal Edge Rate ⁽⁴⁾	1	V/ns

NOTES:

- The 732mV peak-to-peak input pulse level is specified to allow consistent, repeatable results in an automatic test equipment (ATE) environment. Compliant devices must meet the V_{DIF} (AC) specification under actual use conditions.
- A 1082mV crossing point level is specified to allow consistent, repeatable results in an automatic test equipment (ATE) environment. Compliant devices must meet the V_X specification under actual use conditions.
- In all cases, input waveform timing is marked at the differential cross-point of the input signals.
- The input signal edge rate of 1V/ns or greater is to be maintained in the 20% to 80% range of the input waveform.

DC ELECTRICAL CHARACTERISTICS OVER OPERATING RANGE FOR 2.5V LVTTTL⁽¹⁾

Symbol	Parameter	Test Conditions	Min.	Typ. ⁽⁸⁾	Max	Unit
Input Characteristics						
I _H	Input HIGH Current ⁽¹⁰⁾	V _{DD} = 2.6V V _I = V _{DDO} /GND	—	—	+5	μA
I _L	Input LOW Current ⁽¹⁰⁾	V _{DD} = 2.6V V _I = GND/V _{DDO}	—	—	+5	μA
V _{IK}	Clamp Diode Voltage	V _{DD} = 2.4V, I _{IN} = -18mA	—	-0.7	-1.2	V
V _{IN}	DC Input Voltage		-0.3		+3.6	V
Single-Ended Inputs ⁽²⁾						
V _{IH}	DC Input HIGH		1.7		—	V
V _{IL}	DC Input LOW		—		0.7	V
Differential Inputs						
V _{DIF}	DC Differential Voltage ^(3,9)		0.2		—	V
V _{CM}	DC Common Mode Input Voltage ^(4,9)		1150	1250	1350	mV
V _{IH}	DC Input HIGH ^(5,6,9)		V _{REF} + 100		—	mV
V _{IL}	DC Input LOW ^(5,7,9)		—		V _{REF} - 100	mV
V _{REF}	Single-Ended Reference Voltage ^(5,9)		—	1250	—	mV
Output Characteristics						
V _{OH}	Output HIGH Voltage	I _{OH} = -12mA	V _{DDO} - 0.4		—	V
		I _{OH} = -100μA	V _{DDO} - 0.1		—	V
V _{OL}	Output LOW Voltage	I _{OL} = 12mA	—		0.4	V
		I _{OL} = 100μA	—		0.1	V

NOTES:

- See RECOMMENDED OPERATING RANGE table.
- For 2.5V LVTTTL single-ended operation, the RxS pin is tied HIGH and \bar{A}/V_{REF} is tied to GND.
- V_{DIF} specifies the minimum input differential voltage (V_{TR} - V_{CP}) required for switching where V_{TR} is the "true" input level and V_{CP} is the "complement" input level. Differential mode only. The DC differential voltage must be maintained to guarantee retaining the existing HIGH or LOW input. The AC differential voltage must be achieved to guarantee switching to a new state.
- V_{CM} specifies the maximum allowable range of (V_{TR} + V_{CP}) / 2. Differential mode only.
- For single-ended operation, in differential mode, \bar{A}/V_{REF} is tied to the DC voltage V_{REF}.
- Voltage required to maintain a logic HIGH, single-ended operation in differential mode.
- Voltage required to maintain a logic LOW, single-ended operation in differential mode.
- Typical values are at V_{DD} = 2.5V, V_{DDO} = V_{DD}, +25°C ambient.
- The reference clock input is capable of HSTL, eHSTL, LVEPECL, 1.8V or 2.5V LVTTTL operation independent of the device output. The correct input interface table should be referenced.
- For differential mode (RxS = LOW), A and \bar{A}/V_{REF} must be at the opposite rail.

POWER SUPPLY CHARACTERISTICS FOR 2.5V LVTTTL OUTPUTS⁽¹⁾

Symbol	Parameter	Test Conditions ⁽²⁾	Typ.	Max	Unit
I _{DDQ}	Quiescent V _{DD} Power Supply Current	V _{DDQ} = Max., Reference Clock = LOW ⁽³⁾ Outputs enabled. All outputs unloaded	20	30	mA
I _{DDQQ}	Quiescent V _{DDQ} Power Supply Current	V _{DDQ} = Max., Reference Clock = LOW ⁽³⁾ Outputs enabled. All outputs unloaded	0.1	0.3	mA
I _{DD}	Dynamic V _{DD} Power Supply Current per Output	V _{DD} = Max., V _{DDQ} = Max., C _L = 0pF	15	20	μA/MHz
I _{DDQ}	Dynamic V _{DDQ} Power Supply Current per Output	V _{DD} = Max., V _{DDQ} = Max., C _L = 0pF	30	40	μA/MHz
I _{TOT}	Total Power V _{DD} Supply Current	V _{DDQ} = 2.5V, F _{REFERENCE CLOCK} = 100MHz, C _L = 15pF	20	40	mA
		V _{DDQ} = 2.5V, F _{REFERENCE CLOCK} = 200MHz, C _L = 15pF	30	50	
I _{TOTQ}	Total Power V _{DDQ} Supply Current	V _{DDQ} = 2.5V, F _{REFERENCE CLOCK} = 100MHz, C _L = 15pF	30	50	mA
		V _{DDQ} = 2.5V, F _{REFERENCE CLOCK} = 200MHz, C _L = 15pF	70	100	

NOTES:

1. These power consumption characteristics are for all the valid input interfaces and cover the worst case input and output interface combinations.
2. The termination resistors are excluded from these measurements.
3. If the differential input interface is used, the true input is held LOW and the complementary input is held HIGH.

DIFFERENTIAL INPUT AC TEST CONDITIONS FOR 2.5V LVTTTL

Symbol	Parameter	Value	Units
V _{DIF}	Input Signal Swing ⁽¹⁾	V _{DD}	V
V _X	Differential Input Signal Crossing Point ⁽²⁾	V _{DD} /2	V
V _{THI}	Input Timing Measurement Reference Level ⁽³⁾	Crossing Point	V
t _R , t _F	Input Signal Edge Rate ⁽⁴⁾	2.5	V/ns

NOTES:

1. A nominal 2.5V peak-to-peak input pulse level is specified to allow consistent, repeatable results in an automatic test equipment (ATE) environment. Compliant devices must meet the V_{DIF} (AC) specification under actual use conditions.
2. A nominal 1.25V crossing point level is specified to allow consistent, repeatable results in an automatic test equipment (ATE) environment. Compliant devices must meet the V_X specification under actual use conditions.
3. In all cases, input waveform timing is marked at the differential cross-point of the input signals.
4. The input signal edge rate of 2.5V/ns or greater is to be maintained in the 20% to 80% range of the input waveform.

SINGLE-ENDED INPUT AC TEST CONDITIONS FOR 2.5V LVTTTL

Symbol	Parameter	Value	Units
V _{IH}	Input HIGH Voltage	V _{DD}	V
V _{IL}	Input LOW Voltage	0	V
V _{THI}	Input Timing Measurement Reference Level ⁽¹⁾	V _{DD} /2	V
t _R , t _F	Input Signal Edge Rate ⁽²⁾	2	V/ns

NOTES:

1. A nominal 1.25V timing measurement reference level is specified to allow constant, repeatable results in an automatic test equipment (ATE) environment.
2. The input signal edge rate of 2V/ns or greater is to be maintained in the 10% to 90% range of the input waveform.

DC ELECTRICAL CHARACTERISTICS OVER OPERATING RANGE FOR 1.8V LVTTTL⁽¹⁾

Symbol	Parameter	Test Conditions	Min.	Typ. ⁽⁸⁾	Max	Unit
Input Characteristics						
I_{IH}	Input HIGH Current ⁽¹²⁾	$V_{DD} = 2.6V$ $V_I = V_{DDQ}/GND$	—	—	± 5	μA
I_{IL}	Input LOW Current ⁽¹²⁾	$V_{DD} = 2.6V$ $V_I = GND/V_{DDQ}$	—	—	± 5	
V_{IK}	Clamp Diode Voltage	$V_{DD} = 2.4V$, $I_{IN} = -18mA$	—	-0.7	-1.2	V
V_{IN}	DC Input Voltage		-0.3		$V_{DDQ} + 0.3$	V
Single-Ended Inputs ⁽²⁾						
V_{IH}	DC Input HIGH		1.073 ⁽¹⁰⁾		—	V
V_{IL}	DC Input LOW		—		0.683 ⁽¹¹⁾	V
Differential Inputs						
V_{DIF}	DC Differential Voltage ^(3,9)		0.2		—	V
V_{CM}	DC Common Mode Input Voltage ^(4,9)		825	900	975	mV
V_{IH}	DC Input HIGH ^(5,6,9)		$V_{REF} + 100$		—	mV
V_{IL}	DC Input LOW ^(5,7,9)		—		$V_{REF} - 100$	mV
V_{REF}	Single-Ended Reference Voltage ^(5,9)		—	900	—	mV
Output Characteristics						
V_{OH}	Output HIGH Voltage	$I_{OH} = -6mA$	$V_{DDQ} - 0.4$		—	V
		$I_{OH} = -100\mu A$	$V_{DDQ} - 0.1$		—	V
V_{OL}	Output LOW Voltage	$I_{OL} = 6mA$	—		0.4	V
		$I_{OL} = 100\mu A$	—		0.1	V

NOTES:

- See RECOMMENDED OPERATING RANGE table.
- For 1.8V LVTTTL single-ended operation, the RxS pin is allowed to float or tied to $V_{DD}/2$ and \bar{A}/V_{REF} is tied to GND.
- V_{DIF} specifies the minimum input differential voltage ($V_{TR} - V_{CP}$) required for switching where V_{TR} is the "true" input level and V_{CP} is the "complement" input level. Differential mode only. The DC differential voltage must be maintained to guarantee retaining the existing HIGH or LOW input. The AC differential voltage must be achieved to guarantee switching to a new state.
- V_{CM} specifies the maximum allowable range of $(V_{TR} + V_{CP})/2$. Differential mode only.
- For single-ended operation in differential mode, \bar{A}/V_{REF} is tied to the DC voltage V_{REF} . The input is guaranteed to toggle within $\pm 200mV$ of V_{REF} when V_{REF} is constrained within $+600mV$ and $V_{DDI}-600mV$, where V_{DDI} is the nominal 1.8V power supply of the device driving the A input. To guarantee switching in voltage range specified in the JEDEC 1.8V LVTTTL interface specification, V_{REF} must be maintained at 900mV with appropriate tolerances.
- Voltage required to maintain a logic HIGH, single-ended operation in differential mode.
- Voltage required to maintain a logic LOW, single-ended operation in differential mode.
- Typical values are at $V_{DD} = 2.5V$, $V_{DDQ} = 1.8V$, $+25^\circ C$ ambient.
- The reference clock input is capable of HSTL, eHSTL, LVEPECL, 1.8V or 2.5V LVTTTL operation independent of the device output. The correct input interface table should be referenced.
- This value is the worst case minimum V_{IH} over the specification range of the 1.8V power supply. The 1.8V LVTTTL specification is $V_{IH} = 0.65 \cdot V_{DD}$ where V_{DD} is $1.8V \pm 0.15V$. However, the LVTTTL translator is supplied by a 2.5V nominal supply on this part. To ensure compliance with the specification, the translator was designed to accept the calculated worst case value ($V_{IH} = 0.65 \cdot [1.8 - 0.15V]$) rather than reference against a nominal 1.8V supply.
- This value is the worst case maximum V_{IL} over the specification range of the 1.8V power supply. The 1.8V LVTTTL specification is $V_{IL} = 0.35 \cdot V_{DD}$ where V_{DD} is $1.8V \pm 0.15V$. However, the LVTTTL translator is supplied by a 2.5V nominal supply on this part. To ensure compliance with the specification, the translator was designed to accept the calculated worst case value ($V_{IL} = 0.35 \cdot [1.8 + 0.15V]$) rather than reference against a nominal 1.8V supply.
- For differential mode ($RxS = LOW$), A and \bar{A}/V_{REF} must be at the opposite rail.

POWER SUPPLY CHARACTERISTICS FOR 1.8V LVTTTL OUTPUTS⁽¹⁾

Symbol	Parameter	Test Conditions ⁽²⁾	Typ.	Max	Unit
I _{DDQ}	Quiescent V _{DD} Power Supply Current	V _{DDQ} = Max., Reference Clock = LOW ⁽³⁾ Outputs enabled. All outputs unloaded	20	30	mA
I _{DDQQ}	Quiescent V _{DDQ} Power Supply Current	V _{DDQ} = Max., Reference Clock = LOW ⁽³⁾ Outputs enabled. All outputs unloaded	0.1	0.3	mA
I _{DD}	Dynamic V _{DD} Power Supply Current per Output	V _{DD} = Max., V _{DDQ} = Max., C _L = 0pF	20	30	μA/MHz
I _{DDQ}	Dynamic V _{DDQ} Power Supply Current per Output	V _{DD} = Max., V _{DDQ} = Max., C _L = 0pF	20	30	μA/MHz
I _{TOT}	Total Power V _{DD} Supply Current	V _{DDQ} = 1.8V, F _{REFERENCE CLOCK} = 100MHz, C _L = 15pF	20	30	mA
		V _{DDQ} = 1.8V, F _{REFERENCE CLOCK} = 200MHz, C _L = 15pF	30	40	
I _{TOTQ}	Total Power V _{DDQ} Supply Current	V _{DDQ} = 1.8V, F _{REFERENCE CLOCK} = 100MHz, C _L = 15pF	20	40	mA
		V _{DDQ} = 1.8V, F _{REFERENCE CLOCK} = 200MHz, C _L = 15pF	45	80	

NOTES:

1. These power consumption characteristics are for all the valid input interfaces and cover the worst case input and output interface combinations.
2. The termination resistors are excluded from these measurements.
3. If the differential input interface is used, the true input is held LOW and the complementary input is held HIGH.

DIFFERENTIAL INPUT AC TEST CONDITIONS FOR 1.8V LVTTTL

Symbol	Parameter	Value	Units
V _{DIF}	Input Signal Swing ⁽¹⁾	V _{DDI}	V
V _X	Differential Input Signal Crossing Point ⁽²⁾	V _{DDI} /2	mV
V _{THI}	Input Timing Measurement Reference Level ⁽³⁾	Crossing Point	V
t _R , t _F	Input Signal Edge Rate ⁽⁴⁾	1.8	V/ns

NOTES:

1. V_{DDI} is the nominal 1.8V supply (1.8V ± 0.15V) of the part or source driving the input. A nominal 1.8V peak-to-peak input pulse level is specified to allow consistent, repeatable results in an automatic test equipment (ATE) environment. Compliant devices must meet the V_{DIF} (AC) specification under actual use conditions.
2. A nominal 900mV crossing point level is specified to allow consistent, repeatable results in an automatic test equipment (ATE) environment. Compliant devices must meet the V_X specification under actual use conditions.
3. In all cases, input waveform timing is marked at the differential cross-point of the input signals.
4. The input signal edge rate of 1.8V/ns or greater is to be maintained in the 20% to 80% range of the input waveform.

SINGLE-ENDED INPUT AC TEST CONDITIONS FOR 1.8V LVTTTL

Symbol	Parameter	Value	Units
V _{IH}	Input HIGH Voltage ⁽¹⁾	V _{DDI}	V
V _{IL}	Input LOW Voltage	0	V
V _{THI}	Input Timing Measurement Reference Level ⁽²⁾	V _{DDI} /2	mV
t _R , t _F	Input Signal Edge Rate ⁽³⁾	2	V/ns

NOTES:

1. V_{DDI} is the nominal 1.8V supply (1.8V ± 0.15V) of the part or source driving the input.
2. A nominal 900mV timing measurement reference level is specified to allow constant, repeatable results in an automatic test equipment (ATE) environment.
3. The input signal edge rate of 2V/ns or greater is to be maintained in the 10% to 90% range of the input waveform.

AC ELECTRICAL CHARACTERISTICS OVER OPERATING RANGE⁽⁶⁾

Symbol	Parameter	Min.	Typ.	Max	Unit
--------	-----------	------	------	-----	------

Skew Parameters

tsk(o)	Same Device Output Pin-to-Pin Skew ⁽¹⁾	Single-Ended and Differential Modes	—	—	25	ps
		Single-Ended in Differential Mode (DSE)	—	25	—	
tsk(p) ⁽²⁾	Pulse Skew ⁽³⁾	Single-Ended and Differential Modes	—	—	300	ps
		Single-Ended in Differential Mode (DSE)	—	300	—	
dt ⁽⁴⁾	Duty Cycle	40	—	60	%	
tsk(pp)	Part-to-Part Skew ⁽⁵⁾	Single-Ended and Differential Modes	—	—	300	ps
		Single-Ended in Differential Mode (DSE)	—	300	—	

Propagation Delay

t _{PLH}	Propagation Delay A to Qn		—	—	2.5	ns
t _{PHL}			—	—	—	—
tr	Output Rise Time (20% to 80%)	2.5V / 1.8V LVTTTL Outputs	350	—	1050	ps
		HSTL / eHSTL Outputs	350	—	1350	
tf	Output Fall Time (20% to 80%)	2.5V / 1.8V LVTTTL Outputs	350	—	1050	ps
		HSTL / eHSTL Outputs	350	—	1350	
fo	Frequency Range (HSTL/eHSTL outputs)		—	—	250	MHz
	Frequency Range (2.5V/1.8V LVTTTL outputs)		—	—	200	

Output Gate Enable/Disable Delay

t _{PGE}	Output Gate Enable to Qn	—	—	3.5	ns
t _{PGD}	Output Gate Enable to Qn Driven to GL Designated Level	—	—	3	ns

NOTES:

1. Skew measured between all outputs under identical input and output interfaces, transitions, and load conditions on any one device.
2. For only 1.8V/2.5V LVTTTL and eHSTL outputs.
3. Skew measured is difference between propagation times t_{PLH} and t_{PHL} of any output under identical input and output interfaces, transitions, and load conditions on any one device.
4. For only HSTL outputs.
5. Skew measured is the magnitude of the difference in propagation times between any outputs of two devices, given identical transitions and load conditions at identical V_{DD}/V_{DD0} levels and temperature.
6. Guaranteed by design.

AC DIFFERENTIAL INPUT SPECIFICATIONS⁽¹⁾

Symbol	Parameter	Min.	Typ.	Max	Unit
t _w	Reference Clock Pulse Width HIGH or LOW (HSTL/eHSTL outputs) ⁽²⁾	1.73	—	—	ns
	Reference Clock Pulse Width HIGH or LOW (2.5V / 1.8V LVTTTL outputs) ⁽²⁾	2.17	—	—	

HSTL/eHSTL/1.8V LVTTTL/2.5V LVTTTL

V _{DIF}	AC Differential Voltage ⁽³⁾	400	—	—	mV
V _{IH}	AC Input HIGH ^(4,5)	V _X + 200	—	—	mV
V _{IL}	AC Input LOW ^(4,6)	—	—	V _X - 200	mV

LVEPECL

V _{DIF}	AC Differential Voltage ⁽³⁾	400	—	—	mV
V _{IH}	AC Input HIGH ⁽⁴⁾	1275	—	—	mV
V _{IL}	AC Input LOW ⁽⁴⁾	—	—	875	mV

NOTES:

- For differential input mode, RxS is tied to GND.
- Both differential input signals should not be driven to the same level simultaneously. The input will not change state until the inputs have crossed and the voltage range defined by V_{DIF} has been met or exceeded.
- Differential mode only. V_{DIF} specifies the minimum input voltage (V_{TR} - V_{CP}) required for switching where V_{TR} is the "true" input level and V_{CP} is the "complement" input level. The AC differential voltage must be achieved to guarantee switching to a new state.
- For single-ended operation, \bar{A}/V_{REF} is tied to DC voltage (V_{REF}). Refer to each input interface's DC specification for the correct V_{REF} range.
- Voltage required to switch to a logic HIGH, single-ended operation only.
- Voltage required to switch to a logic LOW, single-ended operation only.

AC TIMING WAVEFORMS

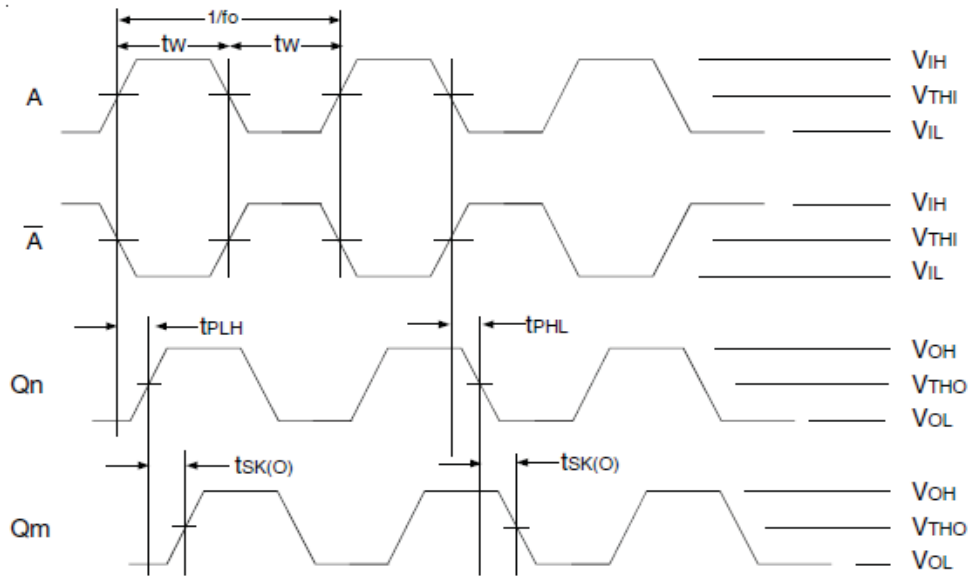

Propagation and Skew Waveforms

NOTES:

1. t_{PHL} and t_{PLH} signals are measured from the input passing through V_{THI} or input pair crossing to Qn passing through V_{THO} .
2. Pulse Skew is calculated using the following expression:

$$t_{sk(P)} = |t_{PHL} - t_{PLH}|$$

where t_{PHL} and t_{PLH} are measured on the controlled edges of any one output from rising and falling edges of a single pulse. Please note that the t_{PHL} and t_{PLH} shown are not valid measurements for this calculation because they are not taken from the same pulse.

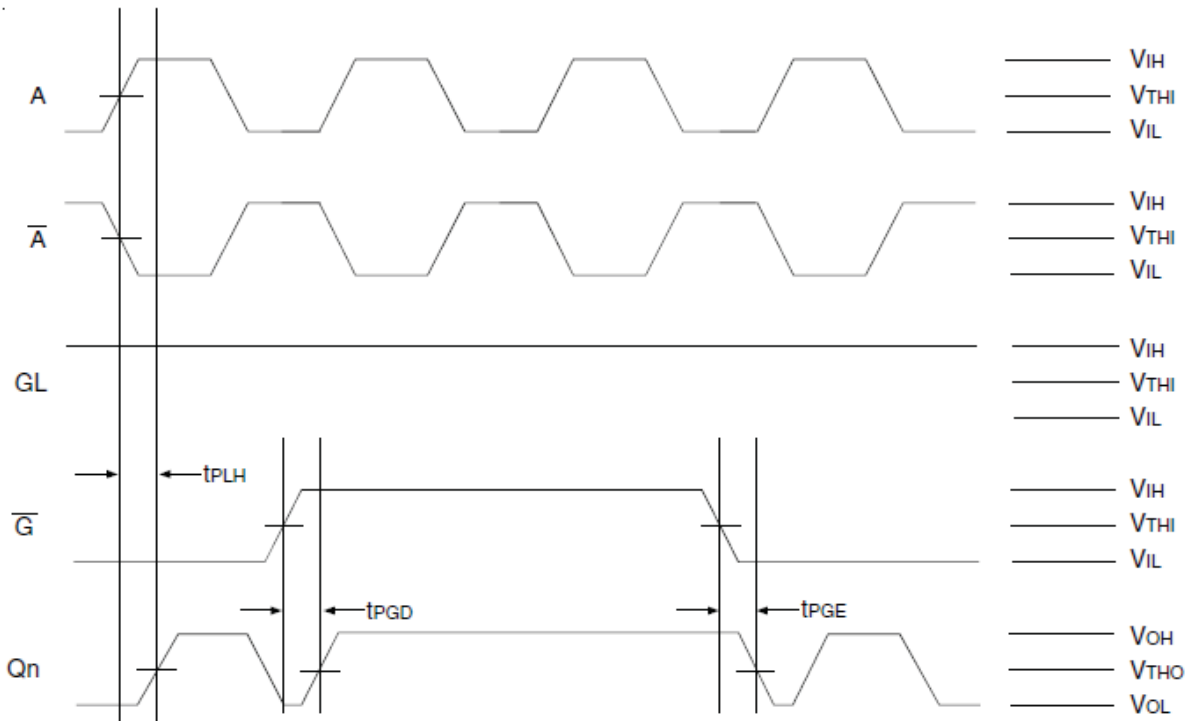

Gate Disable/Enable Showing Runt Pulse Generation

NOTE:

As shown, it is possible to generate runt pulses on gate disable and enable of the outputs. It is the user's responsibility to time their \bar{G}_X signals to avoid this problem.

TEST CIRCUITS AND CONDITIONS

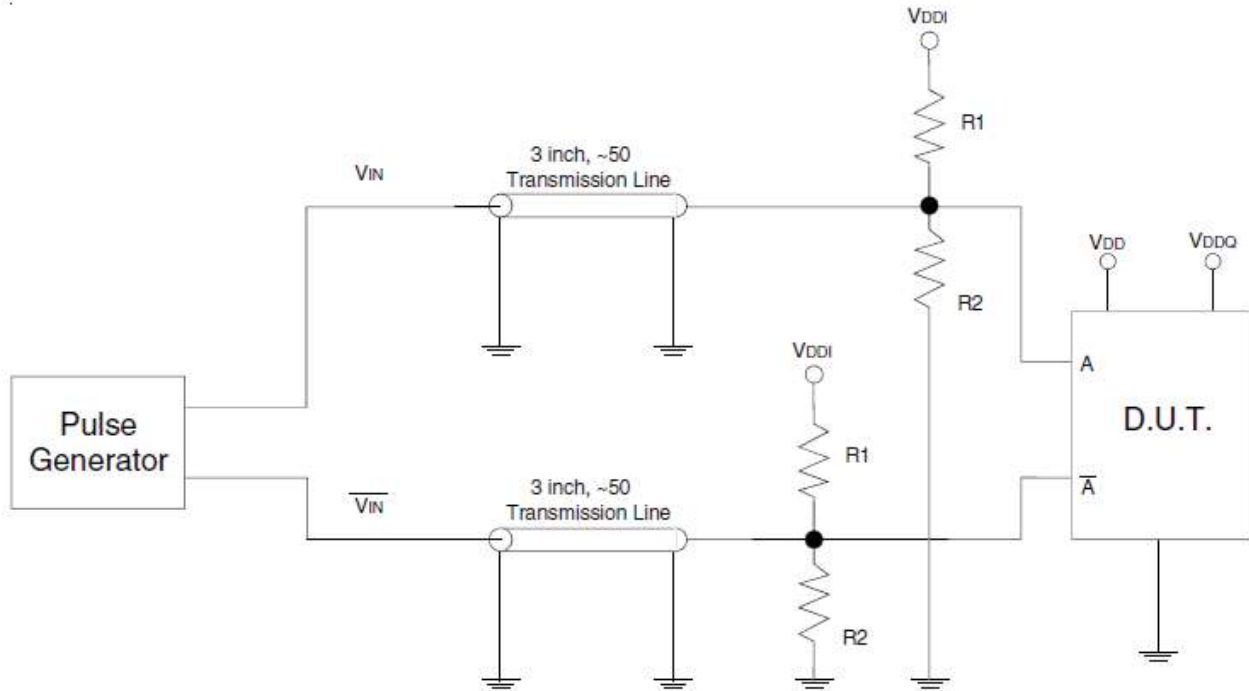

Test Circuit for Differential Input⁽¹⁾

DIFFERENTIAL INPUT TEST CONDITIONS

Symbol	$V_{DD} = 2.5V \pm 0.1V$	Unit
R1	100	Ω
R2	100	Ω
V_{DDI}	$V_{CM} * 2$	V
V_{THI}	HSTL: Crossing of A and \overline{A} eHSTL: Crossing of A and \overline{A} LVEPECL: Crossing of A and \overline{A} 1.8V LVTTTL: $V_{DDI}/2$ 2.5V LVTTTL: $V_{DD}/2$	V

NOTE:

1. This input configuration is used for all input interfaces. For single-ended testing, the V_{IN} input is tied to GND. For testing single-ended in differential input mode, the V_{IN} is left floating.

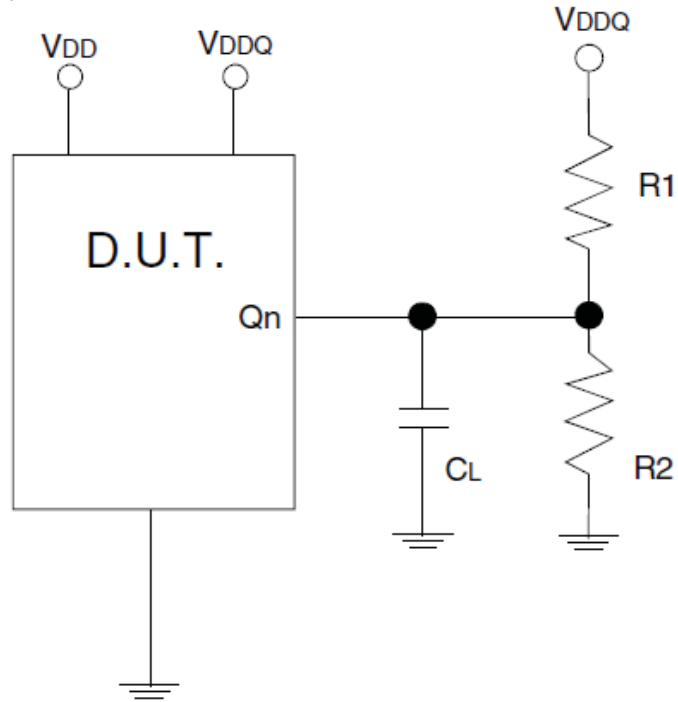

Test Circuit for SDR Outputs

SDR OUTPUT TEST CONDITIONS

Symbol	$V_{DD} = 2.5V \pm 0.1V$ $V_{DDQ} = \text{Interface Specified}$	Unit
C_L	15	pF
R1	100	Ω
R2	100	Ω
V_{TH0}	$V_{DDQ} / 2$	V

REVISION HISTORY

Rev	Table	Page	Discription of Change	Date
A		1	NRND - Not Recommended for New Designs	5/5/13
A		1	Product Discontinuation Notice - Last time buy expires November 2, 2016 PDN # CQ-15-05	

IMPORTANT NOTICE AND DISCLAIMER

RENESAS ELECTRONICS CORPORATION AND ITS SUBSIDIARIES (“RENESAS”) PROVIDES TECHNICAL SPECIFICATIONS AND RELIABILITY DATA (INCLUDING DATASHEETS), DESIGN RESOURCES (INCLUDING REFERENCE DESIGNS), APPLICATION OR OTHER DESIGN ADVICE, WEB TOOLS, SAFETY INFORMATION, AND OTHER RESOURCES “AS IS” AND WITH ALL FAULTS, AND DISCLAIMS ALL WARRANTIES, EXPRESS OR IMPLIED, INCLUDING, WITHOUT LIMITATION, ANY IMPLIED WARRANTIES OF MERCHANTABILITY, FITNESS FOR A PARTICULAR PURPOSE, OR NON-INFRINGEMENT OF THIRD PARTY INTELLECTUAL PROPERTY RIGHTS.

These resources are intended for developers skilled in the art designing with Renesas products. You are solely responsible for (1) selecting the appropriate products for your application, (2) designing, validating, and testing your application, and (3) ensuring your application meets applicable standards, and any other safety, security, or other requirements. These resources are subject to change without notice. Renesas grants you permission to use these resources only for development of an application that uses Renesas products. Other reproduction or use of these resources is strictly prohibited. No license is granted to any other Renesas intellectual property or to any third party intellectual property. Renesas disclaims responsibility for, and you will fully indemnify Renesas and its representatives against, any claims, damages, costs, losses, or liabilities arising out of your use of these resources. Renesas' products are provided only subject to Renesas' Terms and Conditions of Sale or other applicable terms agreed to in writing. No use of any Renesas resources expands or otherwise alters any applicable warranties or warranty disclaimers for these products.

(Disclaimer Rev.1.0 Mar 2020)

Corporate Headquarters

TOYOSU FORESIA, 3-2-24 Toyosu,
Koto-ku, Tokyo 135-0061, Japan
www.renesas.com

Contact Information

For further information on a product, technology, the most up-to-date version of a document, or your nearest sales office, please visit:
www.renesas.com/contact/

Trademarks

Renesas and the Renesas logo are trademarks of Renesas Electronics Corporation. All trademarks and registered trademarks are the property of their respective owners.