

Features

- Full Wave Current Sensing
- Compensated Mains Supply Variations
- Variable Soft Start or Load-current Sensing
- Voltage and Current Synchronization
- Switchable Automatic Retriggering
- Triggering Pulse Typically 125 mA
- Internal Supply-voltage Monitoring
- Current Requirement ≤ 3 mA

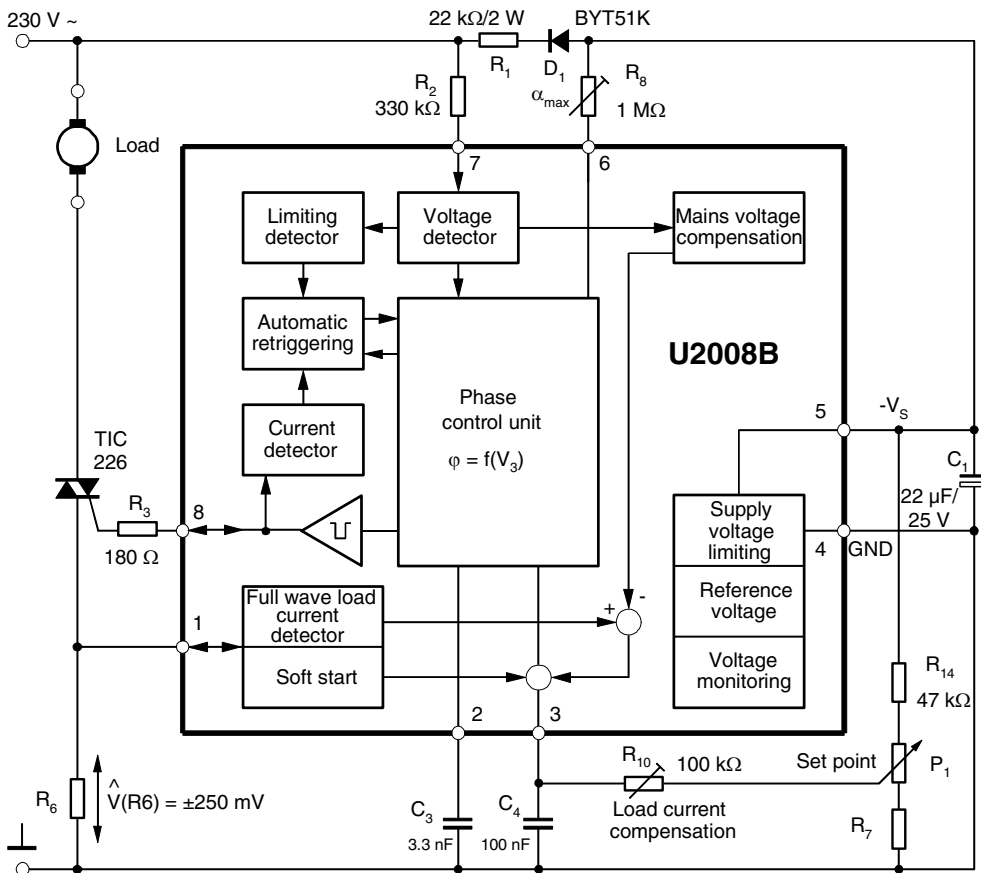
Applications

- Low-cost Motor Control
- Domestic Appliance

Description

The U2008B is designed as a phase-control circuit in bipolar technology. It enables load-current detection as well as mains-compensated phase control. Motor control with load-current feedback and overload protection are preferred applications.

Figure 1. Block Diagram with Typical Circuit: Load Current Sensing

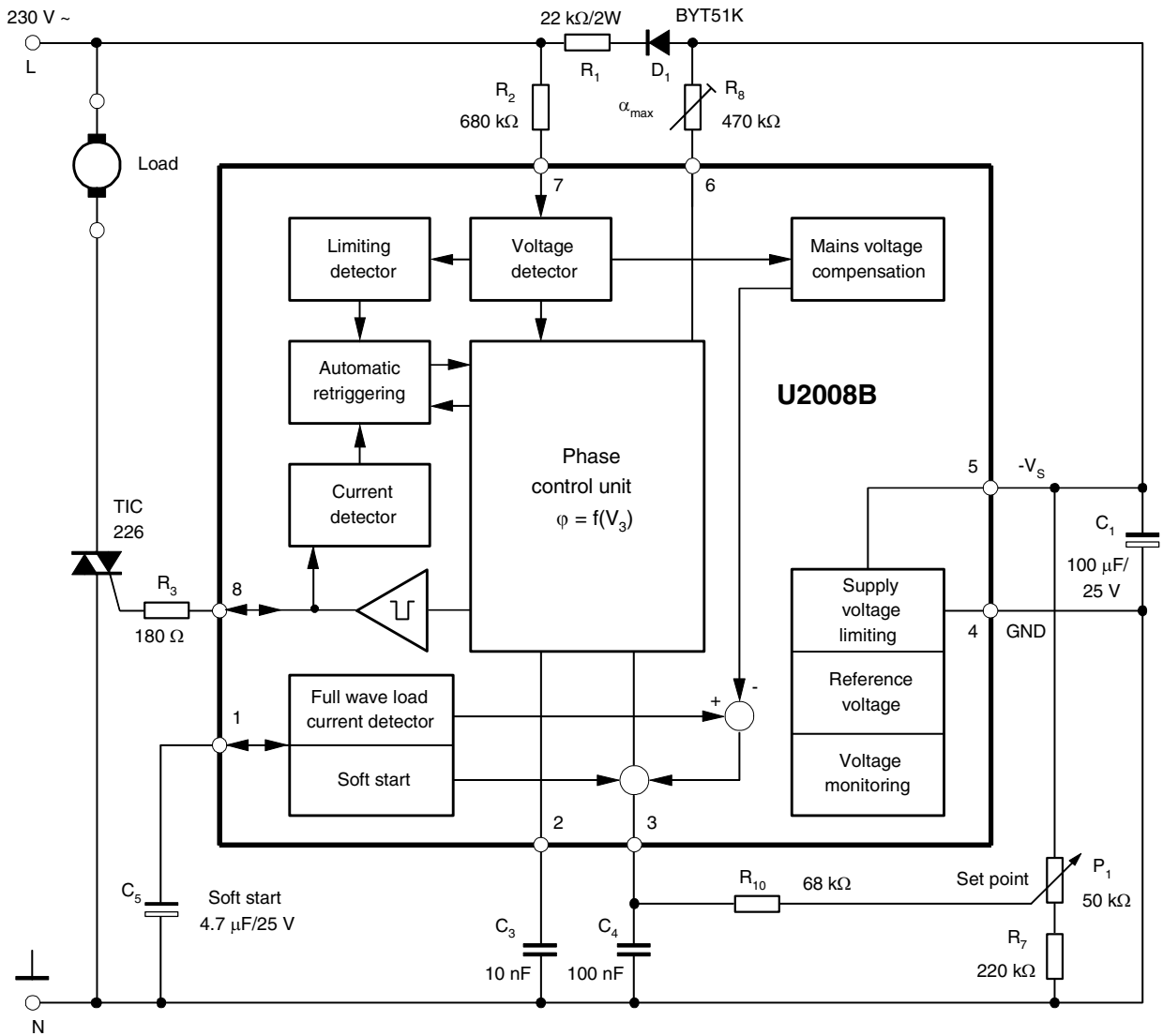


Low-cost Phase-control IC with Soft Start

U2008B

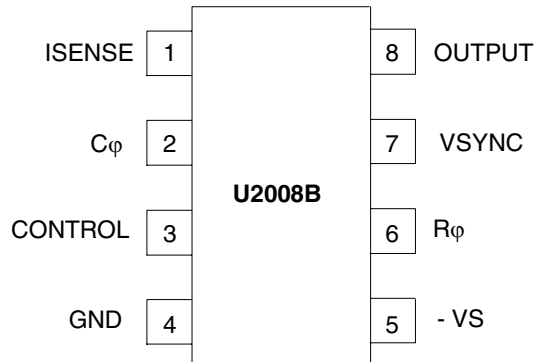


Figure 2. Block Diagram with Typical Circuit: Soft Start



Pin Configuration

Figure 3. Pinning



Pin Description

Pin	Symbol	Function
1	ISENSE	Load current sensing
2	C ϕ	Ramp voltage
3	CONTROL	Control input/compensation output
4	GND	Ground
5	-VS	Supply voltage
6	R ϕ	Ramp current adjustment
7	VSYNC	Voltage synchronization
8	OUTPUT	Trigger output

Mains Supply, Pin 5, Figure 2

The integrated circuit U2008B, which also contains voltage limiting, can be connected via D₁ and R₁ to the mains supply. Supply voltage, between Pin 4 (pos., ⊥) and Pin 5, is smoothed by C₁.

The series resistance R1 can be calculated as follows:

$$R_{1\max} = 0.85 \times \frac{V_M - V_{S\max}}{2 \times I_{\text{tot}}}$$

where:

- V_M = Mains voltage
- V_{Smax} = Maximum supply voltage
- I_{tot} = I_{Smax} + I_x = Total current consumption
- I_{Smax} = Maximum current consumption of the IC
- I_x = Current consumption of the external components

Operation with externally stabilized DC voltage is not recommended.

Voltage Monitoring

When the voltage is built up, uncontrolled output pulses are avoided by internal voltage monitoring. Apart from that, all latches of the circuit (phase control, load limit regulation) are reset and the soft start capacitor is short circuited. This guarantees a specified start-up behavior each time the supply voltage is switched on or after short interruptions of the mains supply. Soft start is initiated after the supply voltage has been built up. This behavior guarantees a gentle start-up for the motor and automatically ensures the optimum run-up time.

Phase Control, Pin 6

The function of the phase control is identical to that of the well-known IC U211B. The phase angle of the trigger pulse is derived by comparing the ramp voltage V_2 at Pin 2 with the set value on the control input, Pin 3. The slope of the ramp is determined by C_3 and its charging current I_φ .

The charging current can be regulated, changed or altered using R_8 at Pin 6. The maximum phase angle, α_{\max} , (minimum current flow angle φ_{\min}) can also be adjusted by using R_8 (see Figure 5).

When the potential on Pin 2 reaches the set point level of Pin 3, a trigger pulse is generated whose pulse width, t_p , is determined from the value of C_3 ($t_p = 9 \mu\text{s/nF}$, see Figure 7). At the same time, a latch is set with the output pulse, as long as the automatic retriggering has not been activated, then no more pulses can be generated in that half cycle. Control input at Pin 3 (with respect to Pin 4) has an active range from -9 V to -2 V. When $V_3 = -9 \text{ V}$ the phase angle is at its maximum α_{\max} , i.e., the current flow angle is minimum. The minimum phase angle α_{\min} is set with $V_3 \geq -1 \text{ V}$.

Automatic Retriggering

The current-detector circuit monitors the state of the triac after triggering by measuring the voltage drop at the triac gate. A current flow through the triac is recognized when the voltage drop exceeds a threshold level of typically 40 mV.

If the triac is quenched within the relevant half wave after triggering (for example owing to low load currents before or after the zero crossing of current wave, or for commutator motors, owing to brush lifters), the automatic retriggering circuit ensures immediate retriggering, if necessary with a high repetition rate, t_{pp}/t_p , until the triac remains reliably triggered.

Current Synchronization, Pin 8

Current synchronization fulfils two functions:

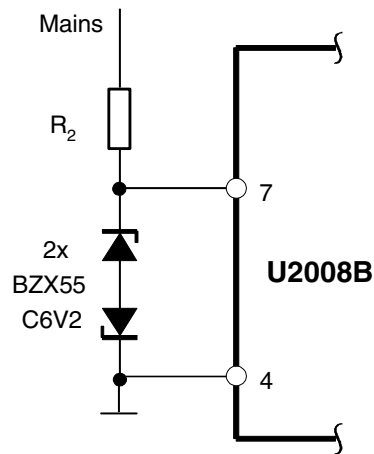
- Monitoring the current flow after triggering. In case the triac extinguishes again or it does not switch on, automatic triggering is activated as long as triggering is successful.
- Avoiding triggering due to inductive load. In the case of inductive load operation, the current synchronization ensures that in the new half wave no pulse is enabled as long as there is a current available from the previous half wave, which flows from the opposite polarity to the actual supply voltage.

A special feature of the IC is the realization of current synchronization. The device evaluates the voltage at the pulse output between the gate and reference electrode of the triac. This results in saving the separate current synchronization input with specified series resistance.

Voltage Synchronization with Mains Voltage Compensation, Pin 7

The voltage detector synchronizes the reference ramp with the mains supply voltage. At the same time, the mains-dependent input current at Pin 7 is shaped and rectified internally. This current activates automatic retriggering and at the same time is available at Pin 3 (see Figure 9). By suitable dimensioning, it is possible to attain the specified compensation effect. Automatic retriggering and mains voltage compensation are not activated until $|V_7 - V_4|$ increases to 8 V. The resistance R_{sync} defines the width of the zero voltage cross-over pulse, synchronization current, and hence the mains supply voltage compensation current. If the mains voltage compensation and the automatic retriggering are not required, both functions can be suppressed by limiting $|V_7 - V_4| \leq 7$ V (see Figure 4).

Figure 4. Suppression of Automatic Retriggering and Mains Voltage Compensation



A further feature of the IC is the selection between soft start and load-current compensation. Soft start is possible by connecting a capacitor between Pin 1 and Pin 4 (see Figure 8). In the case of load-current compensation, Pin 1 is directly connected with resistance R_6 , which is used for sensing load current.

Load Current Detection, Pin 1

The circuit continuously measures the load current as a voltage drop at resistor R_6 . The evaluation and use of both half waves results in a quick reaction to load-current change. Due to voltage at resistor R_6 , there is an increase of input current at Pin 1. This current increase controls the internal current source, whose positive current values are available at Pin 3 (see Figure 11). The output current generated at Pin 3 contains the difference from the load-current detection and the mains-voltage compensation (see Figure 9).

The effective control voltage is the final current at Pin 3 together with the desired value network. An increase of mains voltage causes an increase of the control angle α . An increase of load current results in a decrease of the control angle. This avoids a decrease in revolution by increasing the load as well as an increase of revolution by the increment of mains supply voltage.

Absolute Maximum Ratings

$V_S = 14\text{ V}$, reference point Pin 4, unless otherwise specified

Parameters	Symbol	Value	Unit
Current limitation Pin 5 $t \leq 10\ \mu\text{s}$	$-I_S$	30	mA
	$-i_S$	100	mA
Synchronous currents Pin 7 $t \leq 10\ \mu\text{s}$	$\pm I_{\text{syncV}}$	5	mA
	$\pm i_{\text{syncV}}$	20	mA
Phase Control Pin 3			
Control voltage	$-V_I$	V_S to 0	V
Input current	$\pm I_I$	500	mA
Charge current Pin 6	$-I_{\phi\text{max}}$	0.5	mA
Load Current Monitoring/Soft Start, Pin 1			
Input current	I_I	1	mA
Input voltage	V_I	$-V_S$ to +2	V
Pulse output			
Input voltage Pin 8	$+V_I$	2	V
	$-V_I$	V_S	V
Storage temperature range	T_{stg}	-40 to +125	°C
Junction temperature range	T_J	-10 to +125	°C

Thermal Resistance

Parameters		Symbol	Value	Unit
Junction ambient	DIP8	R_{thJA}	110	K/W
	SO8 on p.c.	R_{thJA}	220	K/W
	So8 on ceramic	R_{thJA}	140	K/W

Electrical Characteristics

Parameters	Test Conditions	Symbol	Min.	Typ.	Max.	Unit
Supply (Pin 5)						
Supply-voltage limitation	$-I_S = 3.5 \text{ mA}$	$-V_S$	14.5		16.5	V
	$-I_S = 30 \text{ mA}$	$-V_S$	14.6		16.8	V
Current requirement	Pins 1, 4 and 7 open	$-I_S$			3.0	mA
Voltage Monitoring (Pin 5)						
Turn-on threshold		$-V_{TON}$		11.3	12.3	V
Phase Control						
Input current	Voltage sync. Pin 7	$\pm I_{syncV}$		0.15	2	mA
	Current sync. Pin 8	$\pm I_{syncI}$	3		30	μA
Voltage limitation	$\pm I_L = 2 \text{ mA}$ Pin 7	$\pm V_{syncV}$	8.0	8.5	9.0	V
Reference Ramp (see Figure 5)						
Charge current	Pin 7	I_ϕ	1		100	μA
Start voltage	Pin 2	$-V_{max}$	1.85	1.95	2.05	V
Temperature coefficient of start voltage	Pin 2	$-TC_R$		-0.003		%/K
R_ϕ - reference voltage	$I_\phi = 10 \mu\text{A}$, Pins 6 to 5	$V_{R\phi}$	0.96	1.02	1.10	V
Temperature coefficient	$I_\phi = 10 \mu\text{A}$, Pin 6 $I_\phi = 1 \mu\text{A}$	$TC_{VR\phi}$		0.03		%/K
		$TC_{VR\phi}$		0.06		%/K
Pulse Output (see Figure 6) (Pin 8)						
Output-pulse current	$V_8 = -1.2$, $R_{GT} = 0 \Omega$	I_0	100	125	150	mA
Output-pulse width	$C_3 = 3.3 \text{ nF}$, $V_S = V_{limit}$	t_p		30		μs
Automatic Retriggering (Pin 8)						
Turn-on threshold voltage		$\pm V_{ION}$	20		60	mV
Repetition rate	$I_7 \geq 150 \mu\text{A}$	t_{pp}	3	5	7.5	t_p
Soft Start (see Figure 8) (Pin 1)						
Starting current	$V_{1-4} = 8 \text{ V}$	I_0	5	10	15	μA
Final current	$V_{1-4} = -2 \text{ V}$	I_0	15	25	40	μA
Discharge current		$-I_0$	0.5			mA
Output current	Pin 3	$-I_0$	0.2		2	mA
Mains Voltage Compensation (see Figure 9)						
Current transfer gain I_7/I_3	Pins 7, Pin 3 Pins 1 and 2 open	G_i	14	17	20	
Reverse current	$V_{(R6)} = V_3 = V_7 = 0$, Pin 3	$\pm I_R$			2	μA
Load-current Detection, $V_7 = 0$ (see Figure 11)						
Transfer gain	I_3/V_1	G	0.28	0.32	0.37	$\mu\text{A/mV}$
Offset current	$V_1 = 0$, $V_3 = -8 \text{ V}$, Pin 3	I_0	0	3	6	μA
Input voltage	Pin 1	$-V_1$	300		400	mV
Input offset voltage	Pin 1	$\pm V_0$			6	mV

Figure 5. Ramp Control

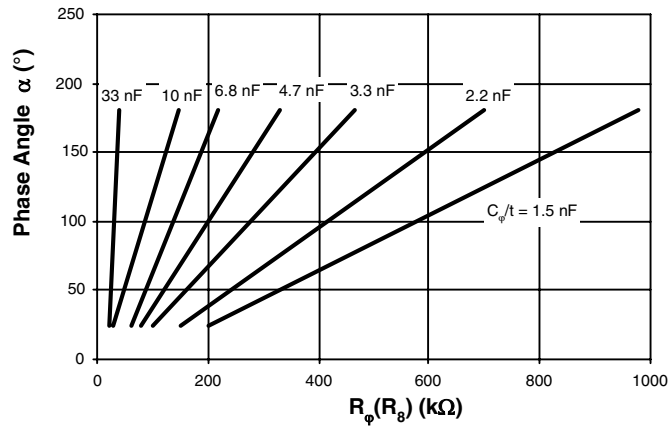


Figure 6. Pulse Output

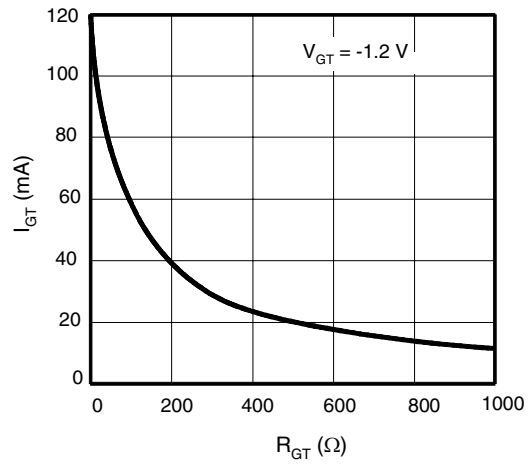


Figure 7. Output Pulse Width

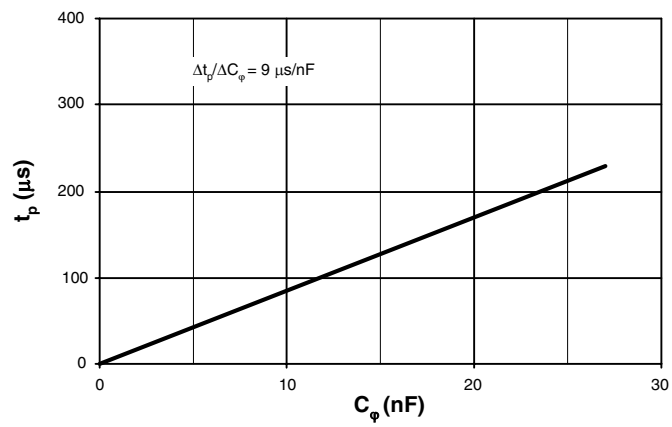


Figure 8. Option Soft Start

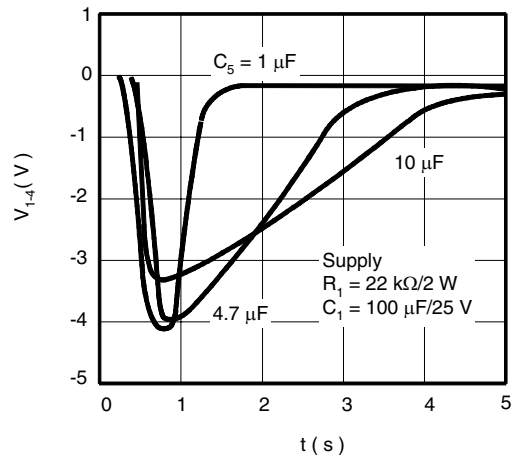


Figure 9. Mains Voltage Compensation

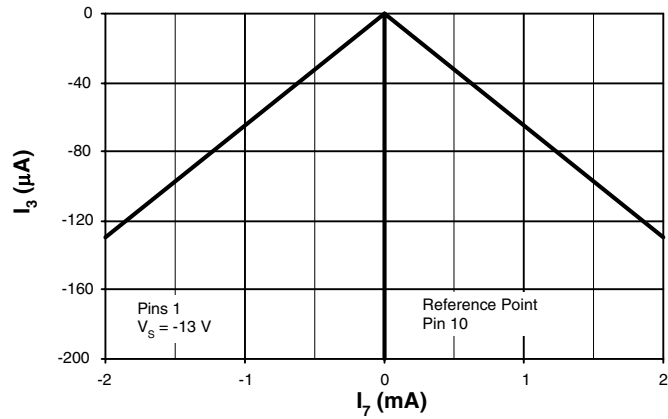


Figure 10. Maximum Resistance of R_1

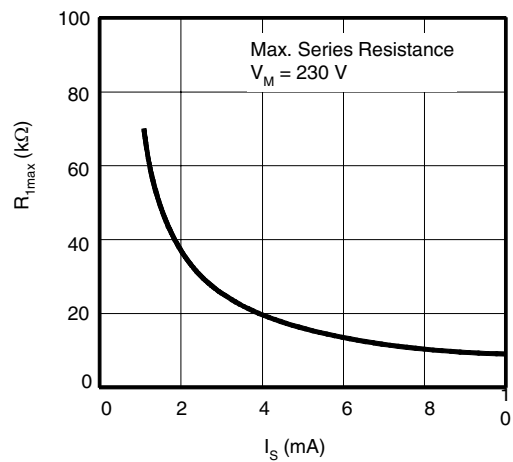


Figure 11. Load-current Detection

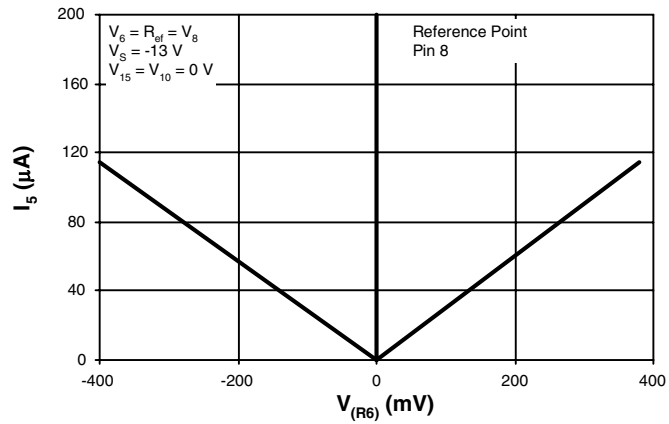


Figure 12. Power Dissipation of R_1

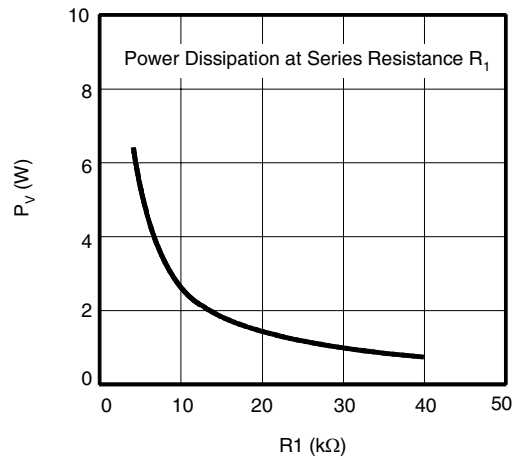
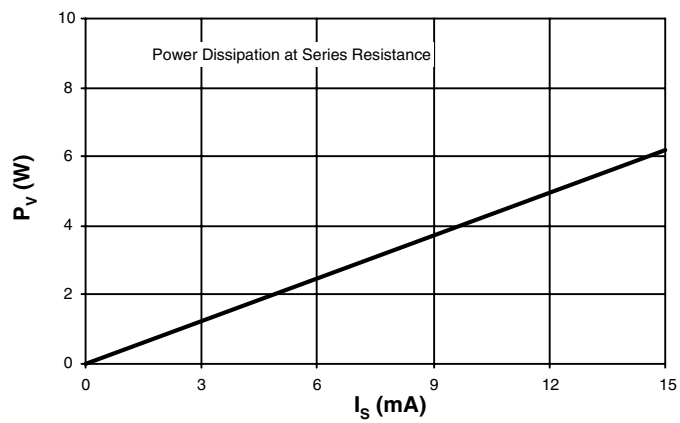


Figure 13. Power Dissipation of R_1 According to Current Consumption



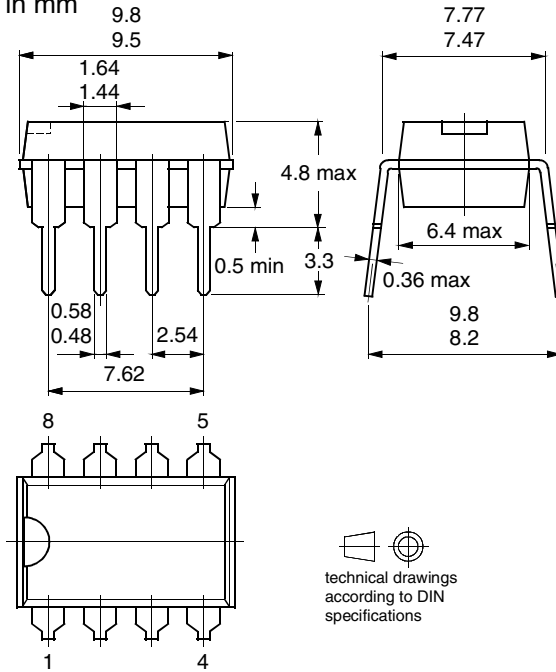
Ordering Information

Extended Type Number	Package	Remarks
U2008B-x	DIP8	Tube
U2008B-xFP	SO8	Tube
U2008B-xFPG3	SO8	Taped and reeled

Package Information

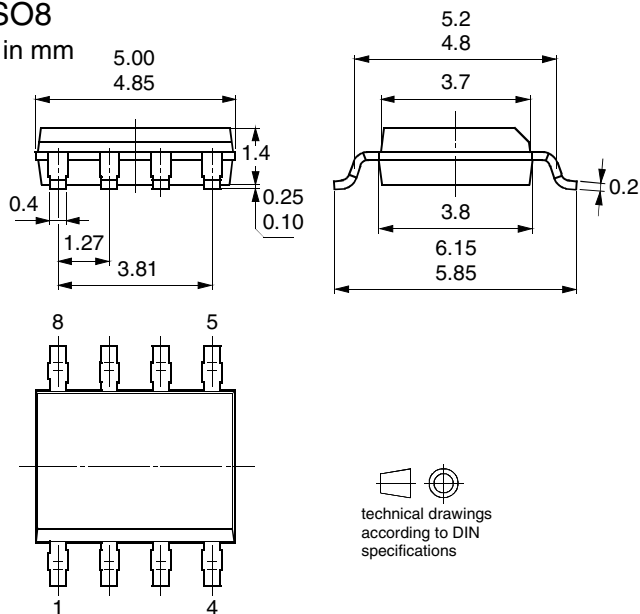
Package DIP8

Dimensions in mm



Package SO8

Dimensions in mm





Atmel Headquarters

Corporate Headquarters

2325 Orchard Parkway
San Jose, CA 95131
TEL 1(408) 441-0311
FAX 1(408) 487-2600

Europe

Atmel Sarl
Route des Arsenaux 41
Case Postale 80
CH-1705 Fribourg
Switzerland
TEL (41) 26-426-5555
FAX (41) 26-426-5500

Asia

Room 1219
Chinachem Golden Plaza
77 Mody Road Tsimhatsui
East Kowloon
Hong Kong
TEL (852) 2721-9778
FAX (852) 2722-1369

Japan

9F, Tonetsu Shinkawa Bldg.
1-24-8 Shinkawa
Chuo-ku, Tokyo 104-0033
Japan
TEL (81) 3-3523-3551
FAX (81) 3-3523-7581

Atmel Operations

Memory

2325 Orchard Parkway
San Jose, CA 95131
TEL 1(408) 441-0311
FAX 1(408) 436-4314

Microcontrollers

2325 Orchard Parkway
San Jose, CA 95131
TEL 1(408) 441-0311
FAX 1(408) 436-4314

La Chantrerie
BP 70602
44306 Nantes Cedex 3, France
TEL (33) 2-40-18-18-18
FAX (33) 2-40-18-19-60

ASIC/ASSP/Smart Cards

Zone Industrielle
13106 Rousset Cedex, France
TEL (33) 4-42-53-60-00
FAX (33) 4-42-53-60-01

1150 East Cheyenne Mtn. Blvd.
Colorado Springs, CO 80906
TEL 1(719) 576-3300
FAX 1(719) 540-1759

Scottish Enterprise Technology Park
Maxwell Building
East Kilbride G75 0QR, Scotland
TEL (44) 1355-803-000
FAX (44) 1355-242-743

RF/Automotive

Theresienstrasse 2
Postfach 3535
74025 Heilbronn, Germany
TEL (49) 71-31-67-0
FAX (49) 71-31-67-2340

1150 East Cheyenne Mtn. Blvd.
Colorado Springs, CO 80906
TEL 1(719) 576-3300
FAX 1(719) 540-1759

Biometrics/Imaging/Hi-Rel MPU/ High Speed Converters/RF Datacom

Avenue de Rochepleine
BP 123
38521 Saint-Egreve Cedex, France
TEL (33) 4-76-58-30-00
FAX (33) 4-76-58-34-80

e-mail

literature@atmel.com

Web Site

<http://www.atmel.com>

© Atmel Corporation 2003.

Atmel Corporation makes no warranty for the use of its products, other than those expressly contained in the Company's standard warranty which is detailed in Atmel's Terms and Conditions located on the Company's web site. The Company assumes no responsibility for any errors which may appear in this document, reserves the right to change devices or specifications detailed herein at any time without notice, and does not make any commitment to update the information contained herein. No licenses to patents or other intellectual property of Atmel are granted by the Company in connection with the sale of Atmel products, expressly or by implication. Atmel's products are not authorized for use as critical components in life support devices or systems.

Atmel® is the registered trademark of Atmel.

Other terms and product names may be the trademarks of others.



Printed on recycled paper.