

**Ultra Low Output Voltage Linear N-FET Controller****AP2160****General Description**

The AP2160 is an ultra low output voltage N-FET linear regulator controller. The output voltage can be adjusted down to 0.5V. A Power-On-Reset (POR) circuit monitors supply voltage to prevent wrong operations. A POK pin indicates the output status. It can control other converters for power sequence. The AP2160 can be enabled by other power systems.

The AP2160 integrates a 0.5V reference voltage with 1% accuracy to provide tight regulation to the output voltage. The regulator also features enable control, open drain power good signal, under-voltage protection and soft start.

The AP2160 is available in 6-pin SOT-23-6 standard package.

**Features**

- 0.5V Reference Voltage with 1% Accuracy
- Adjustable Output Voltage down to 0.5V
- Low ESR Output Capacitor (MLCC and POSCAP) Applicable
- Enable Control for the Output Voltage and Low Shutdown Current
- Under-voltage Short Circuit Protection
- Fast Transient Response
- Power Good Monitoring and Signaling for the Output
- Drive N-Channel MOSFETs

**Applications**

- Notebook PC Computers
- Desktop Computers
- Battery Powered Devices
- Portable Instruments

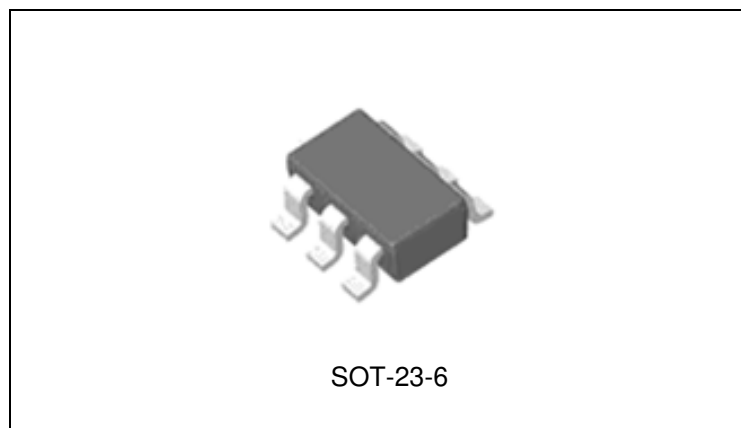

Figure 1. Package Type of AP2160

**Ultra Low Output Voltage Linear N-FET Controller**

**AP2160**

**Pin Configuration**

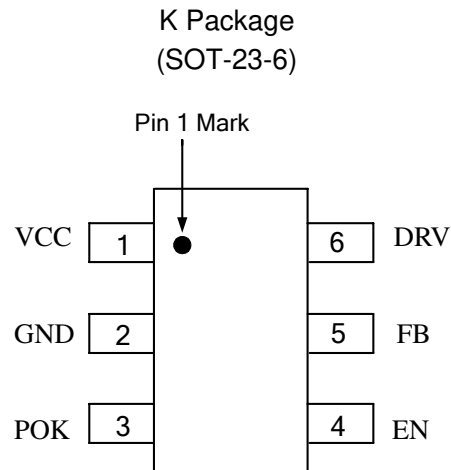

Figure 2. Pin Configuration of AP2160 (Top View)

**Pin Description**

Pin Number	Pin Name	Function
1	VCC	Input voltage
2	GND	Common ground pin
3	POK	Power OK output pin
4	EN	H: Normal operation; L: Shutdown
5	FB	Output voltage feedback pin
6	DRV	Gate drive to N-FET

**Ultra Low Output Voltage Linear N-FET Controller**

**AP2160**

**Functional Block Diagram**

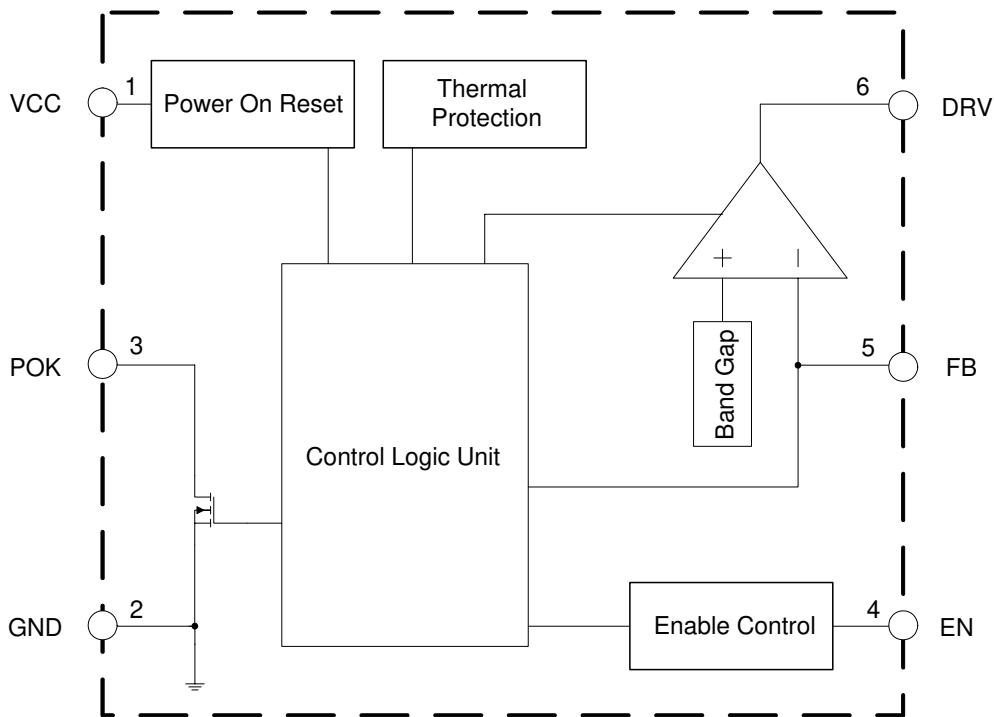
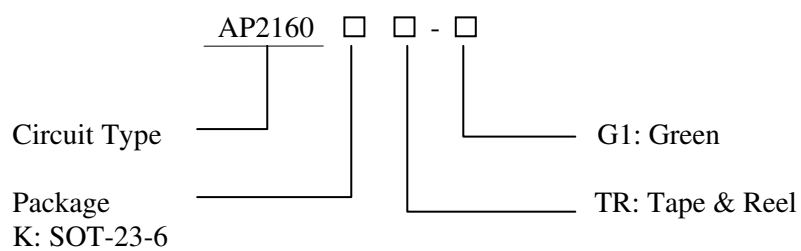

Figure 3. Functional Block Diagram of AP2160

**Ordering Information**



Package	Temperature Range	Part Number	Marking ID	Packing Type
SOT-23-6	-40 to 85°C	AP2160KTR-G1	GJC	Tape & Reel

BCD Semiconductor's Pb-free products, as designated with "G1" suffix in the part number, are RoHS compliant and green.

**Ultra Low Output Voltage Linear N-FET Controller****AP2160****Absolute Maximum Ratings (Note 1)**

Parameter	Symbol	Value	Unit
VCC to GND	V <sub>CC</sub>	-0.3 to 7	V
DRV to GND	V <sub>DRV</sub>	-0.3 to V <sub>CC</sub> +0.3	V
POK to GND	V <sub>POK</sub>	-0.3 to V <sub>CC</sub> +0.3	V
FB to GND	V <sub>FB</sub>	-0.3 to V <sub>CC</sub> +0.3	V
EN to GND	V <sub>EN</sub>	-0.3 to V <sub>CC</sub> +0.3	V
Operating Junction Temperature	T <sub>J</sub>	150	°C
Power Dissipation (25°C)	P <sub>D</sub>	0.4	W
Operating Temperature Range	T <sub>OPR</sub>	-40 to 85	°C
Storage Temperature Range	T <sub>STG</sub>	-65 to 150	°C
Lead Temperature (Soldering, 10 Seconds)	T <sub>LEAD</sub>	260	°C
ESD (Machine Model)		200	V
ESD (Human Body Model)		2000	V

Note 1: Stresses greater than those listed under “Absolute Maximum Ratings” may cause permanent damage to the device. These are stress ratings only, and functional operation of the device at these or any other conditions beyond those indicated under “Recommended Operating Conditions” is not implied. Exposure to “Absolute Maximum Ratings” for extended periods may affect device reliability.

**Recommended Operating Conditions**

Parameter	Symbol	Min	Max	Unit
Supply Voltage (between VCC and GND)	V <sub>CC</sub>	4.5	5.5	V
System Input Voltage (between VIN and GND)	V <sub>IN</sub>	0.5	5.5	V
Ambient Operating Temperature Range	T <sub>A</sub>	-40	85	°C



**Ultra Low Output Voltage Linear N-FET Controller**

**AP2160**

**Electrical Characteristics**

$V_{IN}=1.5V$ ,  $V_{OUT}=1.05V$ ,  $V_{EN}=V_{CC}$ ,  $T_A=25^{\circ}C$ ,  $C_{IN}=4.7\mu F$ ,  $C_{OUT}=22\mu F$ , unless otherwise specified.

Parameter	Symbol	Conditions	Min	Typ	Max	Units
Supply Voltage Range	$V_{CC}$		4.5		5.5	V
Input Voltage UVLO Threshold	$V_{UVLO}$	$V_{FB}=0.48V$ , $V_{CC}$ rising		3.70		V
Input Voltage UVLO Hysteresis	$V_{HYST}$	$V_{FB}=0.48V$ , $V_{CC}$ falling		0.25		V
Supply Current	$I_{CC}$	$V_{EN}=V_{CC}=5V$		0.42	0.6	mA
Shutdown Current	$I_{SD}$	$V_{EN}=0V$	-1		1	$\mu A$
Feedback Voltage	$V_{FB}$	$V_{EN}=V_{CC}=5V$	0.495	0.5	0.505	V
Feedback Pin Input Current	$I_{FB}$	$V_{FB}=0.5V$	-100		100	nA
EN Pin Logic High Threshold Voltage	$V_{EN-H}$	$V_{CC}=5V$ , $V_{EN}$ rising	1.3			V
	$V_{EN-L}$	$V_{CC}=5V$ , $V_{EN}$ falling			0.5	
EN Pin Input Current	$I_{EN}$	$I_{OUT}=0mA$ , $V_{IN}=5V$	-1		1	$\mu A$
Output Voltage UVLO Threshold	$V_{TH(UV)}$	$V_{FB}$ Falling	0.2	0.25	0.3	V
DRV Output Current	$I_{DRV(SS)}$	Sourcing, $V_{FB}=0V$		20		$\mu A$
	$I_{DRV(SRC)}$	Sourcing, $V_{FB}=0.48V$		2.2		mA
	$I_{DRV(SINK)}$	Sinking, $V_{FB}=0.52V$		9.0		
DRV Pin Output Voltage	$V_{DRV}$	$V_{FB}=0.48V$ , $V_{EN}=V_{CC}=5V$	4.9		5.0	V
		$V_{FB}=0.52V$ , $V_{EN}=V_{CC}=5V$	0.8	1.15	1.5	
POK Threshold Voltage for Power not OK	$V_{PNOK}$	$V_{FB}$ falling	84%	88%	91%	$V_{FB}$
POK Low Voltage		POK sinks 1mA		200	250	mV
POK Delay Time	$t_{DELAY}$		0.8	2	10	ms
Thermal Shutdown Temperature	$T_{SD}$			150		$^{\circ}C$
Thermal Shutdown Hysteresis				40		$^{\circ}C$



### Typical Performance Characteristics

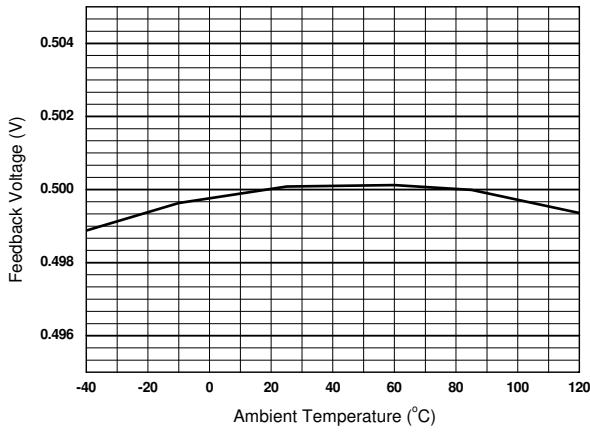

Figure 4. Feedback Voltage vs. Ambient Temperature

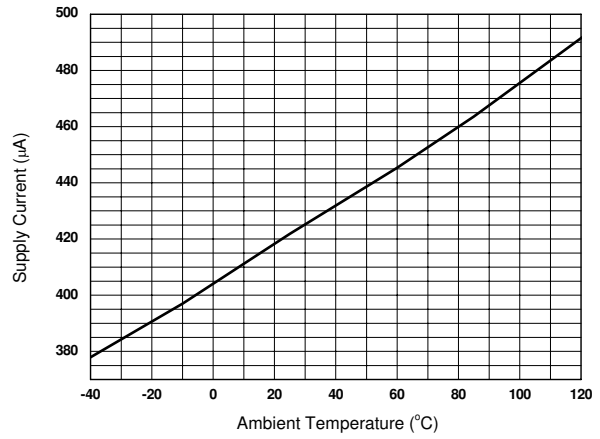

Figure 5. Supply Current vs. Ambient Temperature

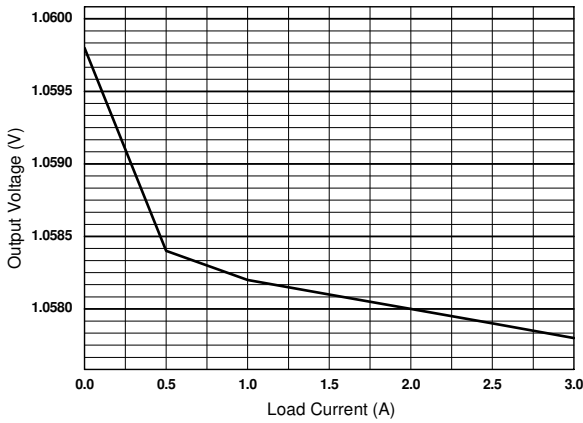

Figure 6. Output Voltage vs. Load Current

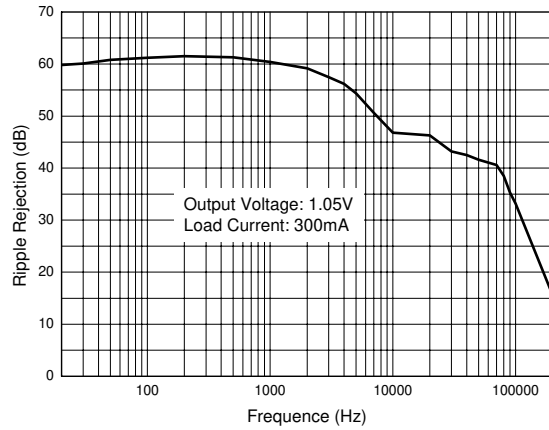

Figure 7. Ripple Rejection vs. Frequency

**Ultra Low Output Voltage Linear N-FET Controller****AP2160****Function Description****1. Power-On-Reset**

A Power-On-Reset (POR) circuit monitors input voltages at VCC pin to prevent wrong logic controls. The POR function initiates a soft-start process after the supply voltages exceed input voltage UVLO threshold during powering on. The POR function also pulls low the POK pin regardless of the output voltage when the VCC voltage falls below the input voltage UVLO threshold minus input voltage UVLO hysteresis.

**2. Output Voltage Regulation**

An error amplifier working with a temperature compensated 0.5V reference and an output NMOS regulates output to the preset voltage. The error amplifier designed with high bandwidth and DC gain

provides very fast transient response and excellent load regulation.

**3. Under-Voltage Protection (UVP)**

AP2160 monitors the voltage on FB pin after soft-start process finishing. Therefore the UVP is disabled during soft-start. When the voltage on FB pin falls below the output voltage UVLO Threshold, the UVP circuit shuts down the output immediately.

**4. Thermal Shutdown**

A thermal shutdown circuit limits the junction temperature of AP2160. When the junction temperature exceeds 150°C, a thermal sensor turns off the output NMOS, allowing the device to cool down. The regulator regulates the output again through initiation of a new soft-start cycle after the junction temperature drops by 40°C.

Typical Application

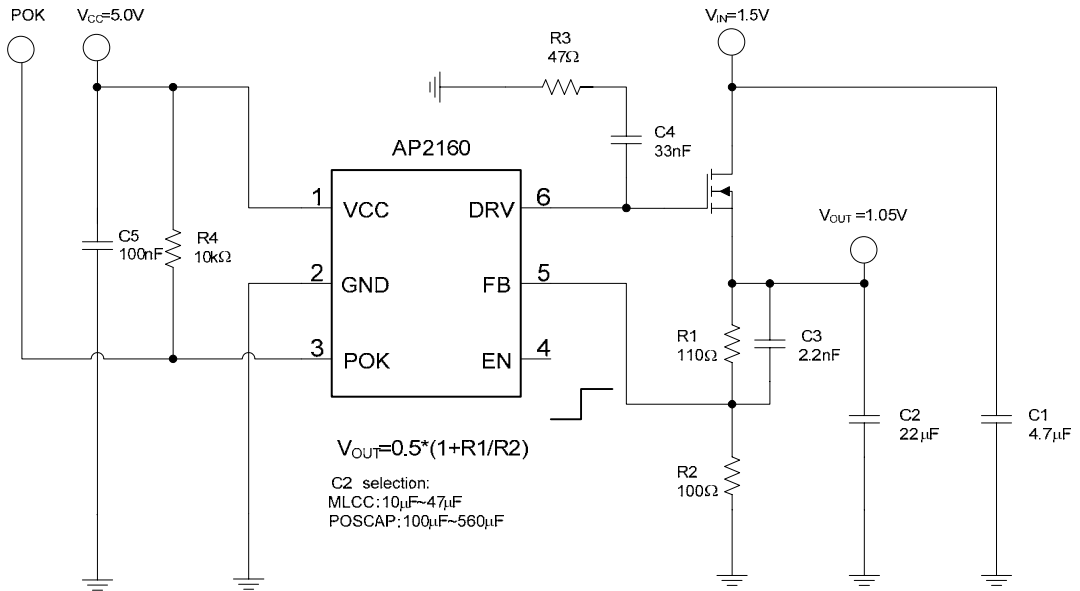
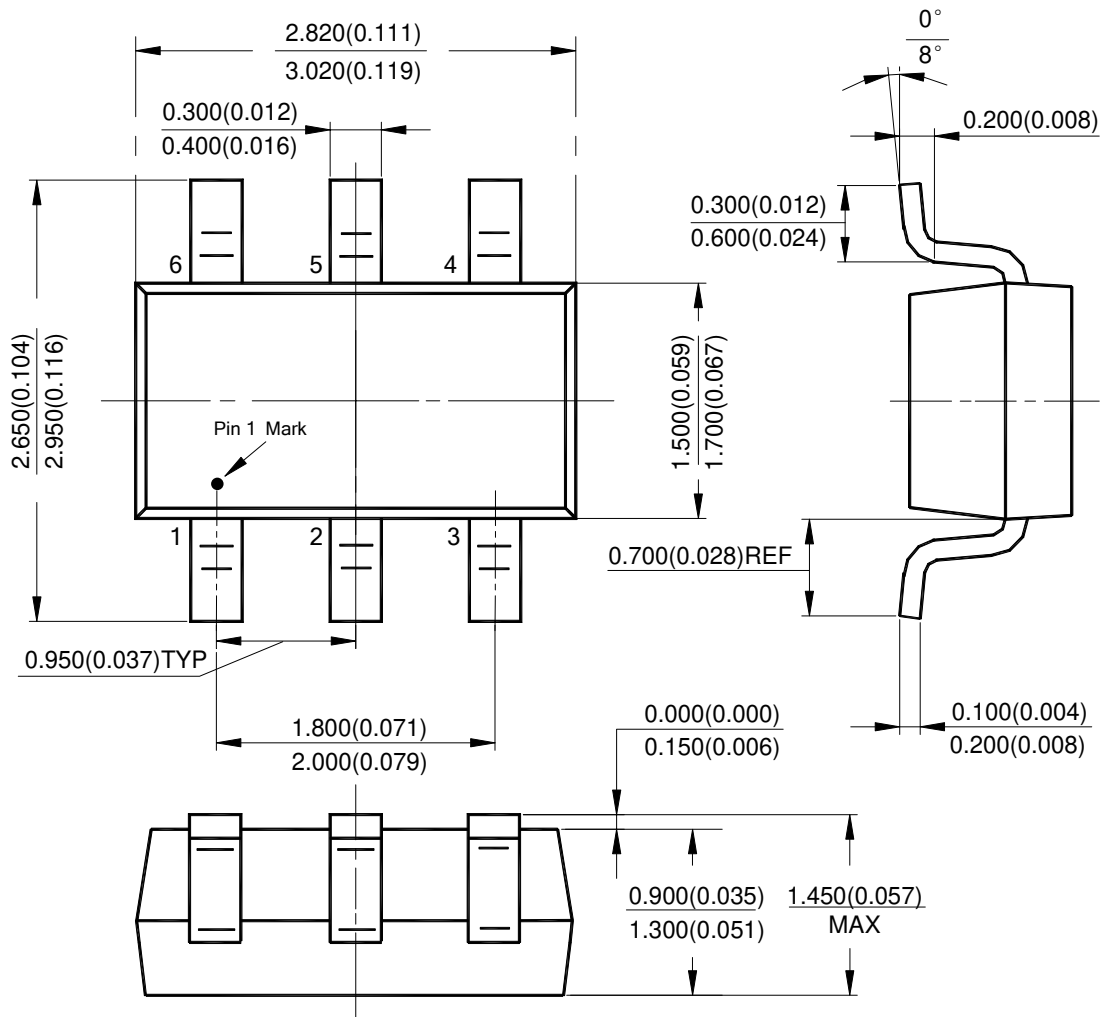

Figure 8. Typical Application Circuit of AP2160



**Ultra Low Output Voltage Linear N-FET Controller**
**AP2160**
**Mechanical Dimensions**
**SOT-23-6**
**Unit: mm(inch)**



## BCD Semiconductor Manufacturing Limited

<http://www.bcdsemi.com>

### IMPORTANT NOTICE

BCD Semiconductor Manufacturing Limited reserves the right to make changes without further notice to any products or specifications herein. BCD Semiconductor Manufacturing Limited does not assume any responsibility for use of any its products for any particular purpose, nor does BCD Semiconductor Manufacturing Limited assume any liability arising out of the application or use of any its products or circuits. BCD Semiconductor Manufacturing Limited does not convey any license under its patent rights or other rights nor the rights of others.

---

#### MAIN SITE

##### - Headquarters

##### BCD Semiconductor Manufacturing Limited

No. 1600, Zi Xing Road, Shanghai ZiZhu Science-based Industrial Park, 200241, China  
Tel: +86-21-24162266, Fax: +86-21-24162277

##### - Wafer Fab

##### Shanghai SIM-BCD Semiconductor Manufacturing Co., Ltd.

800 Yi Shan Road, Shanghai 200233, China  
Tel: +86-21-6485 1491, Fax: +86-21-5450 0008

#### REGIONAL SALES OFFICE

##### Shenzhen Office

##### Shanghai SIM-BCD Semiconductor Manufacturing Co., Ltd., Shenzhen Office

Unit A Room 1203, Skyworth Bldg., Gaoxin Ave. 1.S., Nanshan District, Shenzhen, China  
Tel: +86-755-8826 7951  
Fax: +86-755-8826 7865

##### Taiwan Office

##### BCD Semiconductor (Taiwan) Company Limited

4F, 298-1, Rui Guang Road, Nei-Hu District, Taipei, Taiwan  
Tel: +886-2-2656 2808  
Fax: +886-2-2656 2806

##### USA Office

##### BCD Semiconductor Corp.

30920 Huntwood Ave. Hayward, CA 94544, USA  
Tel : +1-510-324-2988  
Fax: +1-510-324-2788