

## Description

The DIODES™ AL1692K is a high-performance, high-power factor, high-efficiency, and high-current precision Boost, Buck-Boost, and Flyback dimmable LED driver. The device is suited for TRIAC-dimmable LED lamp applications and provides an accurate output current over wide line and load regulation. It achieves higher than 90% efficiency by using a Boost topology to meet the latest high-efficiency requirements. The wide switching frequency operates at boundary conduction mode (BCM) to ease EMI/EMC design and testing.

The AL1692K LED driver integrates a 600V/2A high-voltage MOSFET. It can cover both 120Vac and 230Vac TRIAC-dimmable applications without the need for an external high-voltage MOSFET, which reduces system bill-of-materials (BOM) cost. The AL1692K has built-in thermal fold-back protection to automatically reduce output current. Other protection features also enhance LED lighting system's safety and reliability.

The device's TRIAC dimming curve is compliant with the NEMA SSL6 standard and applies to a wide range of leading and trailing edge dimmers, achieving a deep dim down to 1%.

The AL1692K is available in the SO-7 package.

## Features

- High Efficiency > 90% (Boost Topology)
- Tight Current Sense Tolerance:  $\pm 3\%$
- Low Startup Current: 100 $\mu$ A Typical
- Low Operation Current: 210 $\mu$ A (Switching Frequency at 4kHz)
- Single Winding Inductor
- Wide Range of TRIAC Dimmer Compatibility
- Integration of 600V/2A MOSFET
- NEMA SSL6 Dimming Curve Compliant
- Internal Protections
  - Undervoltage Lockout (UVLO)
  - Leading-Edge Blanking (LEB)
  - Cycle-By-Cycle Overcurrent Protection (OCP)
  - Output Open/Short Protection (OVP/OSP)
  - Thermal Foldback Protection (TFP)
  - Overtemperature Protection (OTP)
- SO-7 Package
- **Totally Lead-Free & Fully RoHS Compliant (Notes 1 & 2)**
- **Halogen and Antimony Free. "Green" Device (Note 3)**
- **For automotive applications requiring specific change control (i.e. parts qualified to AEC-Q100/101/104/200, PPAP capable, and manufactured in IATF 16949 certified facilities), please [contact us](mailto:contact@diodes.com) or your local Diodes representative.**  
<https://www.diodes.com/quality/product-definitions/>

- Notes:
1. No purposely added lead. Fully EU Directive 2002/95/EC (RoHS), 2011/65/EU (RoHS 2) & 2015/863/EU (RoHS 3) compliant.
  2. See <https://www.diodes.com/quality/lead-free/> for more information about Diodes Incorporated's definitions of Halogen- and Antimony-free, "Green" and Lead-free.
  3. Halogen- and Antimony-free "Green" products are defined as those which contain <900ppm bromine, <900ppm chlorine (<1500ppm total Br + Cl) and <1000ppm antimony compounds.

## Pin Assignments

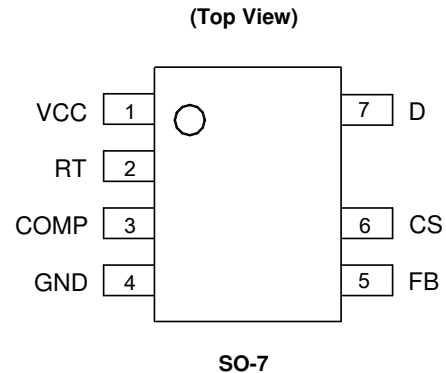

## Applications

- Mains TRIAC-dimmable LED lamps
- Offline LED power supply drivers

**Typical Application Circuits**

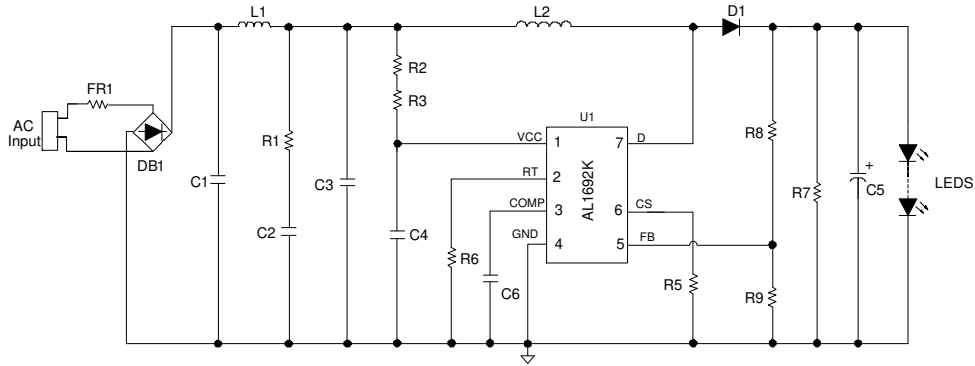

AL1692K Boost Application Circuit

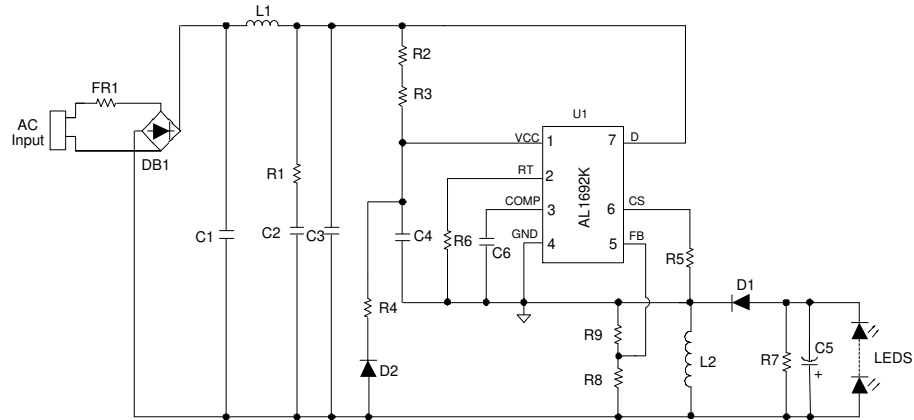

AL1692K Buck-Boost Application Circuit

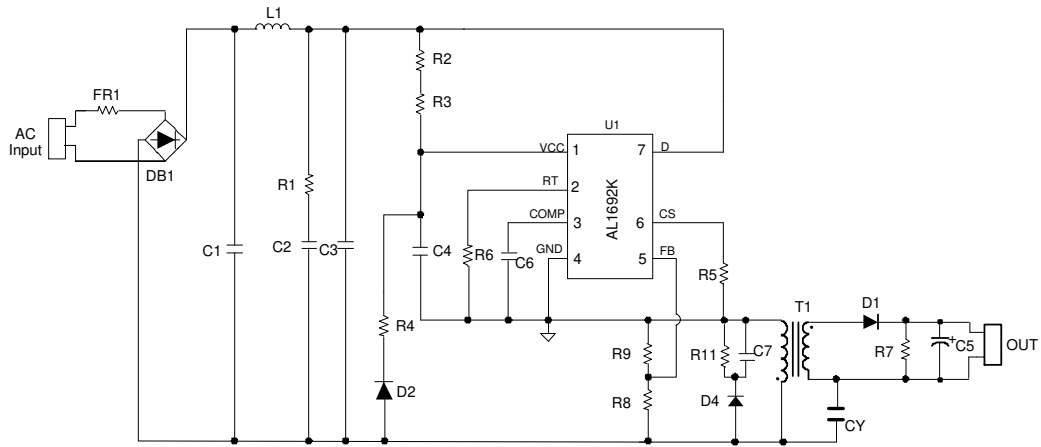

AL1692K Flyback Application Circuit

**Pin Descriptions**

Pin Number	Pin Name	Function
1	VCC	Power Supply Voltage
2	RT	Resistor Set the System's Maximum $t_{ON}$
3	COMP	Compensation for Current Control
4	GND	Ground
5	FB	Feedback for LED Open Protection Voltage
6	CS	Current Sensing
7	D	Drain of the Internal High Voltage MOSFET

**Functional Block Diagram**

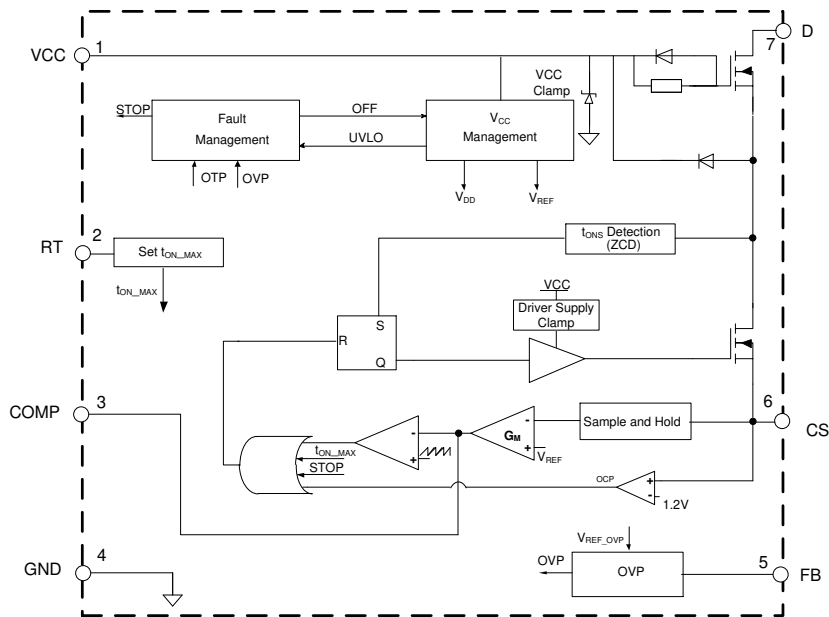

AL1692K Block Diagram

### Absolute Maximum Ratings (@ $T_A = +25^\circ\text{C}$ , unless otherwise specified.) (Note 4)

Symbol	Parameter	Rating	Unit
$V_{CC}$	Power Supply Voltage	18	V
$V_D$	Voltage on Drain Pin	600	V
$I_{DS}$	Continuous Drain Current $T_C = +25^\circ\text{C}$	2	A
$V_{CS}$	Voltage on CS Pin	-0.3 to 7	V
$V_{RT}$	Voltage on RT Pin	-0.3 to 7	V
$V_{FB}$	Voltage on FB Pin	-0.3 to 7	V
$T_J$	Operating Junction Temperature	-40 to +150	$^\circ\text{C}$
$T_{STG}$	Storage Temperature	-65 to +150	$^\circ\text{C}$
$T_{LEAD}$	Lead Temperature (Soldering, 10 seconds)	+260	$^\circ\text{C}$
$P_D$	Power Dissipation ( $T_A = +50^\circ\text{C}$ ) (Note 5)	0.8	W
$\theta_{JA}$	Thermal Resistance (Junction to Ambient) (Note 5)	123	$^\circ\text{C}/\text{W}$
$\theta_{JC}$	Thermal Resistance (Junction to Case) (Note 5)	19	$^\circ\text{C}/\text{W}$
—	ESD (Human Body Model)	2,000	V

- Notes:
- Stresses greater than those listed under “*Absolute Maximum Ratings*” can cause permanent damage to the device. These are stress ratings only, and functional operation of the device at these or any other conditions beyond those indicated under “*Recommended Operating Conditions*” is not implied. Exposure to “*Absolute Maximum Ratings*” for extended periods can affect device reliability. All voltages unless otherwise stated and measured with respect to GND.
  - Device mounted on 1"x1" FR-4 substrate PCB, 2oz copper, with minimum recommended pad layout.

### Recommended Operating Conditions (@ $T_A = +25^\circ\text{C}$ , unless otherwise specified.)

Symbol	Parameter	Min	Max	Unit
$T_A$	Ambient Temperature (Note 6)	-40	+105	$^\circ\text{C}$
$V_{CC}$	Operating $V_{CC}$ Voltage	10	$V_{CC\_CLAMP}(\text{Min})$	V

- Note:
- The device may operate normally at  $+125^\circ\text{C}$  ambient temperature under the condition not trigger temperature protection.

**Electrical Characteristics** (@T<sub>A</sub> = +25°C, unless otherwise specified.)

Symbol	Parameter	Condition	Min	Typ	Max	Unit
<b>UVLO</b>						
V <sub>TH(ST)</sub>	Startup Voltage	—	—	14.5	—	V
V <sub>OPR(MIN)</sub>	Minimal Operating Voltage	After Turn On	—	8.5	—	V
V <sub>CC_CLAMP</sub>	V <sub>CC</sub> Clamp Voltage	I <sub>CC</sub> = 1mA	14	15.5	—	V
<b>Standby Current</b>						
I <sub>ST</sub>	Start-Up Current	V <sub>CC</sub> = V <sub>TH(ST)</sub> -0.5V, Before Start Up	—	100	—	μA
I <sub>CC(OPR)</sub>	Operating Current	Switching Frequency at 4kHz	—	210	—	μA
<b>Source Driver</b>						
R <sub>DS(ON)LV</sub>	Internal Low Voltage MOSFET On-State Resistance (Note 7)	—	—	1	—	Ω
<b>High Voltage and Super-Junction MOSFET</b>						
R <sub>DS(ON)HV</sub>	Drain-Source On-State Resistance	—	—	4	5.5	Ω
V <sub>DS</sub>	Drain-Source Breakdown Voltage	—	600	—	—	V
I <sub>DSS</sub>	Drain-Source Leakage Current	—	—	—	1	μA
<b>RT</b>						
V <sub>RT_REF</sub>	Reference Voltage of RT Pin	—	—	0.5	—	V
<b>Current Sense</b>						
V <sub>CS_CLAMP</sub>	CS Clamp Voltage	—	1.1	1.2	1.3	V
V <sub>REF</sub>	Internal Current Loop Control Reference	—	0.388	0.4	0.412	V
t <sub>ON_MIN</sub>	Minimum t <sub>ON</sub>	—	—	550	—	ns
t <sub>ON_MAX</sub>	Maximum t <sub>ON</sub>	R <sub>T</sub> = 51kΩ, V <sub>COMP</sub> = 4V	—	5.4	—	μs
t <sub>OFF_MIN</sub>	Minimum t <sub>OFF</sub> (Note 7)	—	—	4	—	μs
t <sub>OFF_MAX</sub>	Maximum t <sub>OFF</sub>	—	—	290	—	μs
<b>FB</b>						
V <sub>FB</sub>	Feedback Voltage	—	3.7	3.95	4.18	V
I <sub>FB</sub>	Feedback Pin Input Leakage Current	V <sub>FB</sub> = 2V	—	4	—	μA
<b>Error Amplifier</b>						
G <sub>M</sub>	G <sub>M</sub> Trans-Conductance	—	—	25	—	μA/V
I <sub>SOURCE</sub>	Amplifier Source Current	V <sub>CS</sub> = 0V	—	10	—	μA
I <sub>SINK</sub>	Amplifier Sink Current	V <sub>CS</sub> = 1.5V	—	28	—	μA
<b>Thermal Foldback and Overtemperature Protection (OTP)</b>						
T <sub>FOLD</sub>	Thermal Foldback (Note 7)	—	—	+145	—	°C
—	Thermal Shutdown (Notes 7 & 8)	—	—	+160	—	°C

Notes: 7. These parameters, although guaranteed by design, are not tested in production.  
8. The device will latch off when OTP happens, recovered after power cycle and the device won't operate normally at this temperature.

**Performance Characteristics** (Note 9)

**Start-up Voltage vs. Ambient Temperature**

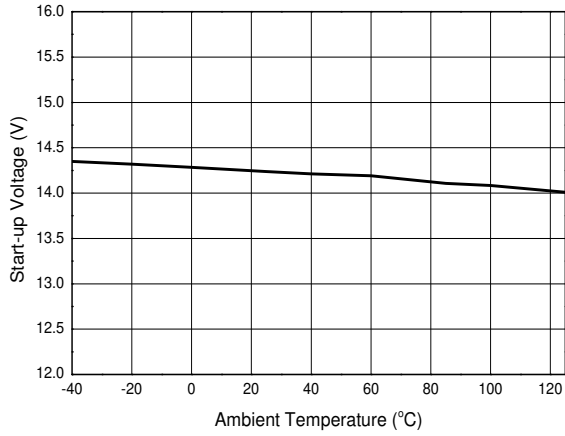

**Minimum Operating Voltage vs. Ambient Temperature**

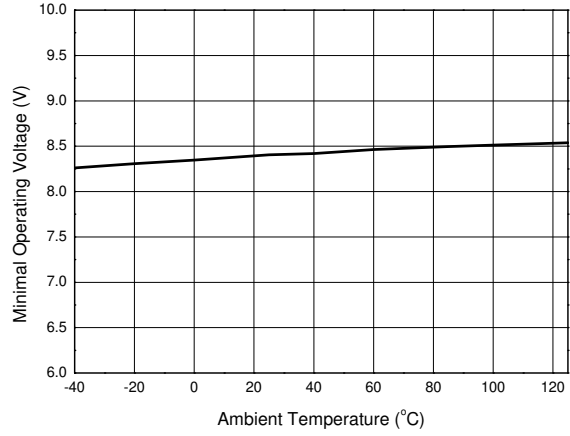

**Start-up Current vs. Ambient Temperature**

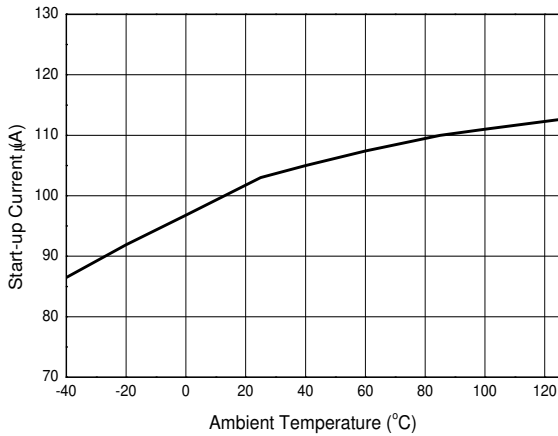

**Operating Current vs. Ambient Temperature**

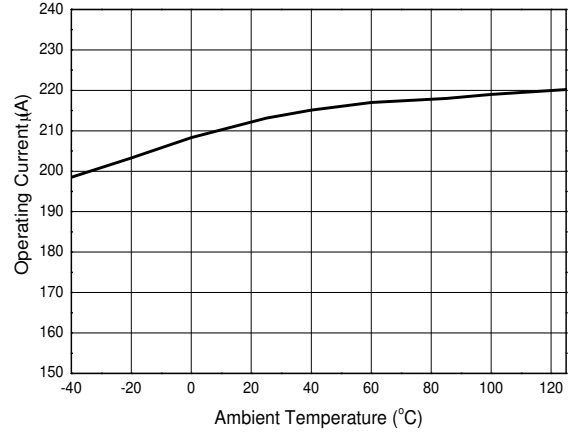

**VCC Clamp Voltage vs. Ambient Temperature**

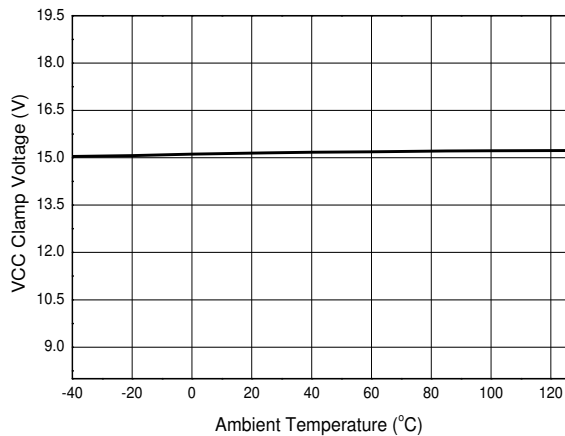

**Feedback Voltage vs. Ambient Temperature**

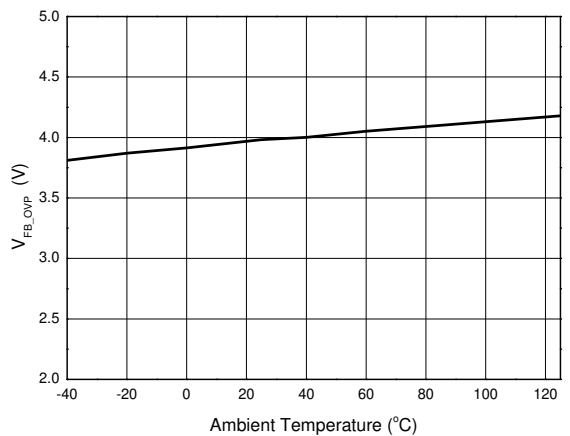

Note: 9. These electrical characteristics are tested under DC condition. The ambient temperature is equal to the junction temperature of the device.

## Functional Description and Application Information

### Operation

The AL1692K is a single-stage, single-winding, high-efficiency, and high-power factor dimmable LED driver for TRIAC-dimmable LED lamp applications. The device integrates a 600V/2A high-voltage MOSFET, and can cover both 120Vac and 230Vac TRIAC dimmable applications while eliminating the need for an external high-voltage MOSFET.

The AL1692K adopts a source-driver technique to decrease system operating current. It uses a novel method to detect the  $t_{OFF}$  time, which removes the need for an auxiliary winding. The AL1692K operates at boundary conduction mode (BCM), which eased EMI design and achieved high efficiency. High power factor (HPF) is achieved by using constant on-time mode. Coupled with a closed loop of constant current control, the AL1692K achieves good line and load regulation.

### Start-Up and Supply Voltage

Before start-up, the  $V_{CC}$  capacitor (C4) is charged by the startup resistors (R2, R3) from the high-voltage mains. When the start-up voltage is reached, the AL1692K starts switching. During normal operation, the  $V_{CC}$  supply is provided by start-up resistors (R2, R3) and the output voltage ( $V_{OUT}$ ) is rectified by one diode (D2). This way, the system can provide  $V_{CC}$  supply at low dimming angle.

The AL1692K has an internal VCC clamp voltage (typical 15.5V), which is limited by one internal active Zener diode.

When VCC voltage drops below the  $V_{OPR(MIN)}$ , the switching is stopped. The device returns to normal operation when the voltage on the VCC pin is between  $V_{OPR(MIN)}$  and VCC clamp voltage.

### Protections

#### Undervoltage Lockout (UVLO)

When the voltage on the VCC pin drops to below  $V_{OPR(MIN)}$ , the IC stops switching. The IC restarts when the voltage on VCC exceeds the startup voltage ( $V_{TH(ST)}$ ).

#### Leading-Edge Blanking (LEB)

To prevent false detection of the peak current of the inductor, a blanking time following switch-on is designed. When the internal switch turns on, a short current spike can occur because of the capacitive discharge of the voltage over the drain and source. It is disregarded during the LEB time ( $t_{ON\_MIN}$ ).

#### Cycle-By-Cycle Overcurrent Protection (OCP)

The AL1692K has a built-in peak current detector. It triggers when the voltage on the CS pin reaches the peak level,  $V_{CS\_CLAMP}$ . The R5 connects to the CS pin to sense the current of the inductor. The maximum peak current ( $I_{PEAK(MAX)}$ ) of the inductor can be calculated as below:

$$I_{PEAK(MAX)} = \frac{V_{CS\_CLAMP}}{R5} \dots\dots\dots (1)$$

The detection circuit is activated after the LEB time. When the detection circuit senses that the CS voltage is higher than 1V, the IC will turn off the switching to limit the output current. It automatically provides protection for the maximum LED current during operation. A propagation delay exists between overcurrent detection and actual source-switch off, so the actual peak current is a little higher than the OCP level set by the R5.

#### Overvoltage Protection and Output-Open Protection (OVP)

The FB pin senses the output voltage, providing an overvoltage protection (OVP) function. When the output is open or a large transient occurs, the output voltage will exceed the rated value (R8, R9). When the voltage exceeds  $V_{FB}$ , overvoltage protection is triggered and the IC will discharge  $V_{CC}$ . When the  $V_{CC}$  is below the UVLO threshold voltage, the IC will restart and the  $V_{CC}$  capacitor is charged again by the start-up resistance. If the overvoltage condition still exists, the system will work in hiccup mode.

#### Output-Short Protection (OSP)

When LED is shorted, the device cannot detect the  $t_{OFF}$  time, and the device controls the system operation at 4kHz low frequency.

**Functional Description and Application Information** (continued)

**Thermal Foldback Protection (TFP)**

The AL1692K has a thermal foldback protection (TFP) function and a self-adaptive control method, which prevent the system from breaking down due to high temperature. The overheating temperature is set at +145°C typical. When the junction temperature of the IC is higher than +145°C, the device will linearly decrease the internal reference voltage to lower output current. As a result of this feature, the device can control the system's output power at high ambient temperatures to control the quantity of heat of the system. This enhances the safety of the system at high temperatures.

Thermal foldback waveform is shown as below:

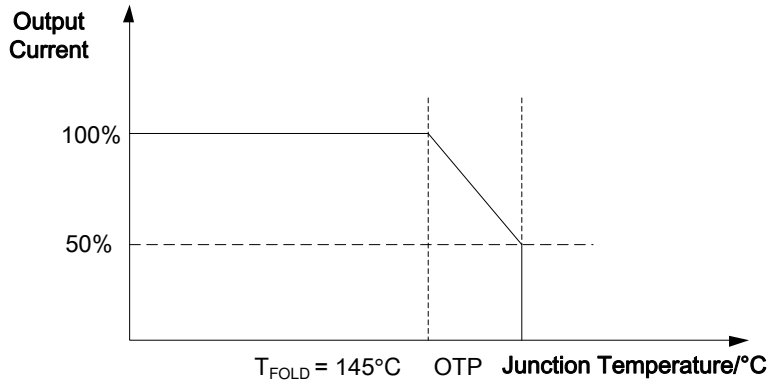

Figure 1. Thermal Foldback Waveform

**Overtemperature Protection (OTP)**

The AL1692K has overtemperature protection (OTP) function. When the junction temperature reaches to +160°C typical, the IC will trigger an overtemperature protection, which causes the device to shut down and latch. Once OTP triggers, the system will resume after the system's AC source supply resets and powers up.

**Design Parameters**

**Setting the Current Sense Resistor R5**

The AL1692K adopts boundary conduction mode. The output current is calculated as below,

$$I_{O\_MEAN} = \frac{1}{\pi} \cdot \int_0^{\pi} \frac{1}{2} \cdot I_{PEAK} \cdot \frac{t_{OFF}}{t_{ON} + t_{OFF} + t_{DELAY}} dt \dots\dots\dots (2) \text{ (Boost, Buck-Boost)}$$

$$I_{O\_MEAN} = \frac{N_P}{N_S} \cdot \frac{1}{\pi} \cdot \int_0^{\pi} \frac{1}{2} \cdot I_{PEAK} \cdot \frac{t_{OFF}}{t_{ON} + t_{OFF} + t_{DELAY}} dt \dots\dots\dots (3) \text{ (Flyback)}$$

Where,

- I<sub>PEAK</sub> is the peak current of the inductance
- t<sub>ON</sub> is the internal MOSFET on-time
- t<sub>OFF</sub> is the freewheel diode (D1) conduction time
- t<sub>DELAY</sub> is typical 0.4µs
- N<sub>P</sub> are the turns of primary winding
- N<sub>S</sub> are the turns of secondary winding

The AL1692K is a closed-loop constant-current control with the relationship between output current and current sense voltage below:

$$V_{REF} = \frac{1}{\pi} \cdot \int_0^{\pi} I_{PEAK} \cdot R5 \cdot \frac{t_{OFF}}{t_{ON} + t_{OFF} + t_{DELAY}} dt \dots\dots\dots (4) \text{ (Boost, Buck-Boost)}$$

$$V_{REF} = \frac{N_P}{N_S} \cdot \frac{1}{\pi} \cdot \int_0^{\pi} I_{PEAK} \cdot R5 \cdot \frac{t_{OFF}}{t_{ON} + t_{OFF} + t_{DELAY}} dt \dots\dots\dots (5) \text{ (Flyback)}$$



**Functional Description and Application Information** (continued)

Where,

- V<sub>REF</sub> is the internal reference, typical 0.4V
- R5 is the current sense resistor

Output current equation as below:

$$I_{O\_MEAN} = \frac{1}{2} \cdot \frac{V_{REF}}{R5} \dots\dots\dots (6) \text{ (Boost, Buck-Boost)}$$

$$I_{O\_MEAN} = \frac{1}{2} \cdot \frac{N_p}{N_s} \cdot \frac{V_{REF}}{R5} \dots\dots\dots (7) \text{ (Flyback)}$$

**Inductance Selection (L2, or Lp of T1)**

The peak current of the inductance can be calculated below:

$$I_{PEAK} = \frac{\pi \cdot V_{REF}}{R5 \cdot \int_0^\pi \sin(\theta) \cdot \frac{\sqrt{2} \cdot V_{IN\_RMS} \cdot \sin(\theta)}{V_o} d\theta} \dots\dots\dots (8) \text{ (Boost)}$$

$$I_{PEAK} = \frac{\pi \cdot V_{REF}}{R5 \cdot \int_0^\pi \sin(\theta) \cdot \frac{\sqrt{2} \cdot V_{IN\_RMS} \cdot \sin(\theta)}{\sqrt{2} \cdot V_{IN\_RMS} \cdot \sin(\theta) + V_o} d\theta} \dots\dots\dots (9) \text{ (Buck-Boost)}$$

$$I_{PEAK} = \frac{\pi \cdot N_s \cdot V_{REF}}{N_p \cdot R5 \cdot \int_0^\pi \sin(\theta) \cdot [1 + \frac{N_p \cdot V_o}{\sqrt{2} \cdot N_s \cdot V_{IN\_RMS} \cdot \sin(\theta)}] d\theta} \dots\dots\dots (10) \text{ (Flyback)}$$

Where,

- V<sub>IN\_RMS</sub> is the input voltage's RMS value
- V<sub>O</sub> is the system output voltage

The AL1692K controls the system operating at boundary conduction mode, which results in an inconstant operating frequency. To set the minimum switching frequency f<sub>MIN</sub> at the crest of the minimum AC input, see the below equations:

$$L2 = \frac{\sqrt{2}V_{IN\_RMS} \cdot (V_o - \sqrt{2}V_{IN\_RMS})}{I_{PEAK} \cdot V_o \cdot f_{MIN}} \dots\dots\dots (11) \text{ (Boost)}$$

$$L2 = \frac{\sqrt{2}V_{IN\_RMS} \cdot V_o}{I_{PEAK} \cdot (\sqrt{2}V_{IN\_RMS} + V_o) \cdot f_{MIN}} \dots\dots\dots (12) \text{ (Buck-Boost)}$$

$$L_p = \frac{\sqrt{2}V_{IN\_RMS} \cdot N_p \cdot V_o}{I_{PEAK} \cdot (N_p \cdot V_o + \sqrt{2}N_s \cdot V_{IN\_RMS}) \cdot f_{MIN}} \dots\dots\dots (13) \text{ (Flyback)}$$

According to the Faraday's Law, the (primary) winding number of the inductance can be calculated by:

$$N_{L2} = \frac{L2 \cdot I_{PEAK}}{A_e \cdot B_m} \dots\dots\dots (14) \text{ (Boost, Buck-Boost)}$$

$$N_p = \frac{L_p \cdot I_{PEAK}}{A_e \cdot B_m} \dots\dots\dots (15) \text{ (Flyback)}$$

Where,

- A<sub>e</sub> is the core effective area
- B<sub>m</sub> is the maximum magnetic flux density

---

## Functional Description and Application Information (continued)

---

### t<sub>ON\_MAX</sub> Setting

In order to get good dimmer compatibilities and dimming depths, the device sets a t<sub>ON\_MAX</sub> by one external resistor R<sub>T</sub> (R6).

The t<sub>ON\_MAX</sub> time has the below equation:

$$t_{ON\_MAX} = \frac{3.3C_{REF}}{\frac{V_{RT\_REF}}{10R_6} + 0.33\mu A} \dots\dots\dots (16) \text{ (Boost, Buck-Boost, Flyback)}$$

Where

V<sub>RT\_REF</sub> is the internal RT pin 0.5V's reference

C<sub>REF</sub> is the internal 1.5pF capacitor

### TRIAC Dimming Control

The AL1692K is a closed-loop control device; the dimming function is realized by t<sub>ON\_MAX</sub> limited when a TRIAC dimmer is connected. When the dimmer is at the largest conduction angle, the device still has adjustability to control the output current constant before COMP voltage is adjusted to the maximum 4V. Thus at the largest conduction angle, the output current for most TRIAC dimmers is nearly the same as conditions without a dimmer. If the conduction angle is decreased, the COMP pin voltage will continue to increase quickly to the maximum level (typical 4V), the device will output t<sub>ON\_MAX</sub> to limit the system's output current. t<sub>ON\_MAX</sub> is set by the RT pin connected to a resistor, so the dimming depth can be adjusted by an RT resistor (R6).

Before the AL1692K enters t<sub>ON\_MAX</sub> mode, it keeps the output current the same as conditions with no dimmers. When entering t<sub>ON\_MAX</sub> mode, the following equation is achieved:

$$I_{PEAK\_DIM} = \frac{\sqrt{2}V_{IN\_RMS} \cdot \sin(\theta) \cdot t_{ON\_MAX}}{L2} \dots\dots\dots (17) \text{ (Boost, Buck-Boost, Flyback)}$$

From the output current equation, one can get the output current when dimming:

$$I_o(\alpha) = \begin{cases} \frac{1}{2} \cdot \frac{V_{REF}}{R5} & \text{if } t_{ON} < t_{ON\_MAX} \\ \frac{1}{\pi} \int_0^\alpha \frac{1}{2} \cdot I_{PEAK\_DIM} \cdot \frac{\sqrt{2}V_{IN\_RMS} \cdot \sin(\theta)}{V_o} d\theta & \text{else} \end{cases} \dots\dots\dots (18) \text{ (Boost)}$$

$$I_o(\alpha) = \begin{cases} \frac{1}{2} \cdot \frac{V_{REF}}{R5} & \text{if } t_{ON} < t_{ON\_MAX} \\ \frac{1}{\pi} \int_0^\alpha \frac{1}{2} \cdot I_{PEAK\_DIM} \cdot \frac{\sqrt{2}V_{IN\_RMS} \cdot \sin(\theta)}{\sqrt{2}V_{IN\_RMS} \cdot \sin(\theta) + V_o} d\theta & \text{else} \end{cases} \dots\dots\dots (19) \text{ (Buck-Boost)}$$

$$I_o(\alpha) = \begin{cases} \frac{1}{2} \cdot \frac{N_p}{N_s} \cdot \frac{V_{REF}}{R5} & \text{if } t_{ON} < t_{ON\_MAX} \\ \frac{N_p}{2\pi} \cdot \int_0^\alpha I_{PEAK\_DIM} \cdot \frac{\sqrt{2}V_{IN\_RMS} \cdot \sin(\theta)}{N_p \cdot V_o + \sqrt{2}N_s \cdot V_{IN\_RMS} \cdot \sin(\theta)} d\theta & \text{else} \end{cases} \dots\dots\dots (20) \text{ (Flyback)}$$

Where,

α is the TRIAC dimmer conduction angle

**Functional Description and Application Information** (continued)

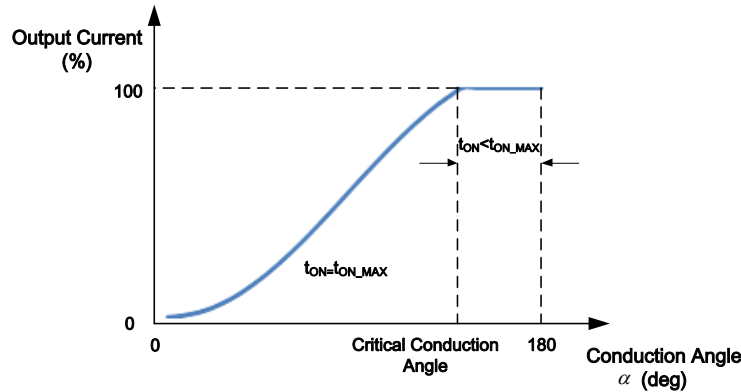

Figure 2. TRIAC Dimming Curve

**Dimmer Compatibility**

**Passive Bleeder Design**

The passive bleeder is designed to supply latching and holding current to eliminate dimmer misfire and flicker.

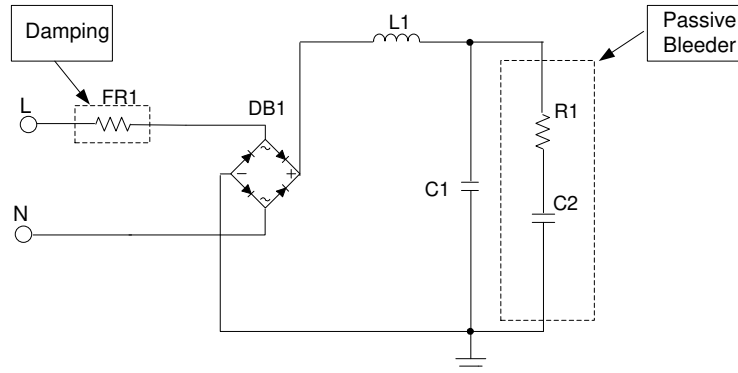

Figure 3. LED Driver Schematic with Passive Bleeder

The passive bleeder includes a capacitor (C2, in hundreds of nF) to provide latching current. A resistor (R1) is necessary to dampen the current spike. Because a large C2 will affect the PF, THD, and efficiency, the value of the capacitor (C2) should be selected accordingly. Generally, 100nF/400V to 330nF/400V is recommended. R1 is used to limit the latching current, If R1 is too large, the latching current is not sufficient enough and the TRIAC dimmer will misfire, causing LED flicker. If R1 is too small, it will result in greater power dissipation. Generally speaking, a 200Ω to 2kΩ resistor is selected for R1.

**Passive Damping Design**

FR-1 is the damper for reducing the spike current caused by quick charging of C2 at firing. In General, FR-1 is selected from 20Ω to 100Ω for low line, such as 120V<sub>AC</sub> applications, and 51Ω to 200Ω for high line, such as 230V<sub>AC</sub> applications.

**Ordering Information**

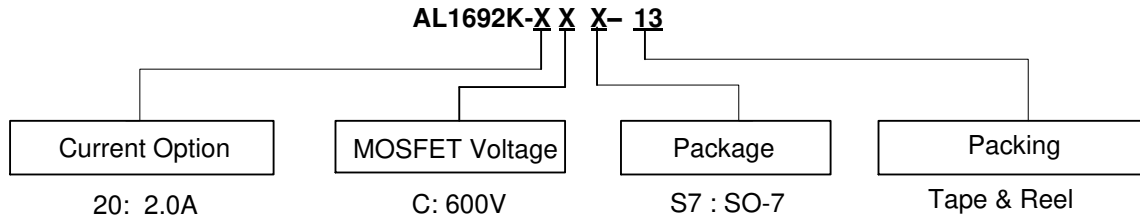

Part Number	Package Code	Package	13" Tape and Reel	
			Quantity	Part Number Suffix
AL1692K-20CS7-13	S7	SO-7	4,000/Tape & Reel	-13

**Marking Information**

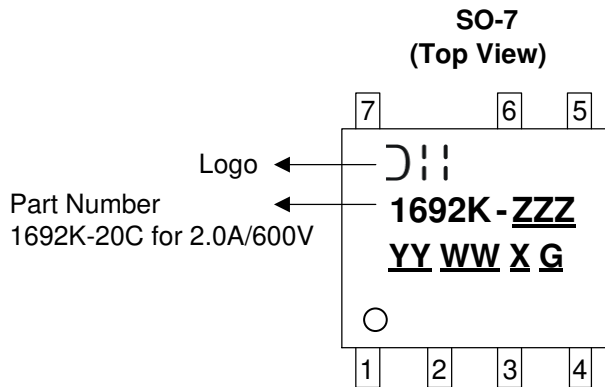

YY : Year : 21,22,23~  
WW : Week : 01 to 52; 52  
 Represents 52 and 53 Week  
X : T to Z for CAT  
 T = Sunday    X = Thursday  
 U = Monday    Y = Friday  
 V = Tuesday    Z = Saturday  
 W = Wednesday  
G: Green Compound

**Package Outline Dimensions**

Please see <http://www.diodes.com/package-outlines.html> for the latest version.

**SO-7**

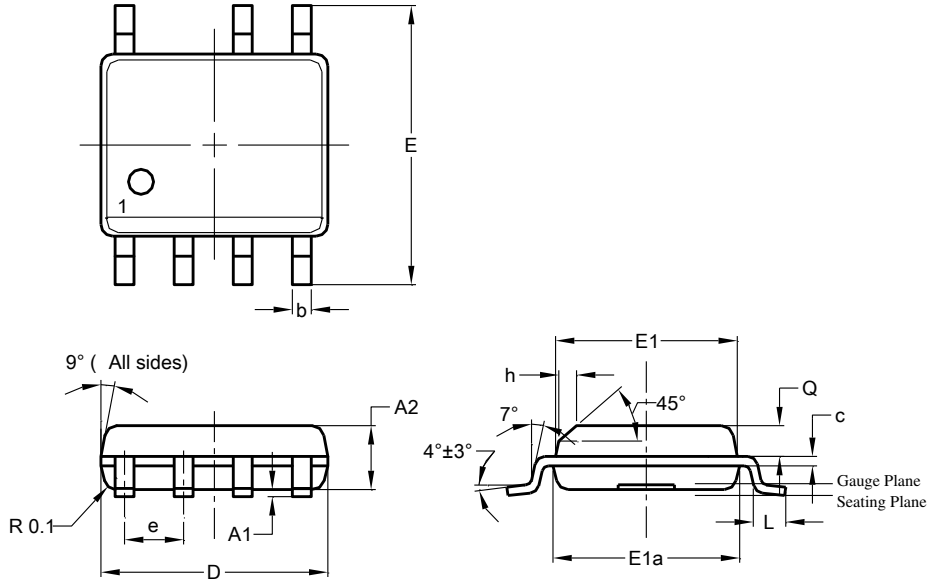

SO-7			
Dim	Min	Max	Typ
A2	1.40	1.50	1.45
A1	0.10	0.20	0.15
b	0.30	0.50	0.40
c	0.15	0.25	0.20
D	4.85	4.95	4.90
E	5.90	6.10	6.00
E1	3.80	3.90	3.85
E1a	3.85	3.95	3.90
e	-	-	1.27
h	-	-	0.35
L	0.62	0.82	0.72
Q	0.60	0.70	0.65
All Dimensions in mm			

**Suggested Pad Layout**

Please see <http://www.diodes.com/package-outlines.html> for the latest version.

**SO-7**

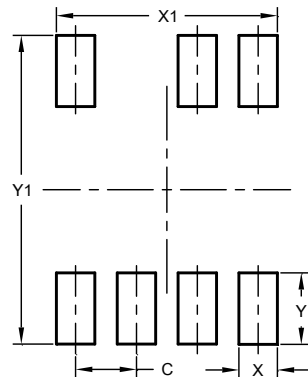

Dimensions	Value (in mm)
C	1.270
X	0.802
X1	4.612
Y	1.505
Y1	6.500

**Mechanical Data**

- Moisture Sensitivity: Level 1 per JESD22-A113
- Terminals: Finish - Matte Tin Plated Leads, Solderable per M2003 JESD22-B102 ③
- Weight: 0.077 grams (Approximate)

**IMPORTANT NOTICE**

1. DIODES INCORPORATED (Diodes) AND ITS SUBSIDIARIES MAKE NO WARRANTY OF ANY KIND, EXPRESS OR IMPLIED, WITH REGARDS TO ANY INFORMATION CONTAINED IN THIS DOCUMENT, INCLUDING, BUT NOT LIMITED TO, THE IMPLIED WARRANTIES OF MERCHANTABILITY, FITNESS FOR A PARTICULAR PURPOSE OR NON-INFRINGEMENT OF THIRD PARTY INTELLECTUAL PROPERTY RIGHTS (AND THEIR EQUIVALENTS UNDER THE LAWS OF ANY JURISDICTION).
2. The Information contained herein is for informational purpose only and is provided only to illustrate the operation of Diodes' products described herein and application examples. Diodes does not assume any liability arising out of the application or use of this document or any product described herein. This document is intended for skilled and technically trained engineering customers and users who design with Diodes' products. Diodes' products may be used to facilitate safety-related applications; however, in all instances customers and users are responsible for (a) selecting the appropriate Diodes products for their applications, (b) evaluating the suitability of Diodes' products for their intended applications, (c) ensuring their applications, which incorporate Diodes' products, comply the applicable legal and regulatory requirements as well as safety and functional-safety related standards, and (d) ensuring they design with appropriate safeguards (including testing, validation, quality control techniques, redundancy, malfunction prevention, and appropriate treatment for aging degradation) to minimize the risks associated with their applications.
3. Diodes assumes no liability for any application-related information, support, assistance or feedback that may be provided by Diodes from time to time. Any customer or user of this document or products described herein will assume all risks and liabilities associated with such use, and will hold Diodes and all companies whose products are represented herein or on Diodes' websites, harmless against all damages and liabilities.
4. Products described herein may be covered by one or more United States, international or foreign patents and pending patent applications. Product names and markings noted herein may also be covered by one or more United States, international or foreign trademarks and trademark applications. Diodes does not convey any license under any of its intellectual property rights or the rights of any third parties (including third parties whose products and services may be described in this document or on Diodes' website) under this document.
5. Diodes' products are provided subject to Diodes' Standard Terms and Conditions of Sale (<https://www.diodes.com/about/company/terms-and-conditions/terms-and-conditions-of-sales/>) or other applicable terms. This document does not alter or expand the applicable warranties provided by Diodes. Diodes does not warrant or accept any liability whatsoever in respect of any products purchased through unauthorized sales channel.
6. Diodes' products and technology may not be used for or incorporated into any products or systems whose manufacture, use or sale is prohibited under any applicable laws and regulations. Should customers or users use Diodes' products in contravention of any applicable laws or regulations, or for any unintended or unauthorized application, customers and users will (a) be solely responsible for any damages, losses or penalties arising in connection therewith or as a result thereof, and (b) indemnify and hold Diodes and its representatives and agents harmless against any and all claims, damages, expenses, and attorney fees arising out of, directly or indirectly, any claim relating to any noncompliance with the applicable laws and regulations, as well as any unintended or unauthorized application.
7. While efforts have been made to ensure the information contained in this document is accurate, complete and current, it may contain technical inaccuracies, omissions and typographical errors. Diodes does not warrant that information contained in this document is error-free and Diodes is under no obligation to update or otherwise correct this information. Notwithstanding the foregoing, Diodes reserves the right to make modifications, enhancements, improvements, corrections or other changes without further notice to this document and any product described herein. This document is written in English but may be translated into multiple languages for reference. Only the English version of this document is the final and determinative format released by Diodes.
8. Any unauthorized copying, modification, distribution, transmission, display or other use of this document (or any portion hereof) is prohibited. Diodes assumes no responsibility for any losses incurred by the customers or users or any third parties arising from any such unauthorized use.
9. This Notice may be periodically updated with the most recent version available at <https://www.diodes.com/about/company/terms-and-conditions/important-notice>

The Diodes logo is a registered trademark of Diodes Incorporated in the United States and other countries.  
DIODES is a trademark of Diodes Incorporated in the United States and other countries.  
All other trademarks are the property of their respective owners.  
© 2022 Diodes Incorporated. All Rights Reserved.

[www.diodes.com](http://www.diodes.com)