

MHSS & MS series

Microminiature slide switches



DISTINCTIVE FEATURES

- Ultra compact size
- Low profile
- Molded-in or epoxy sealed terminals
- Washing not recommended



ENVIRONMENTAL SPECIFICATIONS

- Operating Temperature: MHSS: -45 °C to +85 °C (-49 °F to +185 °F)
MS: -10 °C to +60 °C (14 °F to +140 °F)
- Wave Soldering: MHSS: 260°C (500 °F) max for 5 seconds
MS: 260°C (500 °F) max for 3 seconds



ELECTRICAL SPECIFICATIONS

- Contact rating: 300mA @ 6VDC
- Contact Resistance: 70 milliohms max
- Insulation Resistance: 100 MΩ min. at 500VDC
- Electrical life: 10,000 cycles min.

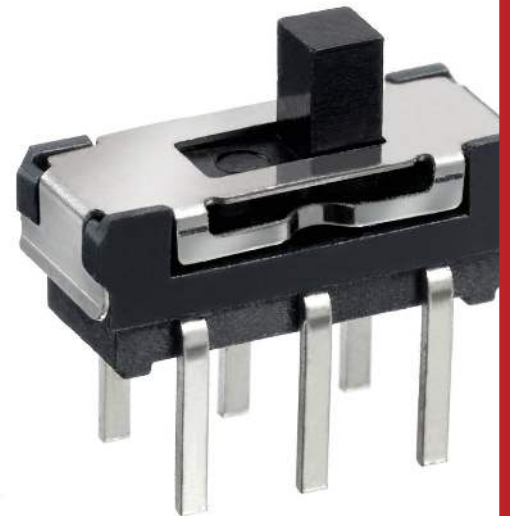

Slide switch series

Microminiature slide switches • MHSS SERIES



SPECIFICATIONS

- Contact rating: 300mA at 6 VDC
- Initial contact resistance: 70 milliohms max.
- Insulation resistance: 100 megohms min. at 100 VDC
- Dielectric strength: 100 volts RMS at sea level
- Electrical life: 10,000 cycles min.
- Operating temperature range: -45°C to +85°C
- Wave Soldering: 260°C max. for 5 seconds
- Washing not recommended



FEATURES

- Excellent tactile feedback (detent action)
- Molded-in terminals minimize flux or solder entry
- Ultra compact case size
- Low Profile



MATERIALS

- Contacts & terminals: Silver plated
- Case: 30% Glass filled nylon, type 6/6, black
- Actuator: Nylon, type 6/6, black

MHSS1104

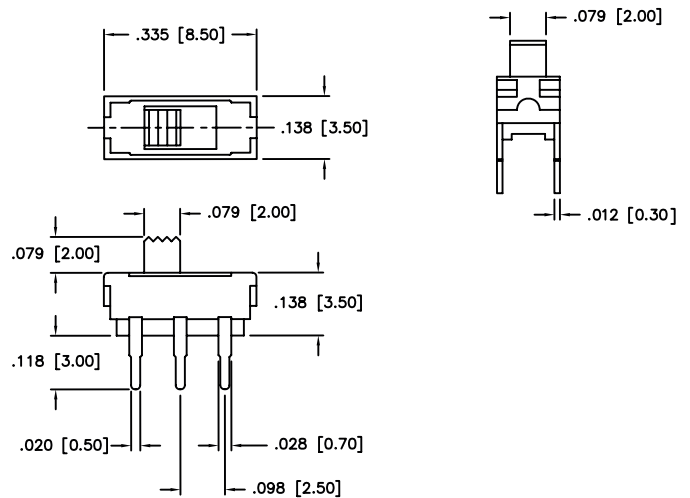
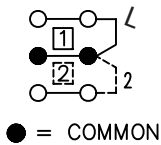

MHSS1105

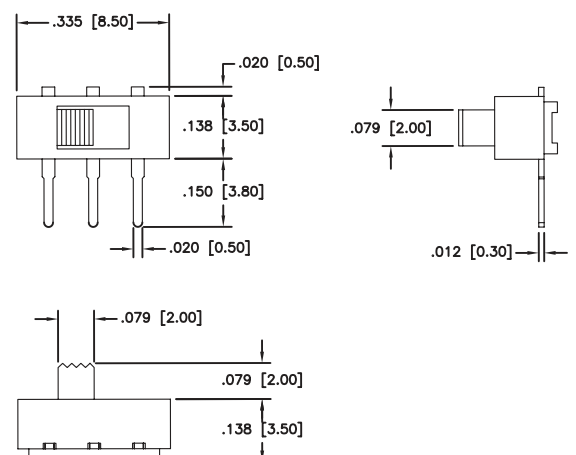
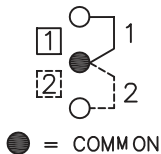

Slide switch series

Microminiature slide switches • MS SERIES



SPECIFICATIONS

- Contact rating: 300mA at 6VDC
- Initial contact resistance: 70 milliohms max.
- Insulation resistance: 100 megohms min. at 500VDC
- Dielectric strength: 500 volts RMS at sea level
- Electrical life: 10,000 cycles min.
- Operating temperature range: -10°C to +60°C
- Wave Soldering: 260°C max. for 3 seconds
- Washing not recommended



FEATURES

- Low profile
- Insert molded terminals
- Stainless steel cover



MATERIALS

- Contacts & terminals: Silver plated
- Cover: Stainless steel
- Actuator: Thermoplastic
- Base: High temperature thermoplastic
- Terminal seal: Insert molded

MS22



● = COMMON

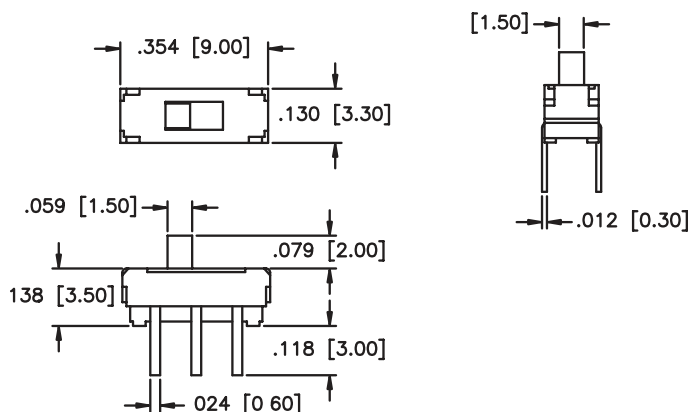

MS22R



● = COMMON

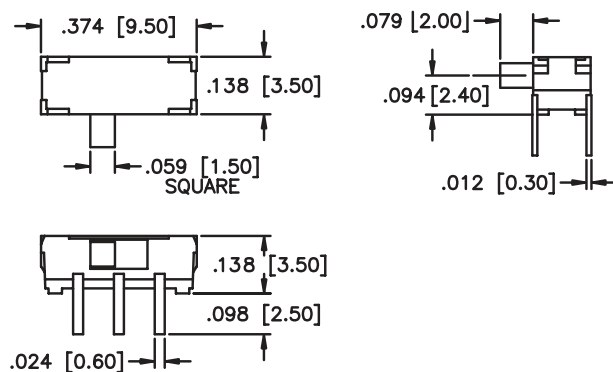

Slide switch series

Microminiature slide switches • MS SERIES

MS42R

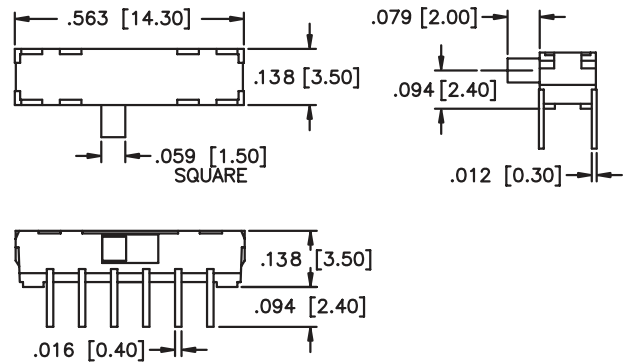
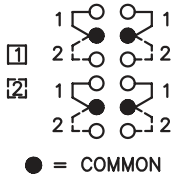

PCB LAYOUT

MHSS1104

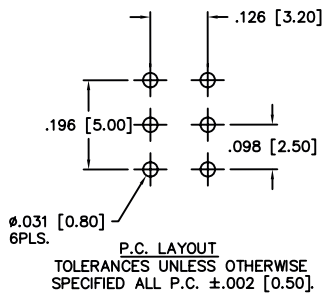

MHSS1105

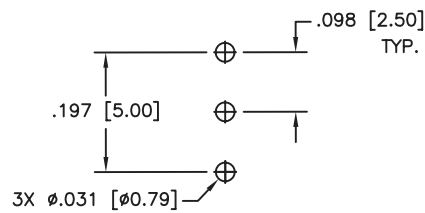

MS22

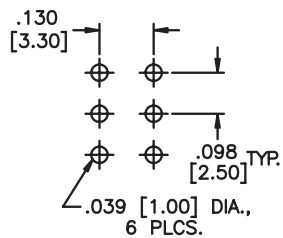

MS22R

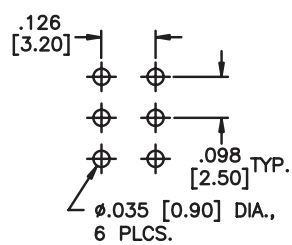

MS42R

