

## 2-Gbps DIFFERENTIAL SWITCH 8-Bit, 1:2 MULTIPLEXER/DEMULTIPLEXER WITH 3-SIDE BAND SIGNALS

Check for Samples: [TS3DV20812](#)

### FEATURES

- Four High-Speed Bidirectional Differential Pair Channel MUX/DEMUX
- Supports up to 2 Gbps Data Rate
- $V_{DD}$  Operating Range 2.5 V or 3.3
  - -0 V to 3.3 V Rail To Rail at 2.5 V
  - -0 V to 5 V Rail To Rail at 3.3V
- $I_{OFF}$  partial Powerdown and Back-Drive Protection.
- 5-V Input Tolerant on Control Pin
- Supports Both AC- and DC-Coupled Signals
- Low Crosstalk: -38 dB at 825 MHz, 2.5 V or 3.3 V
- Insertion Loss: -1.5 dB at 825 MHz, 2.5 V or 3.3 V
- Off Isolation -24.67 dB at 825 MHz
- Low Bit-to-Bit Skew within Pair 5 ps Maximum
- Channel-to-Channel Skew: 30 ps Maximum
- Propagation Delay Times: 250 ps Maximum
- ESD Performance Tested per JESD 22
  - 2000-V Human Body Model (A114-B, Class II)
  - 1000-V Charged-Device Model (C101)

### APPLICATIONS

- HDMI/DVI Video MUX
- Panel LVDS Bus MUX
- LVDS, LVPECL, CML
- Analog Signals VGA
- Gigabit LAN Signal MUX
- Serial Backplane Signal MUX
- Optical Module
- Central Office Telecommunication
- Wireless Base Station
- High-Speed Logic Data I/O MUX

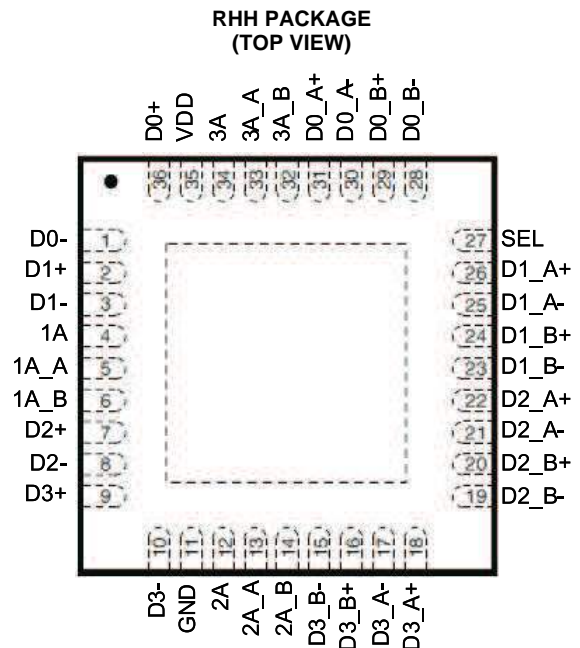

### DESCRIPTION/ORDERING INFORMATION

TS3DV20812 is a High Speed Data Rate up to 2Gbps for Differential Signal Passive bi-directional Multiplexer and De-multiplexer for I/O rails up to 5V Level with Low Crosstalk and Insertion Loss.

TS3DV20812 can be used in either HDMI/DVI sink side or source side with 4-differential pair supporting the high speed and control pins.

The Ioff and back drive protection allowing to connect the external cable and prevent the back flow current when the Vcc is into 0V.

The 3 side band signals can be used in DDC (SDAL, SCL) and CEC Signal MUX.

TS3DS20812 is characterized for operation from -40C to 85C.



Please be aware that an important notice concerning availability, standard warranty, and use in critical applications of Texas Instruments semiconductor products and disclaimers thereto appears at the end of this data sheet.

**Table 1. ORDERING INFORMATION**

T <sub>A</sub>	PACKAGE <sup>(1) (2)</sup>		ORDERABLE PART NUMBER	TOP-SIDE MARKING
-40°C to 85°C	QFN – RHH	Tape and reel	TS3DV20812RHH	TBD

- (1) Package drawings, thermal data, and symbolization are available at [www.ti.com/packaging](http://www.ti.com/packaging).
- (2) For the most current package and ordering information, see the Package Option Addendum at the end of this document, or see the TI website at [www.ti.com](http://www.ti.com).

**LOGIC DIAGRAM**

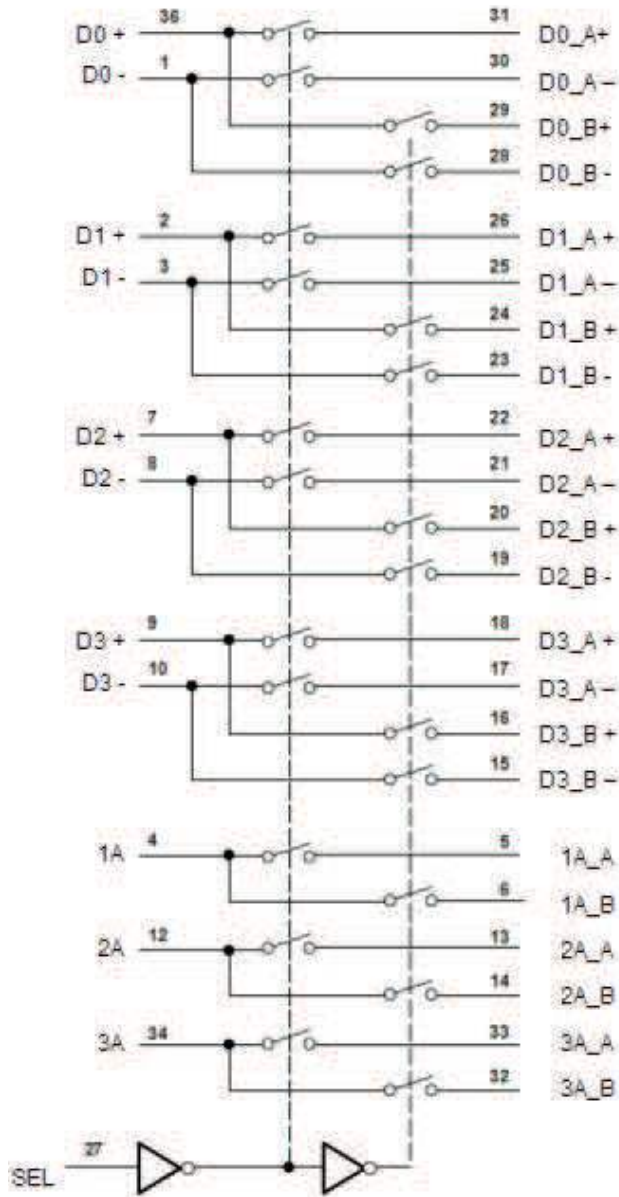

**FUNCTION TABLE**

INPUT SEL	DIFFERENTIAL SIGNAL I/Os	FUNCTIONS	
		A-PORT	B-PORT
L	Dn (±), nA (AUX (±), HPD, CAD/CEC)	DnA (±), nA_A	High-impedance mode
H		High-impedance mode	DnB (±), nA_B

## ABSOLUTE MAXIMUM RATINGS<sup>(1)</sup>

over operating free-air temperature range (unless otherwise noted)

			MIN	MAX	UNIT
V <sub>DD</sub>	Supply voltage range		-0.5	4.6	V
V <sub>IN</sub>	Control input voltage range <sup>(2)(3)</sup>	SEL	-0.5	7	V
		I/O	-0.5	7	V
V <sub>IO</sub>	Switch I/O voltage range (all three I/O ports) <sup>(4)</sup>	D0-D3, Aux, HPD, CAD/CEC	-0.5	V <sub>CC</sub> + 0.5	V
		A port and B port	-0.5	V <sub>CC</sub> + 0.5	V
I <sub>IK</sub>	Control input clamp current	V <sub>IN</sub> < 0		-50	mA
I <sub>I/O</sub> K	I/O port clamp current	V <sub>O</sub> < 0		-50	mA
I <sub>IO</sub>	Continuous output current <sup>(5)</sup>	ON-state switch		±128	mA
			Continuous current through VDD or GND		±100
Θ <sub>JA</sub>	Package thermal impedance <sup>(6)</sup>	RHH package		31.8	°C/W
T <sub>stg</sub>	Storage temperature range		-65	150	°C

- (1) Stresses beyond those listed under "absolute maximum ratings" may cause permanent damage to the device. These are stress ratings only, and functional operation of the device at these or any other conditions beyond those indicated under "recommended operating conditions" is not implied. Exposure to absolute-maximum-rated conditions for extended periods may affect device reliability.
- (2) All voltages are with respect to ground, unless otherwise specified.
- (3) The input and output voltage ratings may be exceeded if the input and output clamp-current ratings are observed.
- (4) V<sub>I</sub> and V<sub>O</sub> are used to denote specific conditions for V<sub>IO</sub>.
- (5) I<sub>I</sub> and I<sub>O</sub> are used to denote specific conditions for I<sub>IO</sub>.
- (6) The package thermal impedance is calculated in accordance with JESD 51-7.

## RECOMMENDED OPERATING CONDITIONS

			MIN	MAX	UNIT
V <sub>DD</sub>	Supply voltage		2.25	3.6	V
V <sub>IH</sub>	High-level control input voltage	SEL	2	5.5	V
V <sub>IL</sub>	Low-level control input voltage	SEL	0	0.8	V
V <sub>I/O</sub>	Input/output voltage	All ports	0	5.5	V
V <sub>ANALOG</sub>	Analog signal range	Differential signal range	0	V <sub>DD</sub>	V
V <sub>I</sub>	Input tolerant	SEL	0	5.5	V
T <sub>A</sub>	Operating free-air temperature		-40	85	°C

## ELECTRICAL CHARACTERISTICS

for high-frequency switching over recommended operating free-air temperature range  $V_{DD} = 3.3 \text{ V} \pm 0.3 \text{ V}$  (unless otherwise noted)

PARAMETER		TEST CONDITIONS <sup>(1)</sup>		MIN	TYP <sup>(2)</sup>	MAX	UNIT
$V_{IK}$	SEL	$V_{DD} = 3.6 \text{ V}$ ,	$I_{IN} = -18 \text{ mA}$		-0.7	-1.2	V
$I_{IH}$	SEL	$V_{DD} = 3.6 \text{ V}$ ,	$V_{IN} = V_{DD}$			$\pm 1$	$\mu\text{A}$
$I_{IL}$	SEL	$V_{DD} = 3.6 \text{ V}$ ,	$V_{IN} = \text{GND}$			$\pm 1$	$\mu\text{A}$
$I_{OFF}$		$V_{DD} = 06 \text{ V}$ ,	$V_O = 0 \text{ to } 3.6 \text{ V}$ , $V_I = 0$ , $V_{IN} = 0$			1	$\mu\text{A}$
$I_{CC}$		$V_{DD} = 3.6 \text{ V}$ ,	$I_{IO} = 0$		250	500	$\mu\text{A}$
$C_{IN}$	SEL	$f = 10 \text{ MHz}$ ,	$V_{IN} = 0$		2	2.5	pF
$C_{OFF}$	3-Port	$f = 10 \text{ MHz}$ ,	$V_{IN} = 0$ , Output is Open, Switch is OFF		2.5	4	pF
$C_{ON}$	3-Port	$f = 10 \text{ MHz}$ ,	$V_{IN} = 0$ , Output is Open, Switch is ON		8		pF
$r_{ON}$		$V_{DD} = 3.6 \text{ V}$	$1.5 \text{ V} \leq V_I \leq V_{DD}$ , $I_O = -40 \text{ mA}$		4	6	$\Omega$
$r_{ON(\text{flat})}$ <sup>(3)</sup>		$V_{DD} = 3.6 \text{ V}$	$1.5 \text{ V} \leq V_I \leq V_{DD}$ , $I_O = -40 \text{ mA}$		0.5		$\Omega$
$\Delta r_{ON}$ <sup>(4)</sup>		$V_{DD} = 3.6 \text{ V}$	$1.5 \text{ V} \leq V_I \leq V_{DD}$ , $I_O = -40 \text{ mA}$		0.4	1	$\Omega$

- (1)  $V_I$ ,  $V_O$ ,  $I_I$ , and  $I_O$  refer to I/O pins,  $V_{IN}$  refers to the control inputs.  
(2) All typical values are at  $V_{DD} = 3.3 \text{ V}$  (unless otherwise noted),  $T_A = 25^\circ$ .  
(3)  $r_{ON(\text{flat})}$  is the difference of  $r_{ON}$  in a given channel at specified voltages.  
(4)  $\Delta r_{ON}$  is the difference of  $r_{ON}$  from center (D0 to Dn) ports to any other port.

## ELECTRICAL CHARACTERISTICS

for high-frequency switching over recommended operating free-air temperature range  $V_{DD} = 2.5 \text{ V} \pm 0.25 \text{ V}$  (unless otherwise noted)

PARAMETER		TEST CONDITIONS <sup>(1)</sup>		MIN	TYP <sup>(2)</sup>	MAX	UNIT
$V_{IK}$	SEL	$V_{DD} = 2.5 \text{ V}$ ,	$I_{IN} = -18 \text{ mA}$		-0.7	-1.2	V
$I_{IH}$	SEL	$V_{DD} = 2.5 \text{ V}$ ,	$V_{IN} = V_{DD}$			$\pm 1$	$\mu\text{A}$
$I_{IL}$	SEL	$V_{DD} = 2.5 \text{ V}$ ,	$V_{IN} = \text{GND}$			$\pm 1$	$\mu\text{A}$
$I_{OFF}$		$V_{DD} = 06 \text{ V}$ ,	$V_O = 0 \text{ to } 2.5 \text{ V}$ , $V_I = 0$ , $V_{IN} = 0$			1	$\mu\text{A}$
$I_{CC}$		$V_{DD} = 2.5 \text{ V}$ ,	$I_{IO} = 0$		250	500	$\mu\text{A}$
$C_{IN}$	SEL	$f = 10 \text{ MHz}$ ,	$V_{IN} = 0$		2	2.5	pF
$C_{OFF}$	3-Port	$f = 10 \text{ MHz}$ ,	$V_{IN} = 0$ , Output is Open, Switch is OFF		2.5	4	pF
$C_{ON}$	3-Port	$f = 10 \text{ MHz}$ ,	$V_{IN} = 0$ , Output is Open, Switch is ON		8		pF
$r_{ON}$		$V_{DD} = 2.5 \text{ V}$	$1.5 \text{ V} \leq V_I \leq V_{DD}$ , $I_O = -40 \text{ mA}$		4	6	$\Omega$
$r_{ON(\text{flat})}$ <sup>(3)</sup>		$V_{DD} = 2.5 \text{ V}$	$V_I = 1.5 \text{ V}$ and $V_{DD}$ , $I_O = -40 \text{ mA}$		0.5		$\Omega$
$\Delta r_{ON}$ <sup>(4)</sup>		$V_{DD} = 2.5 \text{ V}$	$1.5 \text{ V} \leq V_I \leq V_{DD}$ , $I_O = -40 \text{ mA}$		0.4	1	$\Omega$

- (1)  $V_I$ ,  $V_O$ ,  $I_I$ , and  $I_O$  refer to I/O pins,  $V_{IN}$  refers to the control inputs.  
(2) All typical values are at  $V_{DD} = 2.5 \text{ V}$  (unless otherwise noted),  $T_A = 25^\circ$ .  
(3)  $r_{ON(\text{flat})}$  is the difference of  $r_{ON}$  in a given channel at specified voltages.  
(4)  $\Delta r_{ON}$  is the difference of  $r_{ON}$  from center (D0 to Dn) ports to any other port.

## SWITCHING CHARACTERISTICS

over recommended operating free-air temperature range,  $V_{DD} = 3.3\text{ V} \pm 0.3\text{ V}$ ,  $R_L = 200\ \Omega$ ,  $C_L = 10\text{ pF}$  (unless otherwise noted) (see [Figure 9](#) and [Figure 10](#))

PARAMETER	FROM (INPUT)	TO (OUTPUT)	MIN	TYP <sup>(1)</sup>	MAX	UNIT
$t_{pd}^{(2)}$	Dn	D <sub>A</sub> or D <sub>B</sub>		149		ps
$t_{pZH}$ , $t_{pZL}$	SEL	D <sub>A</sub> or D <sub>B</sub>	0.5		15	ns
$t_{pHZ}$ , $t_{pLZ}$	SEL	D <sub>A</sub> or D <sub>B</sub>	0.9		12	ns
SEL to switch turn on time		D <sub>A</sub> or D <sub>B</sub>		9	14	ns
SEL to switch turn off time		D <sub>A</sub> or D <sub>B</sub>		5	11	ns
$t_{sk(o)}^{(3)}$	Dn (+)(-), DA(+)(-), DB(+)(-)			22	28	ps
$t_{sk(o)}$	Dn (all), DnA(all), DnB(All)			19	25	ps
$t_{sk(p)}^{(4)}$				22	31	ps

(1) All typical values are at  $V_{DD} = 2.5\text{ V}$  (unless otherwise noted),  $T_A = 25^\circ$ .

(2) The propagation delay is the calculated RC time constant of the typical ON-State resistance of the switch and the specified load capacitance when driven by an ideal voltage source (zero output impedance).

(3) Output skew between center port to any other port.

(4) Skew between opposite transitions of the same output in a given device  $|t_{pHL} - t_{pLH}|$

## SWITCHING CHARACTERISTICS

over recommended operating free-air temperature range,  $V_{DD} = 2.5\text{ V} \pm 0.25\text{ V}$ ,  $R_L = 200\ \Omega$ ,  $C_L = 10\text{ pF}$  (unless otherwise noted) (see [Figure 9](#) and [Figure 10](#))

PARAMETER	FROM (INPUT)	TO (OUTPUT)	MIN	TYP <sup>(1)</sup>	MAX	UNIT
$t_{pd}^{(2)}$	Dn	D <sub>A</sub> or D <sub>B</sub>		149		ps
$t_{pZH}$ , $t_{pZL}$	SEL	D <sub>A</sub> or D <sub>B</sub>	0.5		14	ns
$t_{pHZ}$ , $t_{pLZ}$	SEL	D <sub>A</sub> or D <sub>B</sub>	0.9		15	ns
SEL to switch turn on time		D <sub>A</sub> or D <sub>B</sub>		9	17	ns
SEL to switch turn off time	D <sub>A</sub> or D <sub>B</sub>	D <sub>A</sub> or D <sub>B</sub>		5	18	ns
$t_{sk(o)}^{(3)}$	Dn (+)(-), DA(+)(-), DB(+)(-)			22	31	ps
$t_{sk(o)}$	Dn (all), DnA(all), DnB(All)			19	23	ps
$t_{sk(p)}^{(4)}$				22	33	ps

(1) All typical values are at  $V_{DD} = 2.5\text{ V}$  (unless otherwise noted),  $T_A = 25^\circ$ .

(2) The propagation delay is the calculated RC time constant of the typical ON-State resistance of the switch and the specified load capacitance when driven by an ideal voltage source (zero output impedance).

(3) Output skew between center port to any other port.

(4) Skew between opposite transitions of the same output in a given device  $|t_{pHL} - t_{pLH}|$

## DYNAMIC CHARACTERISTICS

over recommended operating free-air temperature range,  $V_{DD} = 3.3 \text{ V} \pm 0.3 \text{ V}$ ,  $R_L = 50 \ \Omega$ ,  $C_L = 10 \text{ pF}$  (unless otherwise noted)

PARAMETER		TEST CONDITIONS	TYP	UNIT
$X_{TALK}$	Differential crosstalk	825 MHz, 1.65Gbps, $R_L = 50 \ \Omega$ , $C_L = 10 \text{ pF}$ , see <a href="#">Figure 11</a>	-34.67	dB
$O_{IRR}$	Differential OFF isolation	825 MHz, 1.65Gbps, $R_L = 50 \ \Omega$ , $C_L = 10 \text{ pF}$ , see <a href="#">Figure 12</a>	-19.09	dB
$I_{LOSS}$	Differential insertion loss	825 MHz, 1.65Gbps, $R_L = 50 \ \Omega$ , $C_L = 10 \text{ pF}$ , see <a href="#">Figure 13</a>	-2.84	dB
$I_{RETURN}$	Differential return loss	825 MHz, 1.65Gbps, $R_L = 50 \ \Omega$ , $C_L = 10 \text{ pF}$ , see <a href="#">Figure 13</a>	-9.43	dB
DR	Data rate		2.20	Gbps
BW	Differential bandwidth		1.10	Ghz

## DYNAMIC CHARACTERISTICS

over recommended operating free-air temperature range,  $V_{DD} = 2.5 \text{ V} \pm 0.25 \text{ V}$ ,  $R_L = 50 \ \Omega$ ,  $C_L = 10 \text{ pF}$  (unless otherwise noted)

PARAMETER		TEST CONDITIONS	TYP	UNIT
$X_{TALK}$	Differential crosstalk	825 MHz, 1.65Gbps, $R_L = 50 \ \Omega$ , $C_L = 10 \text{ pF}$ , see <a href="#">Figure 7</a>	-34.94	dB
$O_{IRR}$	Differential OFF isolation	825 MHz, 1.65Gbps, $R_L = 50 \ \Omega$ , $C_L = 10 \text{ pF}$ , see <a href="#">Figure 8</a>	-18.39	dB
$I_{LOSS}$	Differential insertion loss	825 MHz, 1.65Gbps, $R_L = 50 \ \Omega$ , $C_L = 10 \text{ pF}$ , see <a href="#">Figure 9</a>	-3.07	dB
$I_{RETURN}$	Differential return loss	825 MHz, 1.65Gbps, $R_L = 50 \ \Omega$ , $C_L = 10 \text{ pF}$ , see <a href="#">Figure 9</a>	-9.56	dB
DR	Data rate		2.20	Gbps
BW	Differential bandwidth		1.10	Ghz

TYPICAL PERFORMANCE

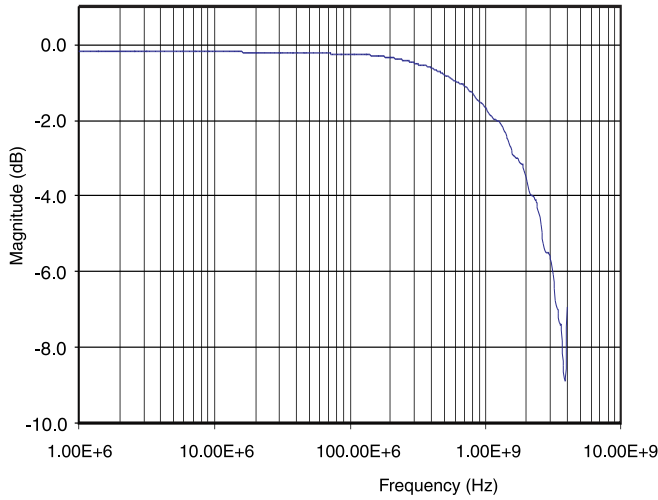

Figure 1. Differential Gain vs Frequency

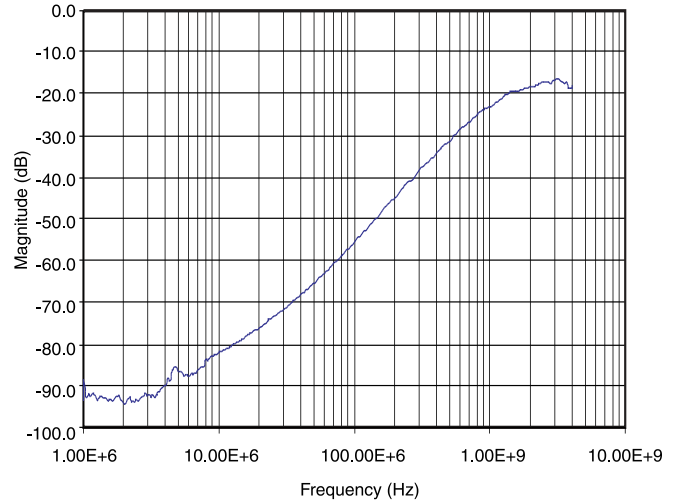

Figure 2. Differential Off Isolation vs Frequency

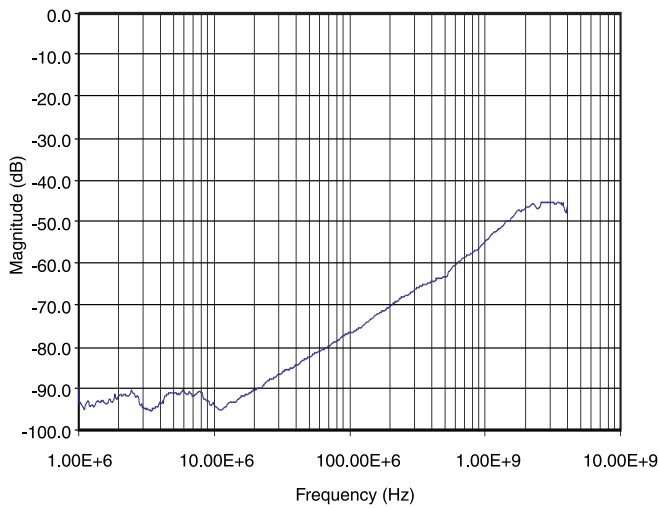

Figure 3. Differential Crosstalk vs Frequency

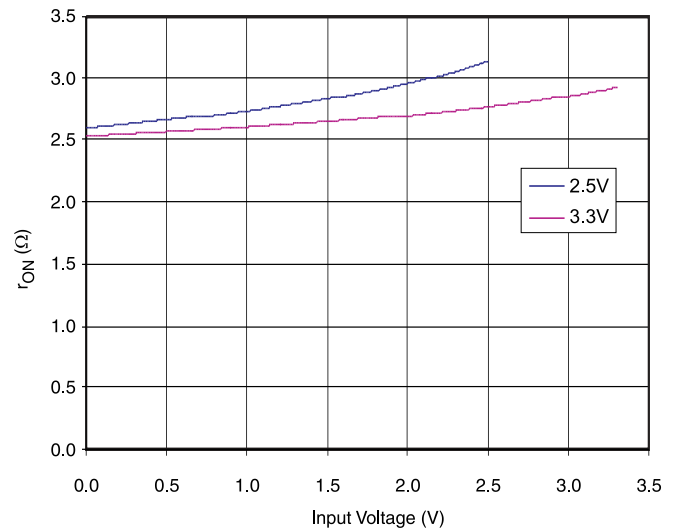

Figure 4.  $r_{ON}$  vs  $V_{COM}$  (Differential Switch)

APPLICATION INFORMATION

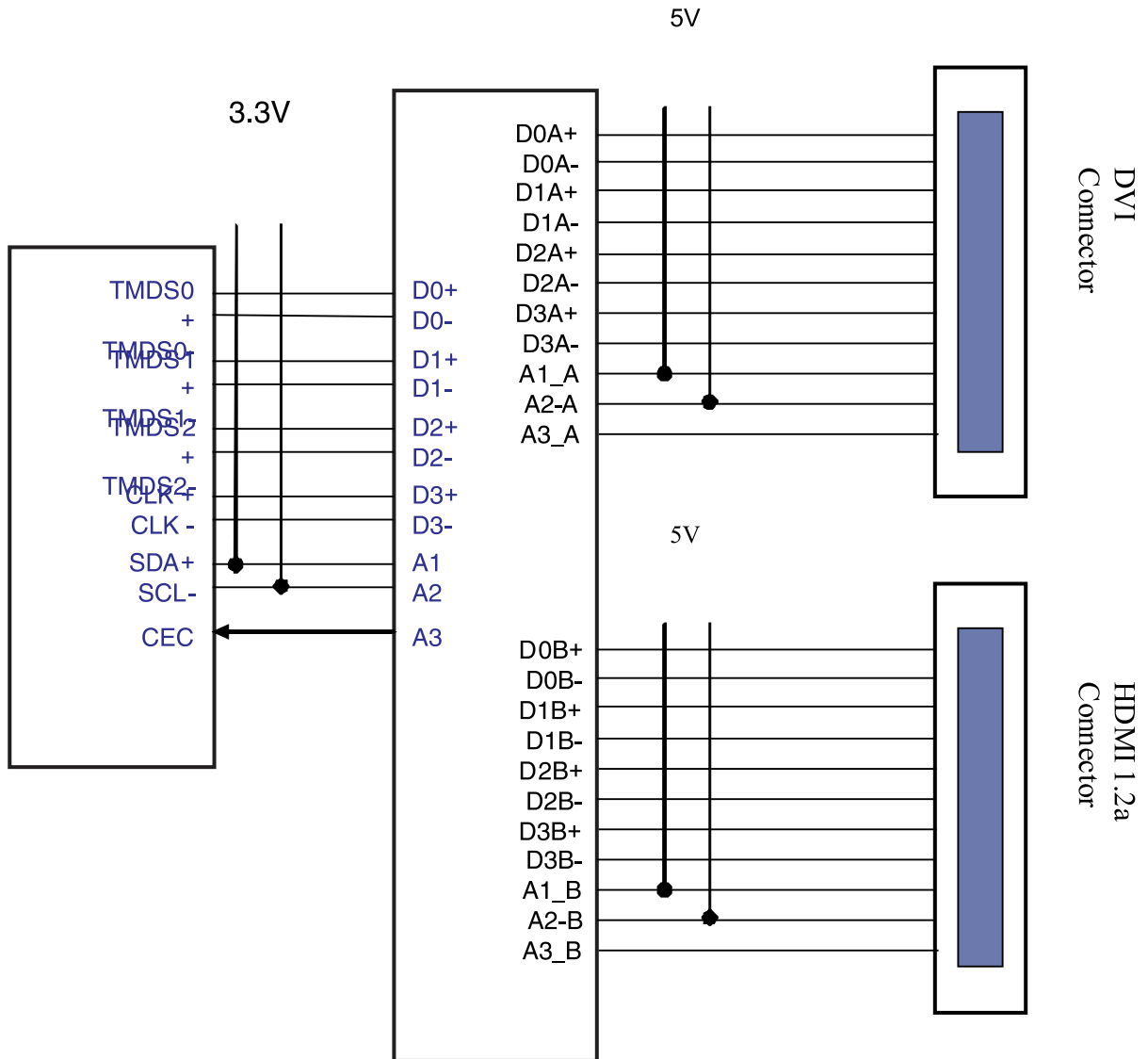

Figure 5. Typical Application Switching HDMI 1.2a and DVI



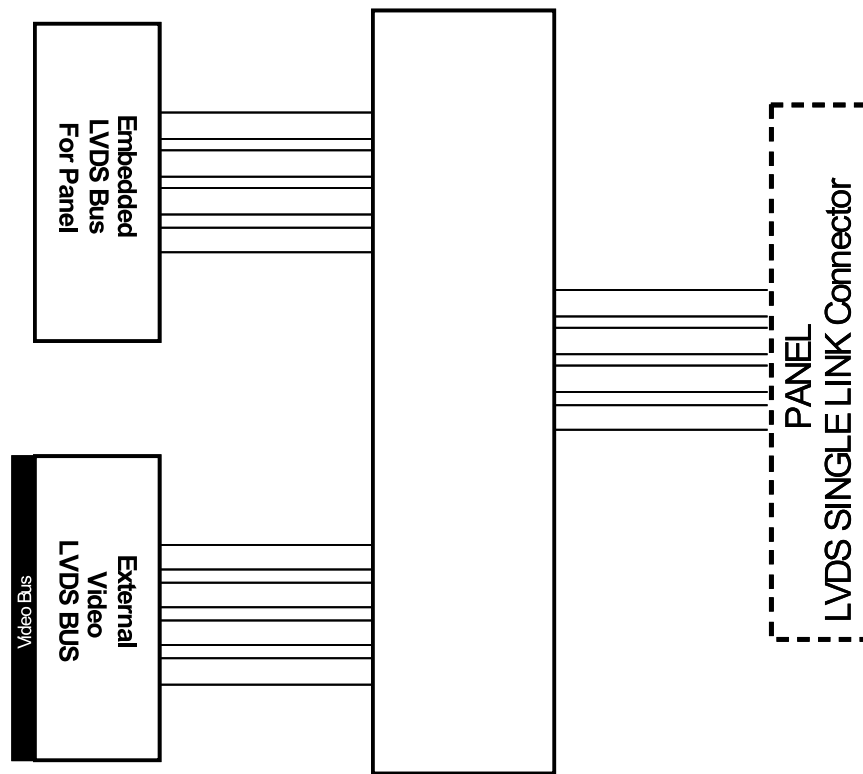
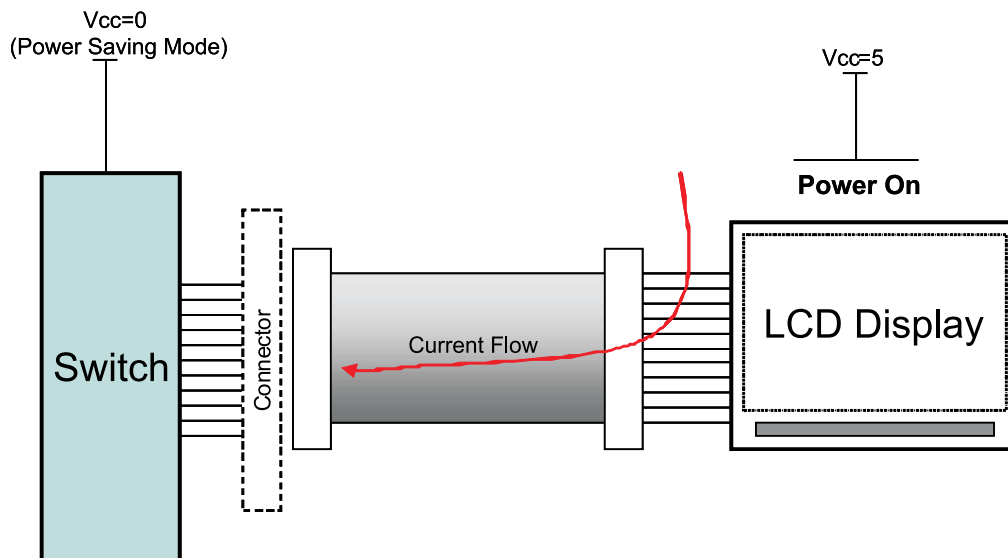

Figure 6. Typical Application for Dual LVDS



- A. The switch already has  $I_{OFF}$  circuit and it will reduce the current flow leakage limit to 10  $\mu A$  maximum and it will prevent the damage from back drive current flow from the power-on circuit.

Figure 7.  $I_{OFF}$  (Back Drive Protection)

PARAMETER MEASUREMENT INFORMATION

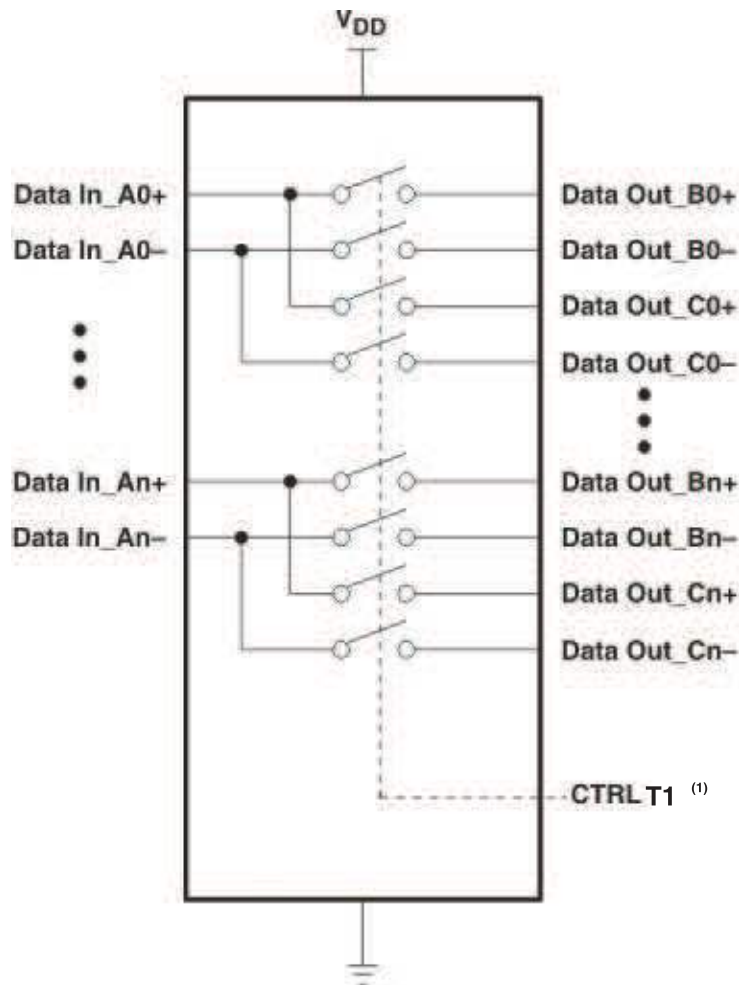

TEST PATH	T1 <sup>(1)</sup>
Data In_An=Data Out_Bn	GND
Data In_An=Data Out_Cn	V <sub>DD</sub>

(1) T1 is an external terminal.

Figure 8. Differential Signaling Device

PARAMETER MEASUREMENT INFORMATION (continued)

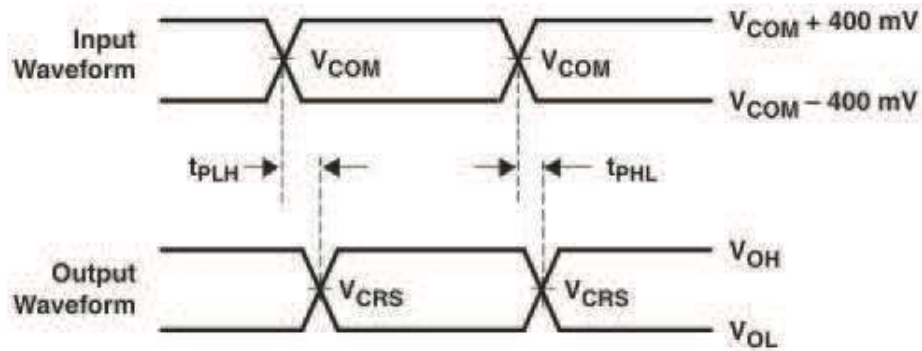
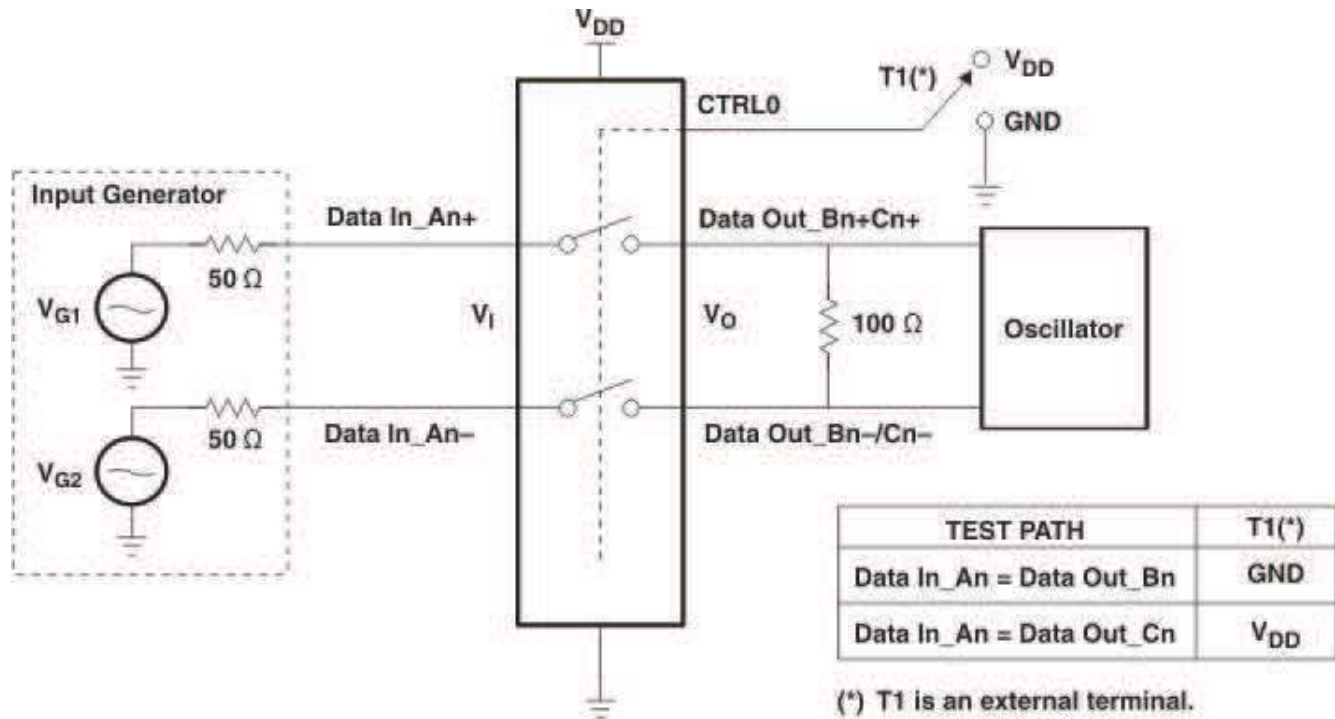

$$V_{COM} = 1.5\ \text{V}$$

$V_{CRS}$  is the cross-point of the differential signal.

$$t_{sk} = |t_{PLHn} - t_{PHLn}|$$

Figure 9. Test Circuit for Propagation Delay and Intra-Pair Skew

PARAMETER MEASUREMENT INFORMATION (continued)

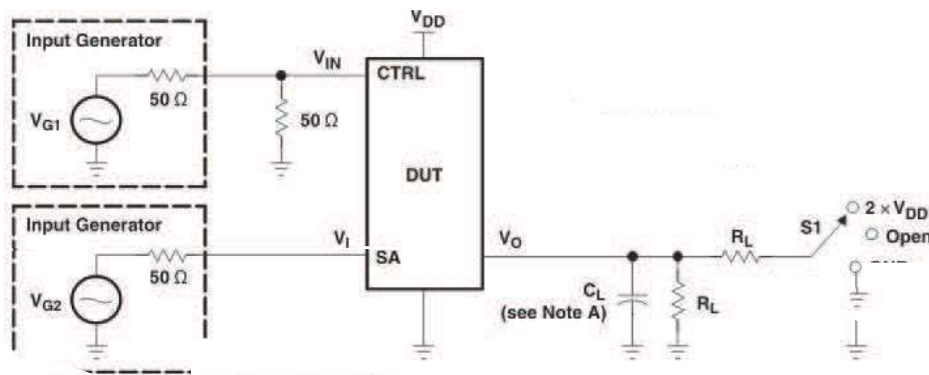

TEST	V <sub>DD</sub>	S1	R <sub>L</sub>	V <sub>i</sub>	C <sub>L</sub>	V <sub>A</sub>
t <sub>PLZ</sub> /t <sub>PZL</sub>	3.3 V ±300 mV	2 × V <sub>DD</sub>	100 Ω	GND	No load	0.3 V
t <sub>PZH</sub> /t <sub>PZH</sub>	3.3 V ±300 mV	GND	100 Ω	V <sub>DD</sub>	No load	0.3 V

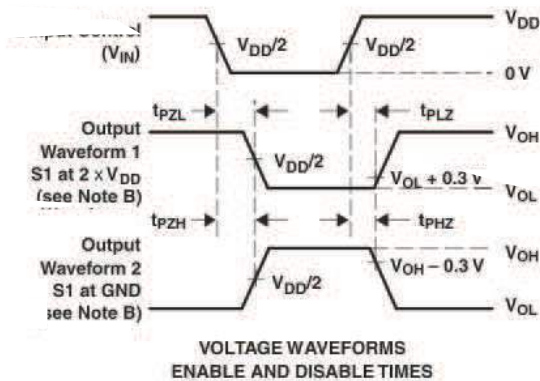

VOLTAGE WAVEFORMS  
ENABLE AND DISABLE TIMES

- A. CL includes probe and jig capacitance.
- B. Waveform 1 is for an output with internal conditions such that the output is low, except when disabled by the output control. Waveform 2 is for an output with internal conditions such that the output is high, except when disabled by the output control.
- C. All input pulses are supplied by generators having the following characteristics: PRR ≤ 10 MHz, ZO = 50 ohm, tr ≤ 2.5 ns, tf ≤ 2.5 ns
- D. The outputs are measured one at a time, with one transition per measurement.
- E. t<sub>PLZ</sub> and t<sub>PHZ</sub> are the same as t<sub>dis</sub>.
- F. t<sub>PZL</sub> and t<sub>PZH</sub> are the same as t<sub>en</sub>.

Figure 10. Test Circuit and Voltage Waveforms

PARAMETER MEASUREMENT INFORMATION (continued)

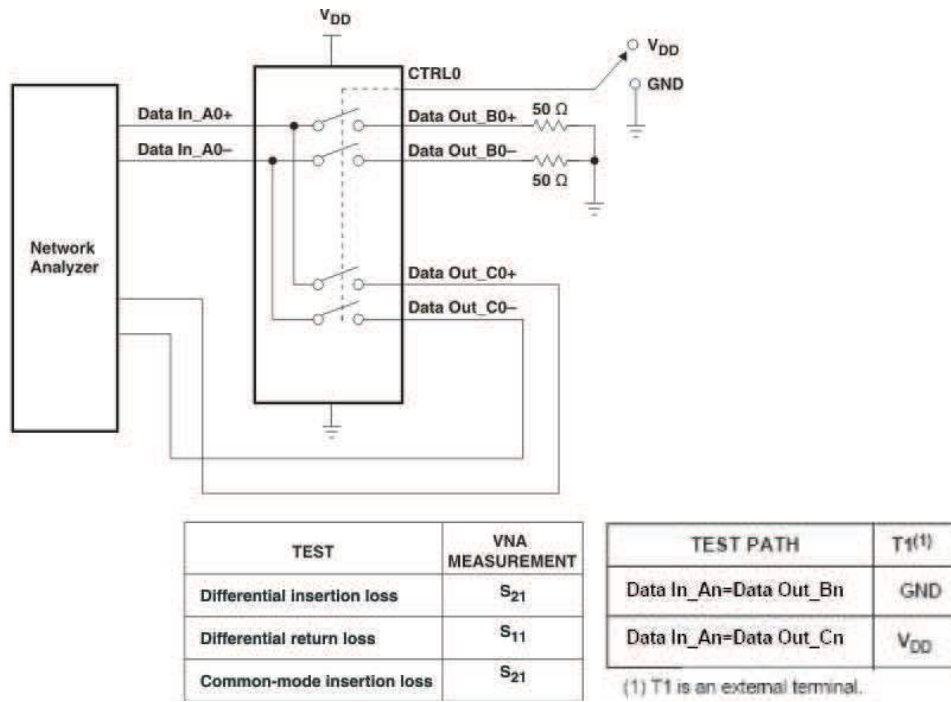
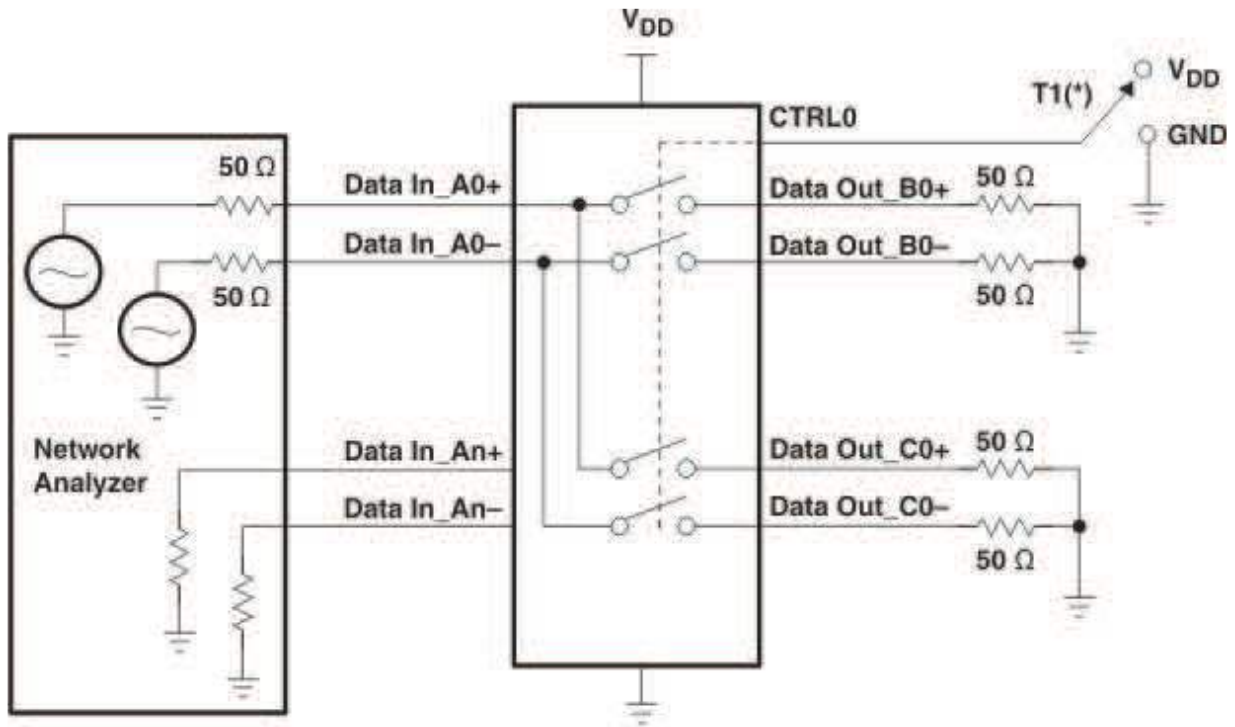

Figure 11. Differential Crosstalk Test Circuit

PARAMETER MEASUREMENT INFORMATION (continued)



(\* ) T1 is an external terminal.

TEST PATH	T1 <sup>(*)</sup>
Data In_An=Data Out_Bn	GND
Data In_An=Data Out_Cn	V <sub>DD</sub>

(1) T1 is an external terminal.

Figure 12. Differential OFF Isolation Test Circuit

PARAMETER MEASUREMENT INFORMATION (continued)

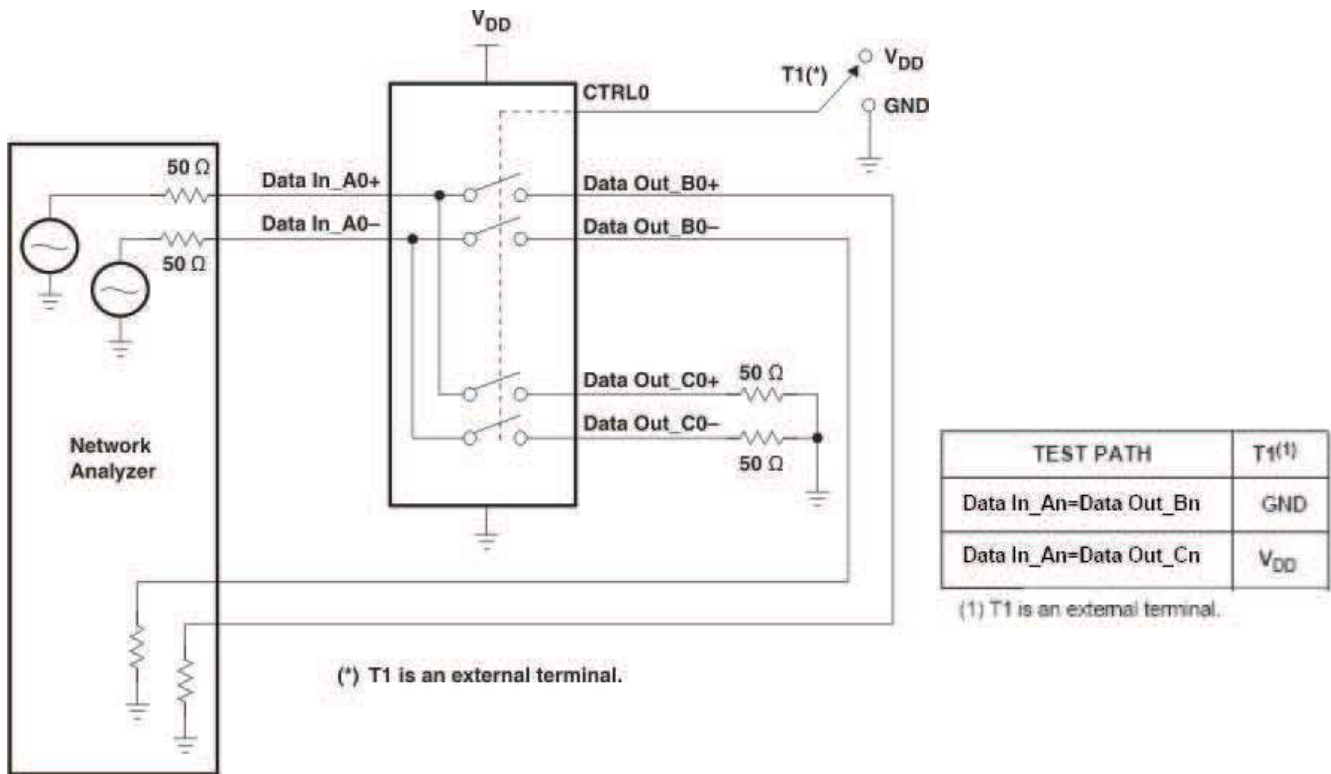

Figure 13. Differential Insertion Loss, Return Loss, and Common-Mode Insertion Loss Test Circuit

**PACKAGING INFORMATION**

Orderable Device	Status (1)	Package Type	Package Drawing	Pins	Package Qty	Eco Plan (2)	Lead finish/ Ball material (6)	MSL Peak Temp (3)	Op Temp (°C)	Device Marking (4/5)	Samples
TS3DV20812RHHR	ACTIVE	VQFN	RHH	36	2500	RoHS & Green	NIPDAU	Level-3-260C-168 HR	-40 to 85	SY812	Samples

(1) The marketing status values are defined as follows:

**ACTIVE:** Product device recommended for new designs.

**LIFEBUY:** TI has announced that the device will be discontinued, and a lifetime-buy period is in effect.

**NRND:** Not recommended for new designs. Device is in production to support existing customers, but TI does not recommend using this part in a new design.

**PREVIEW:** Device has been announced but is not in production. Samples may or may not be available.

**OBSOLETE:** TI has discontinued the production of the device.

(2) **RoHS:** TI defines "RoHS" to mean semiconductor products that are compliant with the current EU RoHS requirements for all 10 RoHS substances, including the requirement that RoHS substance do not exceed 0.1% by weight in homogeneous materials. Where designed to be soldered at high temperatures, "RoHS" products are suitable for use in specified lead-free processes. TI may reference these types of products as "Pb-Free".

**RoHS Exempt:** TI defines "RoHS Exempt" to mean products that contain lead but are compliant with EU RoHS pursuant to a specific EU RoHS exemption.

**Green:** TI defines "Green" to mean the content of Chlorine (Cl) and Bromine (Br) based flame retardants meet JS709B low halogen requirements of <=1000ppm threshold. Antimony trioxide based flame retardants must also meet the <=1000ppm threshold requirement.

(3) MSL, Peak Temp. - The Moisture Sensitivity Level rating according to the JEDEC industry standard classifications, and peak solder temperature.

(4) There may be additional marking, which relates to the logo, the lot trace code information, or the environmental category on the device.

(5) Multiple Device Markings will be inside parentheses. Only one Device Marking contained in parentheses and separated by a "-" will appear on a device. If a line is indented then it is a continuation of the previous line and the two combined represent the entire Device Marking for that device.

(6) Lead finish/Ball material - Orderable Devices may have multiple material finish options. Finish options are separated by a vertical ruled line. Lead finish/Ball material values may wrap to two lines if the finish value exceeds the maximum column width.

**Important Information and Disclaimer:** The information provided on this page represents TI's knowledge and belief as of the date that it is provided. TI bases its knowledge and belief on information provided by third parties, and makes no representation or warranty as to the accuracy of such information. Efforts are underway to better integrate information from third parties. TI has taken and continues to take reasonable steps to provide representative and accurate information but may not have conducted destructive testing or chemical analysis on incoming materials and chemicals. TI and TI suppliers consider certain information to be proprietary, and thus CAS numbers and other limited information may not be available for release.

In no event shall TI's liability arising out of such information exceed the total purchase price of the TI part(s) at issue in this document sold by TI to Customer on an annual basis.



## TAPE AND REEL INFORMATION

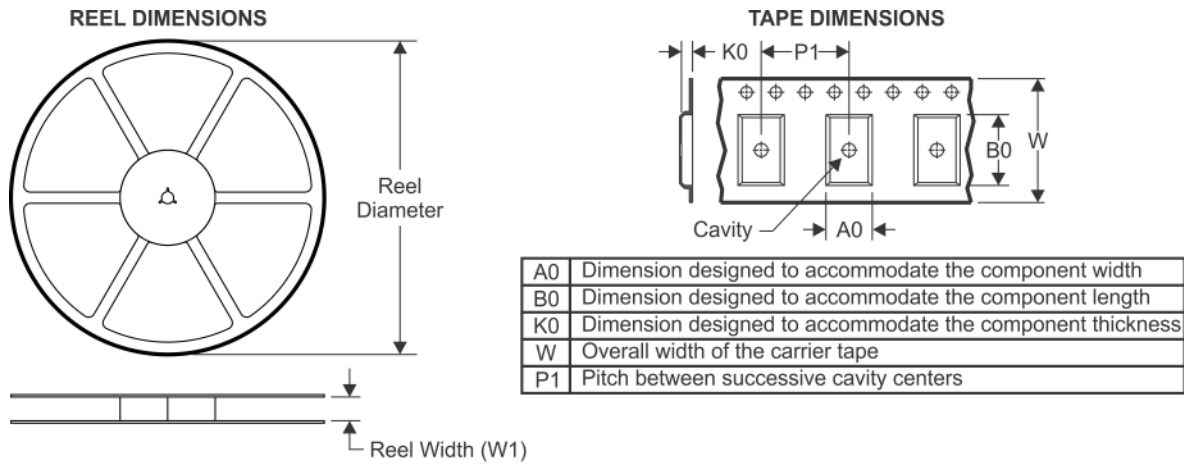

### QUADRANT ASSIGNMENTS FOR PIN 1 ORIENTATION IN TAPE

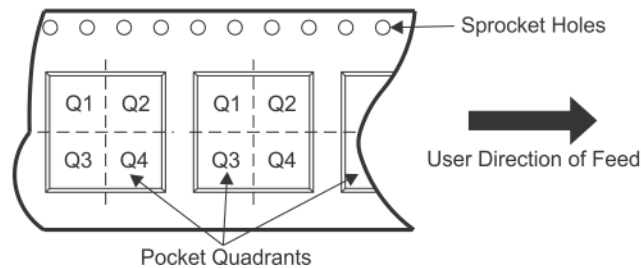

\*All dimensions are nominal

Device	Package Type	Package Drawing	Pins	SPQ	Reel Diameter (mm)	Reel Width W1 (mm)	A0 (mm)	B0 (mm)	K0 (mm)	P1 (mm)	W (mm)	Pin1 Quadrant
TS3DV20812RHHR	VQFN	RHH	36	2500	330.0	16.4	6.3	6.3	1.1	12.0	16.0	Q2

TAPE AND REEL BOX DIMENSIONS

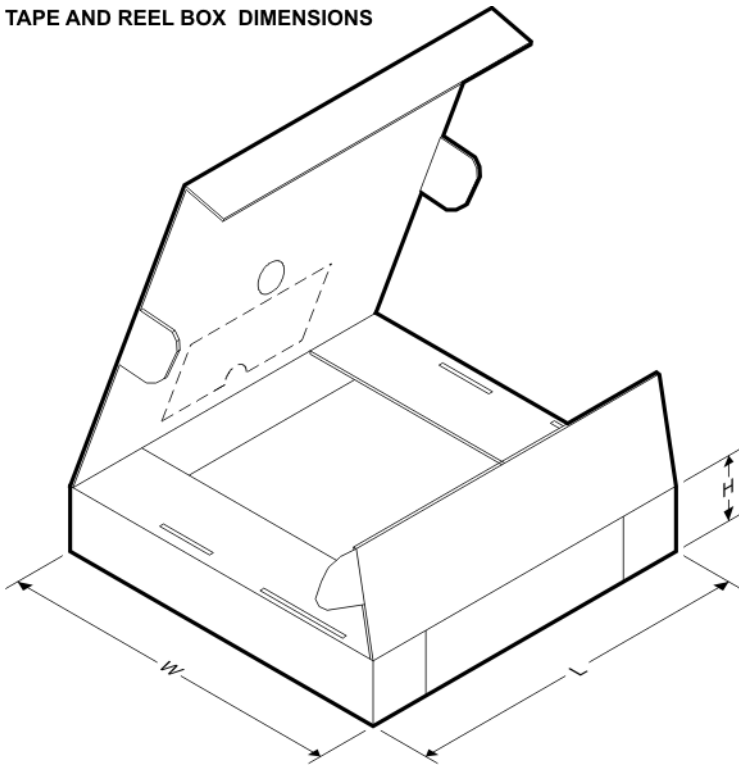

\*All dimensions are nominal

Device	Package Type	Package Drawing	Pins	SPQ	Length (mm)	Width (mm)	Height (mm)
TS3DV20812RHHR	VQFN	RHH	36	2500	367.0	367.0	38.0

## GENERIC PACKAGE VIEW

**RHH 36**

**VQFN - 1 mm max height**

6 x 6, 0.5 mm pitch

PLASTIC QUAD FLATPACK - NO LEAD

This image is a representation of the package family, actual package may vary.  
Refer to the product data sheet for package details.

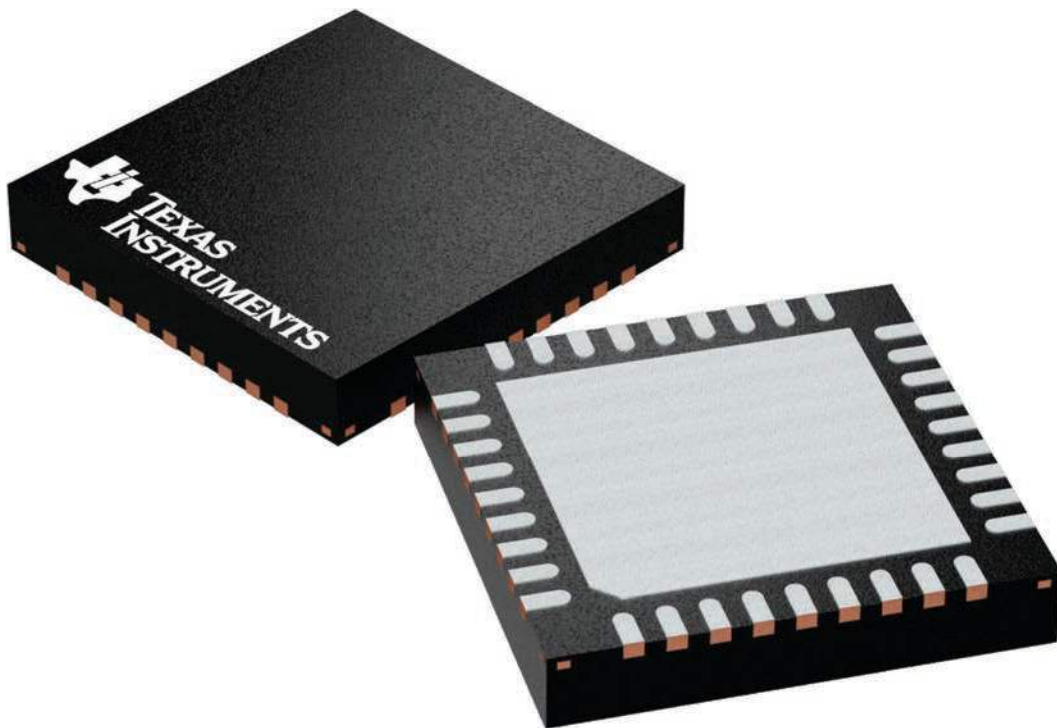

4225440/A



# EXAMPLE BOARD LAYOUT

RHH0036B

VQFN - 1 mm max height

PLASTIC QUAD FLATPACK - NO LEAD

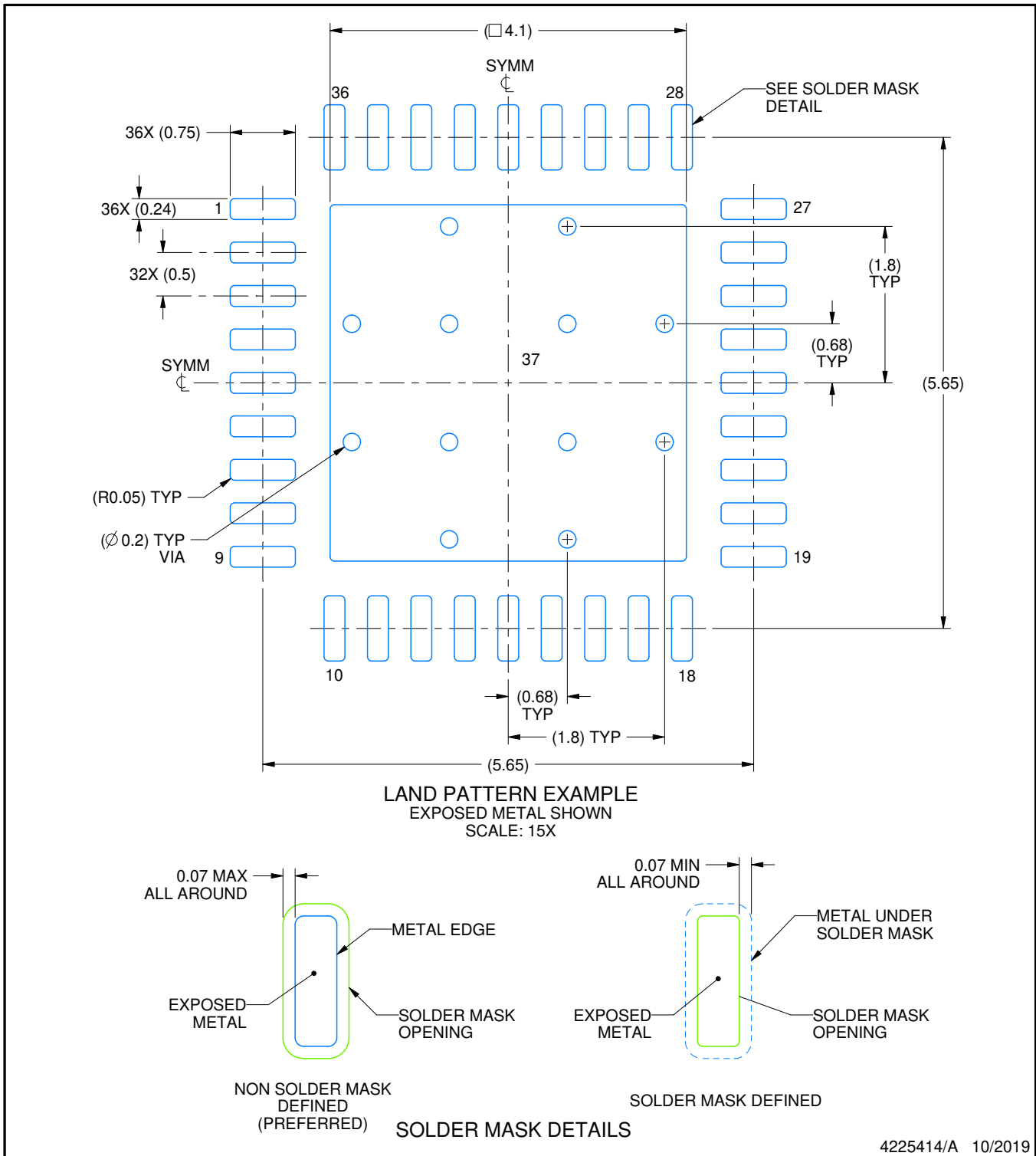

4225414/A 10/2019

NOTES: (continued)

4. This package is designed to be soldered to a thermal pad on the board. For more information, see Texas Instruments literature number SLUA271 ([www.ti.com/lit/sluea271](http://www.ti.com/lit/sluea271)).
5. Vias are optional depending on application, refer to device data sheet. If any vias are implemented, refer to their locations shown on this view. It is recommended that vias under paste be filled, plugged or tented.

# EXAMPLE STENCIL DESIGN

RHH0036B

VQFN - 1 mm max height

PLASTIC QUAD FLATPACK - NO LEAD

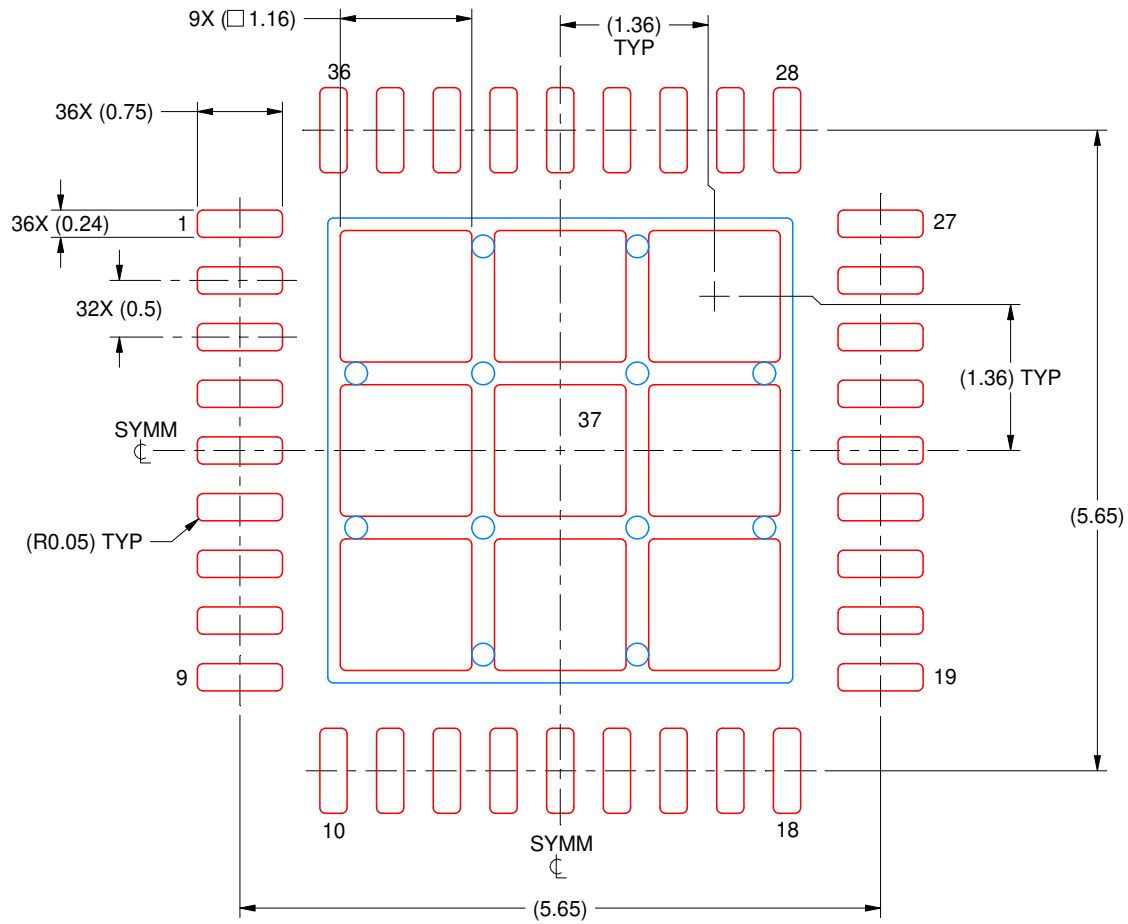

SOLDER PASTE EXAMPLE  
 BASED ON 0.125 MM THICK STENCIL  
 SCALE: 15X

EXPOSED PAD 37  
 72% PRINTED SOLDER COVERAGE BY AREA UNDER PACKAGE

4225414/A 10/2019

NOTES: (continued)

6. Laser cutting apertures with trapezoidal walls and rounded corners may offer better paste release. IPC-7525 may have alternate design recommendations.

## IMPORTANT NOTICE AND DISCLAIMER

TI PROVIDES TECHNICAL AND RELIABILITY DATA (INCLUDING DATASHEETS), DESIGN RESOURCES (INCLUDING REFERENCE DESIGNS), APPLICATION OR OTHER DESIGN ADVICE, WEB TOOLS, SAFETY INFORMATION, AND OTHER RESOURCES "AS IS" AND WITH ALL FAULTS, AND DISCLAIMS ALL WARRANTIES, EXPRESS AND IMPLIED, INCLUDING WITHOUT LIMITATION ANY IMPLIED WARRANTIES OF MERCHANTABILITY, FITNESS FOR A PARTICULAR PURPOSE OR NON-INFRINGEMENT OF THIRD PARTY INTELLECTUAL PROPERTY RIGHTS.

These resources are intended for skilled developers designing with TI products. You are solely responsible for (1) selecting the appropriate TI products for your application, (2) designing, validating and testing your application, and (3) ensuring your application meets applicable standards, and any other safety, security, or other requirements. These resources are subject to change without notice. TI grants you permission to use these resources only for development of an application that uses the TI products described in the resource. Other reproduction and display of these resources is prohibited. No license is granted to any other TI intellectual property right or to any third party intellectual property right. TI disclaims responsibility for, and you will fully indemnify TI and its representatives against, any claims, damages, costs, losses, and liabilities arising out of your use of these resources.

TI's products are provided subject to TI's Terms of Sale ([www.ti.com/legal/termsofsale.html](http://www.ti.com/legal/termsofsale.html)) or other applicable terms available either on [ti.com](http://ti.com) or provided in conjunction with such TI products. TI's provision of these resources does not expand or otherwise alter TI's applicable warranties or warranty disclaimers for TI products.

Mailing Address: Texas Instruments, Post Office Box 655303, Dallas, Texas 75265  
Copyright © 2020, Texas Instruments Incorporated