

1

2

3

4

A

A

B

B

C

C

D

D

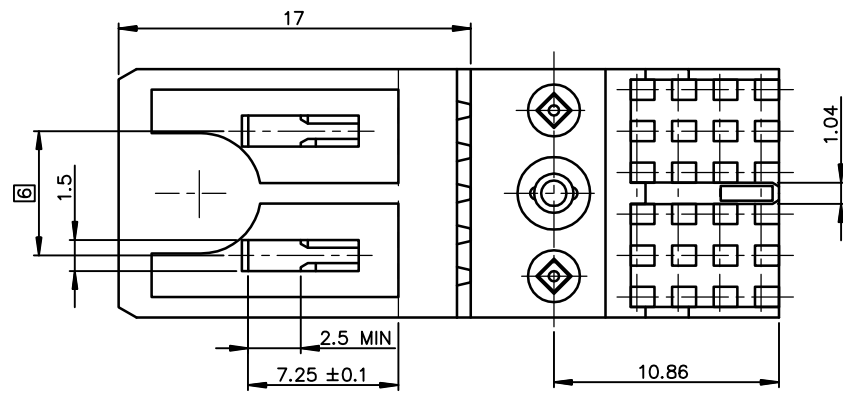

NORMINATIVE REF = IEC-61076-4-104
 NOTE-2: ONE CENTER PEG FOR HOLD DOWN FORCE
 NOTE-3: CODING RECESS FOR 8MM EXTENDED KEYS
 NOTE-4: PRODUCT MARKING = PRODUCT NUMBER + BATCH CODE + FCI
 FOR 1 MODULE SIZE, END OF PART NUMBER ONLY
 NOTE-5: CENTRAL WALL WITH END REAR SUPPORT
 NOTE-6: PACKAGING IN TRAY + COVER
 IF SUFFIX "P" IS ADDED IN P/N PACKAGING IS IN TRAYS
 BUT CONNECTOR MARKING IS WITHOUT "P"
 EXAMPLE: HM1XXXXXXXXXH6P, MARKED HM1XXXXXXXXXH6

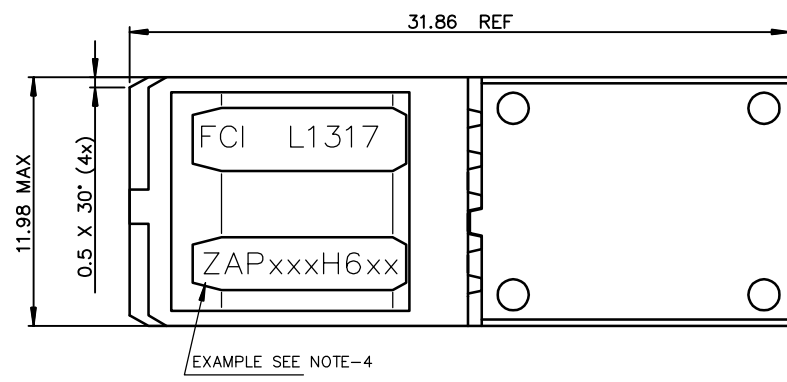
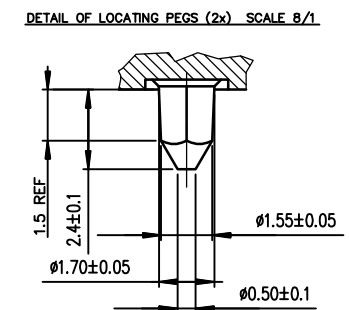
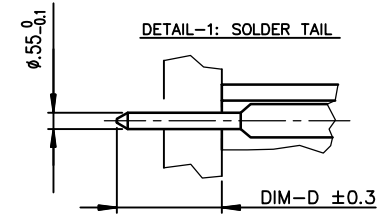
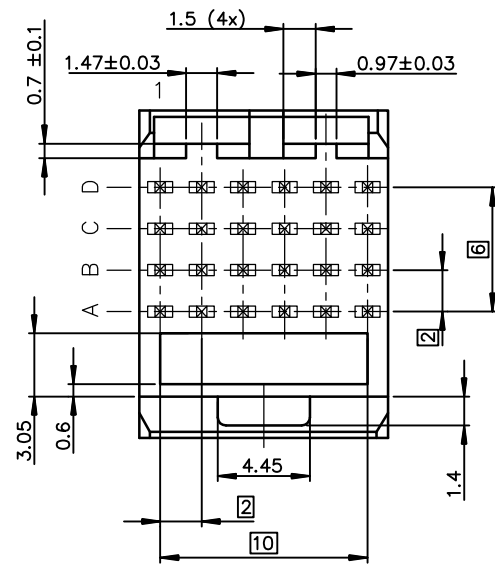
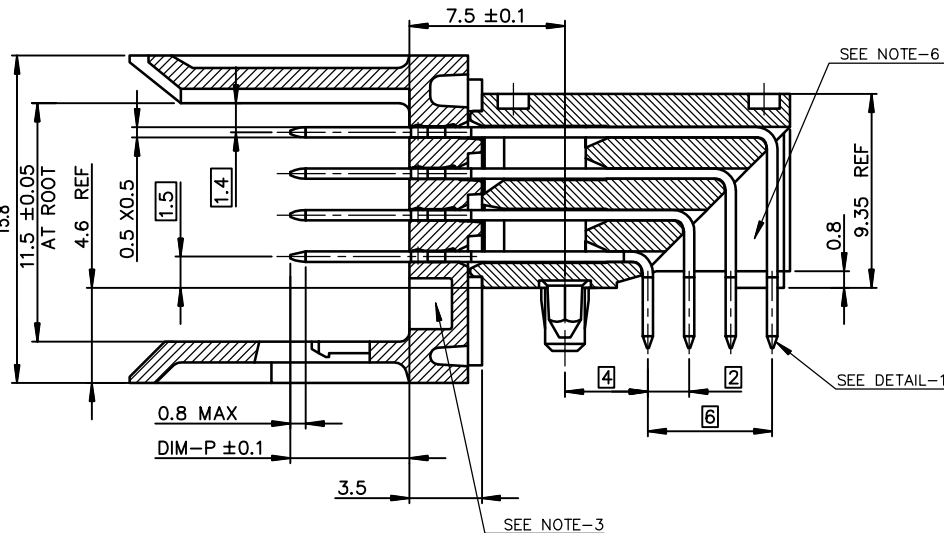

GENERAL CHARACTERISTICS AND ROHS INFORMATIONS:

SEE PRODUCT SPECIFICATION GS-12-446

OTHERS INFORMATIONS, SEE DRW C-8626-11210-2

European Views



Copyright FCI

rev	ecn no	dr	date
C	-	CHA	2003/03/18
D	LS06-0089	LGO	2006/06/06
E	LS07-0184	MLE	2007/07/27
F	DG-13365	QinDF	2012/10/07
-	-	-	-
-	-	-	-
-	-	-	-

www.fciconnect.com		surface ISO 1302 ✓	tolerance std ISO 406 ISO 1101	projection mm
TOLERANCES UNLESS OTHERWISE SPECIFIED				
Dr	CHAMPION	18/03/03	ANGULAR	0.X ± 0.1
Eng	LENOIR	18/03/03	LINEAR	0.XX ± 0.1
Chr	LEGARE	18/03/03	0.XX ± 2	0.XXX ± 0.1
Appr	LEGARE	18/03/03	Product family	METRAL
size				A3
Scale				4:1
ECN				LS07-0184
Spec ref				-
title		METRAL RA HEADER WB CONV		Rev.
4x6 CTS -STB- PUSH PEG		dwg no		C-8626-11210-1
catalog no		CUSTOMER		sheet 1 of 2

P/N: HM1L41ZAP240H6P		CTS LOADING PATTERN				
DIM-P	1	2	3	4	5	6
ROW-D	5.75	5.75	5.75	5.75	5.75	5.75
ROW-C			5.00	5.00	5.00	5.00
ROW-B				5.75	5.75	5.75
ROW-A	5.75			5.75	5.75	5.75
DIM-D = 2.9±0.3		NUMBER OF CTS = 17				
PERFORMANCE LEVEL = IEC CLASS-1		SP 240				

P/N: HM1L41ZAP240H6PLF		CTS LOADING PATTERN				
DIM-P	1	2	3	4	5	6
ROW-D	5.75	5.75	5.75	5.75	5.75	5.75
ROW-C			5.00	5.00	5.00	5.00
ROW-B				5.75	5.75	5.75
ROW-A	5.75			5.75	5.75	5.75
DIM-D = 2.9±0.3		NUMBER OF CTS = 17				
PERFORMANCE LEVEL = IEC CLASS-1		SP 240				

P/N: HM1L41AAP434H6P		CTS LOADING PATTERN				
DIM-P	1	2	3	4	5	6
ROW-D	5.00	5.00			5.00	5.00
ROW-C	5.00	5.00			5.00	5.00
ROW-B	5.00	5.00			5.00	5.00
ROW-A	5.00	5.00			5.00	5.00
DIM-D = 2.9±0.3		NUMBER OF CTS = 16				
PERFORMANCE LEVEL = IEC CLASS-1		SP 434				

P/N: HM1L41ZAP317H6P		CTS LOADING PATTERN				
DIM-P	1	2	3	4	5	6
ROW-D	5.00	5.00	5.00	5.00	5.00	5.00
ROW-C	5.00	5.00	5.00	5.00	5.00	5.00
ROW-B	5.00	5.00	5.00	5.00	5.00	5.00
ROW-A	5.00	5.00	5.00	5.00	6.50	5.00
DIM-D = 2.9±0.3		NUMBER OF CTS = 24				
PERFORMANCE LEVEL = IEC CLASS-1		SP 317				

P/N: HM1L41ZAP317H6PLF		CTS LOADING PATTERN				
DIM-P	1	2	3	4	5	6
ROW-D	5.00	5.00	5.00	5.00	5.00	5.00
ROW-C	5.00	5.00	5.00	5.00	5.00	5.00
ROW-B	5.00	5.00	5.00	5.00	5.00	5.00
ROW-A	5.00	5.00	5.00	5.00	6.50	5.00
DIM-D = 2.9±0.3		NUMBER OF CTS = 24				
PERFORMANCE LEVEL = IEC CLASS-1		SP 317				

P/N: HM1L41AAP434H6PLF		CTS LOADING PATTERN				
DIM-P	1	2	3	4	5	6
ROW-D	5.00	5.00			5.00	5.00
ROW-C	5.00	5.00			5.00	5.00
ROW-B	5.00	5.00			5.00	5.00
ROW-A	5.00	5.00			5.00	5.00
DIM-D = 2.9±0.3		NUMBER OF CTS = 16				
PERFORMANCE LEVEL = IEC CLASS-1		SP 434				

P/N: HM1L41AAP376H6P		CTS LOADING PATTERN				
DIM-P	1	2	3	4	5	6
ROW-D		5.00		5.00		5.00
ROW-C	5.00		5.00		5.00	
ROW-B		5.00		5.00		5.00
ROW-A	5.00		5.00		5.00	
DIM-D = 2.9±0.3		NUMBER OF CTS = 17				
PERFORMANCE LEVEL = TELCORDIA-CO		SP 376				

P/N: HM1L41AAP376H6PLF		CTS LOADING PATTERN				
DIM-P	1	2	3	4	5	6
ROW-D		5.00		5.00		5.00
ROW-C	5.00		5.00		5.00	
ROW-B		5.00		5.00		5.00
ROW-A	5.00		5.00		5.00	
DIM-D = 2.9±0.3		NUMBER OF CTS = 17				
PERFORMANCE LEVEL = TELCORDIA-CO		SP 376				

P/N: HM1L41AAP426H6P		CTS LOADING PATTERN				
DIM-P	1	2	3	4	5	6
ROW-D	5.00		5.00	5.00	5.00	5.00
ROW-C	5.00		5.00	5.00	5.00	5.00
ROW-B	5.00		5.00	5.00	5.00	5.00
ROW-A	5.00		5.00	5.00	5.00	5.00
DIM-D = 2.9±0.3		NUMBER OF CTS = 20				
PERFORMANCE LEVEL = IEC CLASS-1		SP 426				

P/N: HM1L41AAP426H6PLF		CTS LOADING PATTERN				
DIM-P	1	2	3	4	5	6
ROW-D	5.00		5.00	5.00	5.00	5.00
ROW-C	5.00		5.00	5.00	5.00	5.00
ROW-B	5.00		5.00	5.00	5.00	5.00
ROW-A	5.00		5.00	5.00	5.00	5.00
DIM-D = 2.9±0.3		NUMBER OF CTS = 20				
PERFORMANCE LEVEL = IEC CLASS-1		SP 426				

P/N: HM1L41ZAP435H6PLF		CTS LOADING PATTERN				
DIM-P	1	2	3	4	5	6
ROW-D	6.50	5.75	5.00	5.00	5.00	5.00
ROW-C	6.50	5.75	5.00	5.00	5.00	5.00
ROW-B	6.50	5.75	5.00	5.00	5.00	5.00
ROW-A	6.50	5.75	5.00	5.00	5.00	5.00
DIM-D = 2.9±0.3		NUMBER OF CTS = 24				
PERFORMANCE LEVEL = IEC CLASS-1		SP 435				

P/N: HM1L41ZAP427H6P		CTS LOADING PATTERN				
DIM-P	1	2	3	4	5	6
ROW-D	5.00		5.00	5.00	5.00	5.00
ROW-C	5.00		5.00	5.00	5.00	5.00
ROW-B		5.00	5.00	5.00	5.00	5.00
ROW-A	5.00	5.00	6.50	6.50	5.00	5.00
DIM-D = 2.9±0.3		NUMBER OF CTS = 21				
PERFORMANCE LEVEL = IEC CLASS-1		SP 427				

P/N: HM1L41ZAP427H6PLF		CTS LOADING PATTERN				
DIM-P	1	2	3	4	5	6
ROW-D	5.00		5.00	5.00	5.00	5.00
ROW-C	5.00		5.00	5.00	5.00	5.00
ROW-B		5.00	5.00	5.00	5.00	5.00
ROW-A	5.00	5.00	6.50	6.50	5.00	5.00
DIM-D = 2.9±0.3		NUMBER OF CTS = 21				
PERFORMANCE LEVEL = IEC CLASS-1		SP 427				

P/N: HM1L41ZAP433H6P		CTS LOADING PATTERN				
DIM-P	1	2	3	4	5	6
ROW-D	5.75	5.75	5.75	5.75	5.75	5.75
ROW-C	5.75	5.00	5.75	5.75	5.75	5.75
ROW-B	5.75	5.75	5.75	5.75	5.75	5.75
ROW-A	6.50	6.50	6.50	6.50	6.50	6.50
DIM-D = 2.9±0.3		NUMBER OF CTS = 24				
PERFORMANCE LEVEL = IEC CLASS-1		SP 433				

P/N: HM1L41ZAP433H6PLF		CTS LOADING PATTERN				
DIM-P	1	2	3	4	5	6
ROW-D	5.75	5.75	5.75	5.75	5.75	5.75
ROW-C	5.75	5.00	5.75	5.75	5.75	5.75
ROW-B	5.75	5.75	5.75	5.75	5.75	5.75
ROW-A	6.50	6.50	6.50	6.50	6.50	6.50
DIM-D = 2.9±0.3		NUMBER OF CTS = 24				
PERFORMANCE LEVEL = IEC CLASS-1		SP 433				

RECOMMENDED PCB LAYOUT

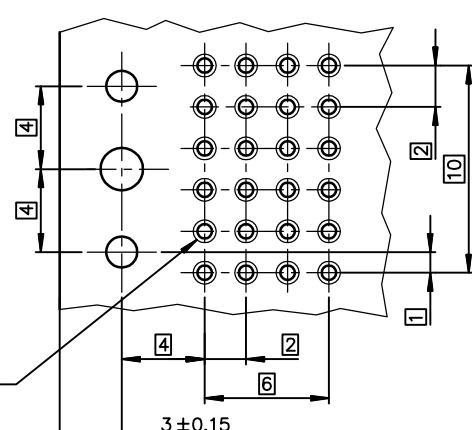

DETAIL OF CENTRAL PEG SCALE 8/1

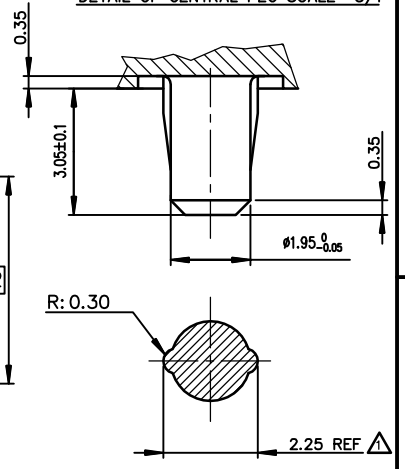

Hole according to product spec
GS-12-445 (for press-fit) ,
GS-12-446 (for STB)



Copyright FCI

OTHERS INFORMATIONS, SEE DRW C-8626-11210-1

European Views

www.fciconnect.com		surface ISO 1302	tolerance std ISO 406 ISO 1101	projection	mm
TOLERANCES UNLESS OTHERWISE SPECIFIED					
Dr	CHAMPION	18/03/03	ANGULAR	0.X	±0.1
Eng	LENOIR	18/03/03	LINEAR	0.XX	±0.1
Chr	LEGARE	18/03/03	0.XX ±2	0.XXX	±0.1
Appr	LEGARE	18/03/03	Product family	METRAL	Spec ref -
title METRAL RA HEADER WB CONVE					Rev. F
4x6 CTS -STB- PUSH PEG					
catalog no -					CUSTOMER sheet 2 of 2

rev	ecn no	dr	date
F	-	-	-
-	-	-	-
-	-	-	-
-	-	-	-
-	-	-	-
-	-	-	-
-	-	-	-