

- High Voltage fuse links for use in Air, comply with BS 2962-1 dimensions.
- Available in voltage ranges 3.6 to 72.5kV.
- Full range performance option available at 12kV and 24kV.
- Wide variety of fixing arrangements available.
- Powerful pyrotechnic striker fitted.
- E-rated North American dimension products also available.
- Suitable for indoor or outdoor use.

British Standard Range



Bussmann Fuse Links for use in air

The Bussmann range of fuse links for use in air are available in British Standard form, BS 2692, Part 1 1975. A number of options are available, including **full range capability**, and alternative fixing arrangements such as different types of tag, studs and collars etc. Details are available on application. Higher current ratings can be obtained by using fuse links in parallel and special fixing arrangements are available for this purpose.

Bussmann Air Range - USA Dimensions

A comprehensive range of 'E' rated North American Dimension fuse links for industrial applications is also available. These are the latest technology **full range fuse links** in USA Industrial Standard 2 inch and 3 inch diameter ferrule style. Extended ratings in double barrel assemblies; striker, indicator and tag versions are also available.

Selection Tables

Table of ratings for British Standard air fuses 3.6 - 72.5kV

| Part Number * | Voltage Rating | Current Rating | Breaking Capacity | Cold resistance in free air at rated current | Joule Intergral (I ² t) | | Length | Diameter Ø | Weight |
|---------------|----------------|----------------|-------------------|--|------------------------------------|------------------------|--------|------------|--------|
| | U _n | I _n | I ₁ | m Ω | A ² s | | | | |
| | kV | A | kA | | Minimum Pre-Arcing | Maximum Total Clearing | mm | mm | kg |
| 3.6ADFH*6.3 | 3.6 | 6.3 | 40 | 208 | 4.8x10 ¹ | 7.2x10 ² | 254 | 50.8 | 1.5 |
| 3.6ADFH*10 | 3.6 | 10 | 40 | 91.8 | 2.3x10 ² | 2.3x10 ³ | 254 | 50.8 | 1.5 |
| 3.6ADFH*16 | 3.6 | 16 | 40 | 31.1 | 7.2x10 ¹ | 1.0x10 ³ | 254 | 50.8 | 1.5 |
| 3.6ADFH*20 | 3.6 | 20 | 40 | 24.9 | 1.1x10 ² | 1.5x10 ³ | 254 | 50.8 | 1.5 |
| 3.6ADFH*25 | 3.6 | 25 | 40 | 18.6 | 2.0x10 ² | 2.1x10 ³ | 254 | 50.8 | 1.5 |
| 3.6ADFH*31.5 | 3.6 | 31.5 | 40 | 14.9 | 3.1x10 ² | 2.8x10 ³ | 254 | 50.8 | 1.5 |
| 3.6ADFH*40 | 3.6 | 40 | 40 | 10.0 | 7.1x10 ² | 7.7x10 ³ | 254 | 50.8 | 1.5 |
| 3.6ADGH*6.3 | 3.6 | 6.3 | 25 | 185 | 4.8x10 ¹ | 7.2x10 ² | 359 | 50.8 | 2.1 |
| 3.6ADGH*10 | 3.6 | 10 | 25 | 77.1 | 3.1x10 ² | 4.7x10 ³ | 359 | 50.8 | 2.1 |
| 3.6ADGH*16 | 3.6 | 16 | 25 | 58.6 | 5.5x10 ² | 8.3x10 ³ | 359 | 50.8 | 2.1 |
| 3.6ADGH*20 | 3.6 | 20 | 25 | 44.0 | 9.8x10 ² | 1.5x10 ⁴ | 359 | 50.8 | 2.1 |
| 3.6ADGH*25 | 3.6 | 25 | 25 | 36.9 | 1.3x10 ³ | 1.5x10 ³ | 359 | 50.8 | 2.1 |
| 3.6ADGH*31.5 | 3.6 | 31.5 | 25 | 24.6 | 2.9x10 ² | 3.5x10 ³ | 359 | 50.8 | 2.1 |
| 3.6ADGH*40 | 3.6 | 40 | 25 | 13.9 | 8.0x10 ² | 9.6x10 ³ | 359 | 50.8 | 2.1 |
| 3.6ADGH*50 | 3.6 | 50 | 25 | 9.91 | 1.6x10 ³ | 1.9x10 ⁴ | 359 | 50.8 | 2.1 |
| 3.6ADGH*63 | 3.6 | 63 | 25 | 7.05 | 3.1x10 ³ | 3.7x10 ⁴ | 359 | 50.8 | 2.1 |
| 3.6ADGH*80 | 3.6 | 80 | 25 | 4.94 | 6.3x10 ³ | 7.6x10 ⁴ | 359 | 50.8 | 2.1 |
| 3.6ADGH*100 | 3.6 | 100 | 25 | 3.96 | 9.8x10 ³ | 1.2x10 ⁵ | 359 | 50.8 | 2.1 |
| 7.2ADFH*6.3 | 7.2 | 6.3 | 20 | 206 | 4.8x10 ¹ | 5.6x10 ² | 254 | 50.8 | 1.5 |
| 7.2ADFH*10 | 7.2 | 10 | 20 | 83.0 | 7.2x10 ¹ | 9.4x10 ² | 254 | 50.8 | 1.5 |
| 7.2ADFH*16 | 7.2 | 16 | 20 | 52.3 | 7.2x10 ¹ | 8.6x10 ² | 254 | 50.8 | 1.5 |
| 7.2ADFH*20 | 7.2 | 20 | 20 | 41.8 | 1.1x10 ² | 1.5x10 ³ | 254 | 50.8 | 1.5 |
| 7.2ADFH*25 | 7.2 | 25 | 20 | 31.5 | 2.0x10 ² | 2.6x10 ³ | 254 | 50.8 | 1.5 |
| 7.2ADFH*31.5 | 7.2 | 31.5 | 20 | 22.8 | 3.8x10 ² | 4.8x10 ³ | 254 | 50.8 | 1.5 |
| 7.2ADFH*40 | 7.2 | 40 | 20 | 15.6 | 8.0x10 ² | 1.1x10 ⁴ | 254 | 50.8 | 1.5 |
| 7.2ADFH*50 | 7.2 | 50 | 20 | 11.8 | 1.3x10 ³ | 1.4x10 ⁴ | 254 | 50.8 | 1.5 |
| 7.2ADFH*63 | 7.2 | 63 | 20 | 8.41 | 2.5x10 ³ | 2.9x10 ⁴ | 254 | 50.8 | 1.5 |
| 7.2AFFH*80 | 7.2 | 80 | 20 | 5.83 | 6.3x10 ³ | 6.9x10 ⁴ | 254 | 76.2 | 2.8 |
| 7.2AFFH*100 | 7.2 | 100 | 20 | 4.38 | 9.8x10 ³ | 1.4x10 ⁵ | 254 | 76.2 | 2.8 |
| 7.2BDGH*6.3 | 7.2 | 6.3 | 40 | 206 | 5.1x10 ¹ | 6.0x10 ² | 359 | 50.8 | 2.1 |
| 7.2BDGH*10 | 7.2 | 10 | 40 | 83.0 | 1.0x10 ² | 1.3x10 ³ | 359 | 50.8 | 2.1 |
| 7.2BDGH*16 | 7.2 | 16 | 40 | 52.3 | 8.4x10 ¹ | 1.0x10 ³ | 359 | 50.8 | 2.1 |
| 7.2BDGH*20 | 7.2 | 20 | 40 | 41.8 | 1.1x10 ² | 1.5x10 ³ | 359 | 50.8 | 2.1 |
| 7.2BDGH*25 | 7.2 | 25 | 40 | 31.4 | 2.0x10 ² | 2.6x10 ³ | 359 | 50.8 | 2.1 |
| 7.2BDGH*31.5 | 7.2 | 31.5 | 40 | 22.8 | 4.6x10 ² | 5.8x10 ³ | 359 | 50.8 | 2.1 |
| 7.2BDGH*40 | 7.2 | 40 | 40 | 15.7 | 8.0x10 ² | 1.1x10 ⁴ | 359 | 50.8 | 2.1 |
| 7.2BDGH*50 | 7.2 | 50 | 40 | 11.8 | 1.6x10 ³ | 1.8x10 ⁴ | 359 | 50.8 | 2.1 |
| 7.2BDGH*63 | 7.2 | 63 | 40 | 7.48 | 3.6x10 ³ | 4.3x10 ⁴ | 359 | 50.8 | 2.1 |
| 7.2BDGH*80 | 7.2 | 80 | 40 | 5.82 | 6.4x10 ³ | 7.0x10 ⁴ | 359 | 50.8 | 2.1 |
| 7.2BFGH*90 | 7.2 | 90 | 40 | 4.72 | 1.0x10 ⁴ | 1.4x10 ⁵ | 359 | 76.2 | 4.2 |
| 7.2BFGH*100 | 7.2 | 100 | 40 | 4.05 | 1.3x10 ⁴ | 1.9x10 ⁵ | 359 | 76.2 | 4.2 |
| 7.2BFGH*125 | 7.2 | 125 | 40 | 3.15 | 1.6x10 ⁴ | 1.9x10 ⁵ | 359 | 76.2 | 4.2 |
| 7.2BFGH*140 | 7.2 | 140 | 40 | 2.57 | 2.4x10 ⁴ | 3.3x10 ⁵ | 359 | 76.2 | 4.2 |
| 7.2BFGH*160 | 7.2 | 160 | 40 | 2.35 | 2.9x10 ⁴ | 4.0x10 ⁵ | 359 | 76.2 | 4.2 |
| 12ADFH*6.3 | 12 | 6.3 | 12 | 356 | 4.8x10 ¹ | 5.0x10 ² | 254 | 50.8 | 1.5 |
| 12ADFH*10 | 12 | 10 | 12 | 89.8 | 1.3x10 ² | 2.0x10 ³ | 254 | 50.8 | 1.5 |
| 12ADFH*16 | 12 | 16 | 12 | 56.5 | 1.3x10 ² | 2.0x10 ³ | 254 | 50.8 | 1.5 |
| 12ADFH*20 | 12 | 20 | 12 | 36.2 | 3.1x10 ² | 3.5x10 ³ | 254 | 50.8 | 1.5 |
| 12ADFH*25 | 12 | 25 | 12 | 28.3 | 5.1x10 ² | 6.1x10 ³ | 254 | 50.8 | 1.5 |
| 12ADFH*31.5 | 12 | 31.5 | 12 | 22.6 | 8.0x10 ² | 9.0x10 ³ | 254 | 50.8 | 1.5 |
| 12AFFH*40 | 12 | 40 | 12 | 21.8 | 1.2x10 ³ | 1.5x10 ⁴ | 254 | 76.2 | 2.8 |
| 12AFFH*50 | 12 | 50 | 12 | 15.7 | 2.0x10 ³ | 2.5x10 ⁴ | 254 | 76.2 | 2.8 |
| 12AFFH*63 | 12 | 63 | 12 | 12.5 | 3.1x10 ³ | 3.9x10 ⁴ | 254 | 76.2 | 2.8 |
| 12BDGH*6.3 | 12 | 6.3 | 40 | 356 | 5.2x10 ¹ | 5.0x10 ² | 359 | 50.8 | 2.1 |
| 12BDGH*10 | 12 | 10 | 40 | 138 | 6.4x10 ¹ | 1.0x10 ³ | 359 | 50.8 | 2.1 |
| 12BDGH*16 | 12 | 16 | 40 | 87.0 | 6.4x10 ¹ | 1.0x10 ³ | 359 | 50.8 | 2.1 |
| 12BDGH*20 | 12 | 20 | 40 | 63.3 | 1.6x10 ² | 1.8x10 ³ | 359 | 50.8 | 2.1 |
| 12BDGH*22.4 | 12 | 22.4 | 40 | 49.7 | 2.4x10 ² | 3.0x10 ³ | 359 | 50.8 | 2.1 |
| 12BDGH*25 | 12 | 25 | 40 | 43.5 | 3.2x10 ² | 3.8x10 ³ | 359 | 50.8 | 2.1 |
| 12BDGH*31.5 | 12 | 31.5 | 40 | 32.6 | 5.8x10 ² | 6.5x10 ³ | 359 | 50.8 | 2.1 |
| 12BDGH*35.5 | 12 | 35.5 | 40 | 24.5 | 9.0x10 ² | 1.1x10 ⁴ | 359 | 50.8 | 2.1 |
| 12BDGH*40 | 12 | 40 | 40 | 21.8 | 1.2x10 ³ | 1.5x10 ⁴ | 359 | 50.8 | 2.1 |
| 12BDGH*45 | 12 | 45 | 40 | 17.5 | 1.8x10 ³ | 2.3x10 ⁴ | 359 | 50.8 | 2.1 |
| 12BDGH*50 | 12 | 50 | 40 | 14.5 | 2.5x10 ³ | 3.2x10 ⁴ | 359 | 50.8 | 2.1 |
| 12BFGH*56 | 12 | 56 | 40 | 14.6 | 2.9x10 ³ | 3.7x10 ⁴ | 359 | 76.2 | 4.2 |
| 12BFGH*63 | 12 | 63 | 40 | 12.8 | 3.4x10 ³ | 4.5x10 ⁴ | 359 | 76.2 | 4.2 |
| 12BFGH*71 | 12 | 71 | 40 | 10.6 | 4.6x10 ³ | 6.3x10 ⁴ | 359 | 76.2 | 4.2 |
| 12BFGH*80 | 12 | 80 | 40 | 9.73 | 6.1x10 ³ | 7.8x10 ⁴ | 359 | 76.2 | 4.2 |
| 12BFGH*90 | 12 | 90 | 40 | 8.37 | 8.1x10 ³ | 1.0x10 ⁵ | 359 | 76.2 | 4.2 |
| 12BFGH*100 | 12 | 100 | 40 | 6.88 | 1.1x10 ⁴ | 1.4x10 ⁵ | 359 | 76.2 | 4.2 |
| 12AKGH*112 | 12 | 112 | 20 | 5.25 | 1.5x10 ⁴ | 1.9x10 ⁵ | 359 | 76.2 | 4.3 |
| 12AKGH*125 | 12 | 125 | 20 | 4.92 | 2.1x10 ⁴ | 2.4x10 ⁵ | 359 | 76.2 | 4.3 |

*The last letter of the ordering code on these items describes the tag required, please refer to "How to order" (page 61) for an explanation.

Table of ratings for British Standard air fuses 3.6 - 72.5kV

| Part Number | Voltage Rating | Current Rating | Breaking Capacity | Cold resistance in free air at rated current m Ω | Joule Integral (I ² t) | | Length mm | Diameter Ø mm | Weight kg |
|---------------|----------------------|---------------------|----------------------|---|-----------------------------------|------------------------|--------------|------------------|--------------|
| | U _n kV | I _n A | I ₁ kA | | A ² s | | | | |
| | | | | | Minimum Pre-Arcing | Maximum Total Clearing | | | |
| Fullrange | 12 | 10 | 40 | 90.6 | 2.7x10 ² | 4.7x10 ³ | 359 | 76.2 | 4.1 |
| 12FFGN4910 | 12 | 16 | 40 | 69.1 | 4.2x10 ² | 6.1x10 ³ | 359 | 76.2 | 4.1 |
| 12FFGN4916 | 12 | 20 | 40 | 45.6 | 9.5x10 ² | 1.1x10 ⁴ | 359 | 76.2 | 4.1 |
| 12FFGN4920 | 12 | 25 | 40 | 36.5 | 1.6x10 ³ | 1.5x10 ⁴ | 359 | 76.2 | 4.1 |
| 12FFGN4925 | 12 | 31.5 | 40 | 25.4 | 3.1x10 ³ | 2.5x10 ⁴ | 359 | 76.2 | 4.1 |
| 12FFGN4931.5 | 12 | 40 | 40 | 19.7 | 4.7x10 ³ | 3.8x10 ⁴ | 359 | 76.2 | 4.1 |
| 12FFGN4940 | 12 | 50 | 40 | 14.7 | 8.4x10 ³ | 5.6x10 ⁴ | 359 | 76.2 | 4.1 |
| 12FFGN4950 | 12 | 63 | 40 | 12.6 | 6.3x10 ³ | 5.4x10 ⁴ | 359 | 76.2 | 4.1 |
| 12FFGN4963 | | | | | | | 359 | 76.2 | 4.1 |
| 15.5BDGH*6.3 | 15.5 | 6.3 | 20 | 485 | 4.8x10 ¹ | 8.5x10 ² | 359 | 50.8 | 2.1 |
| 15.5BDGH*10 | 15.5 | 10 | 20 | 158 | 7.2x10 ¹ | 1.2x10 ³ | 359 | 50.8 | 2.1 |
| 15.5BDGH*16 | 15.5 | 16 | 20 | 99.1 | 7.2x10 ¹ | 1.2x10 ³ | 359 | 50.8 | 2.1 |
| 15.5BDGH*20 | 15.5 | 20 | 20 | 74.6 | 1.3x10 ² | 2.8x10 ³ | 359 | 50.8 | 2.1 |
| 15.5BDGH*25 | 15.5 | 25 | 20 | 54.2 | 2.4x10 ² | 4.3x10 ³ | 359 | 50.8 | 2.1 |
| 15.5BDGH*31.5 | 15.5 | 31.5 | 20 | 38.2 | 4.9x10 ² | 7.0x10 ³ | 359 | 50.8 | 2.1 |
| 15.5BDGH*40 | 15.5 | 40 | 20 | 27.2 | 9.6x10 ² | 1.2x10 ⁴ | 359 | 50.8 | 2.1 |
| 15.5BFGH*50 | 15.5 | 50 | 20 | 22.2 | 1.6x10 ³ | 3.2x10 ⁴ | 359 | 76.2 | 4.2 |
| 15.5BFGH*63 | 15.5 | 63 | 20 | 15.5 | 3.2x10 ³ | 4.6x10 ⁴ | 359 | 76.2 | 4.2 |
| 15.5BFGH*80 | 15.5 | 80 | 20 | 9.73 | 7.2x10 ³ | 1.0x10 ⁵ | 359 | 76.2 | 4.2 |
| 15.5BFGH*85 | 15.5 | 85 | 20 | 9.45 | 7.2x10 ³ | 1.0x10 ⁵ | 359 | 76.2 | 4.2 |
| 24ADIHA6.3 | 15.5 | 6.3 | 12 | 520 | 7.9x10 ¹ | 8.5x10 ² | 565 | 50.8 | 3.0 |
| 24ADIHA10 | 15.5 | 10 | 12 | 173 | 7.2x10 ¹ | 1.1x10 ³ | 565 | 50.8 | 3.0 |
| 24ADIHA16 | 15.5 | 16 | 12 | 129 | 1.3x10 ² | 1.7x10 ³ | 565 | 50.8 | 3.0 |
| 24ADIHA20 | 15.5 | 20 | 12 | 104 | 2.0x10 ² | 2.8x10 ³ | 565 | 50.8 | 3.0 |
| 24ADIHA25 | 15.5 | 25 | 12 | 82.7 | 3.1x10 ² | 4.1x10 ³ | 565 | 50.8 | 3.0 |
| 24ADIHA31.5 | 15.5 | 31.5 | 12 | 66.2 | 4.9x10 ² | 6.8x10 ³ | 565 | 50.8 | 3.0 |
| 24AFIHA40 | 24 | 40 | 16 | 46.5 | 1.2x10 ³ | 1.1x10 ⁴ | 565 | 76.2 | 6.1 |
| 24AFIHA50 | 24 | 50 | 16 | 33.2 | 2.4x10 ³ | 2.2x10 ⁴ | 565 | 76.2 | 6.1 |
| 24AFIHA63 | 24 | 63 | 16 | 23.5 | 3.2x10 ³ | 5.2x10 ⁴ | 565 | 76.2 | 6.1 |
| 24AFIHA80 | 24 | 80 | 16 | 17.9 | 5.5x10 ³ | 8.2x10 ⁴ | 565 | 76.2 | 6.1 |
| 24AFIHA90 | 24 | 90 | 16 | 14.7 | 7.2x10 ³ | 1.0x10 ⁵ | 565 | 76.2 | 6.1 |
| Fullrange | 24 | 3.15 | 35.5 | 893 | 3.1x10 ¹ | 9.8x10 ¹ | 565 | 50.8 | 3.0 |
| 24FDIHA3.15 | 24 | 5 | 35.5 | 412 | 5.9x10 ¹ | 4.5x10 ² | 565 | 50.8 | 3.0 |
| 24FDIHA5 | 24 | 6.3 | 35.5 | 412 | 5.9x10 ¹ | 4.5x10 ² | 565 | 50.8 | 3.0 |
| 24FDIHA6.3 | 24 | 10 | 35.5 | 205 | 2.7x10 ² | 2.1x10 ³ | 565 | 50.8 | 3.0 |
| 24FDIHA10 | 24 | 16 | 35.5 | 103 | 1.1x10 ³ | 8.3x10 ³ | 565 | 50.8 | 3.0 |
| 24FDIHA16 | 24 | 20 | 35.5 | 88.2 | 1.3x10 ³ | 4.8x10 ³ | 565 | 50.8 | 3.0 |
| 24FDIHA20 | 24 | 31.5 | 35.5 | 56.0 | 5.3x10 ³ | 2.0x10 ⁴ | 565 | 50.8 | 3.0 |
| 24FDIHA31.5 | 24 | | | | | | 565 | 50.8 | 3.0 |
| 36ADIHA3.15 | 36 | 3.15 | 16 | 1460 | 2.0x10 ¹ | 2.5x10 ² | 565 | 50.8 | 3.0 |
| 36ADIHA5 | 36 | 5 | 16 | 973 | 4.4x10 ¹ | 5.5x10 ² | 565 | 50.8 | 3.0 |
| 36ADIHA6.3 | 36 | 6.3 | 16 | 781 | 7.1x10 ¹ | 8.9x10 ² | 565 | 50.8 | 3.0 |
| 36ADIHA10 | 36 | 10 | 16 | 378 | 7.2x10 ¹ | 1.1x10 ³ | 565 | 50.8 | 3.0 |
| 36ADIHA16 | 36 | 16 | 16 | 190 | 1.1x10 ² | 1.7x10 ³ | 565 | 50.8 | 3.0 |
| 36ADIHA20 | 36 | 20 | 16 | 142 | 2.0x10 ² | 2.8x10 ³ | 565 | 50.8 | 3.0 |
| 36ADIHA25 | 36 | 25 | 16 | 115 | 3.1x10 ² | 4.5x10 ³ | 565 | 50.8 | 3.0 |
| 36ADIHA31.5 | 36 | 31.5 | 16 | 81.5 | 6.1x10 ² | 8.1x10 ³ | 565 | 50.8 | 3.0 |
| 36AFIHA40 | 36 | 40 | 25 | 61.5 | 1.2x10 ³ | 1.9x10 ⁴ | 565 | 76.2 | 6.1 |
| 36AFKHA50 | 36 | 50 | 25 | 54.5 | 1.9x10 ³ | 2.8x10 ⁴ | 914 | 76.2 | 9.7 |
| 36AFKHA63 | 36 | 63 | 25 | 40.6 | 3.5x10 ³ | 5.0x10 ⁴ | 914 | 76.2 | 9.7 |
| 36AFKHA71 | 36 | 71 | 25 | 32.5 | 5.5x10 ³ | 8.2x10 ⁴ | 914 | 76.2 | 9.7 |
| 72.5AFKHA3.15 | 72.5 | 3.15 | 12 | 4230 | 1.4x10 ¹ | 1.8x10 ² | 914 | 76.2 | 9.7 |
| 72.5AFKHA5 | 72.5 | 5 | 12 | 1600 | 1.1x10 ² | 1.4x10 ³ | 914 | 76.2 | 9.7 |
| 72.5AFKHA6.3 | 72.5 | 6.3 | 12 | 1200 | 1.9x10 ² | 2.5x10 ³ | 914 | 76.2 | 9.7 |
| 72.5AFKHA10 | 72.5 | 10 | 12 | 519 | 7.2x10 ² | 9.3x10 ³ | 914 | 76.2 | 9.7 |
| 72.5AFKHA16 | 72.5 | 16 | 12 | 389 | 1.3x10 ³ | 1.7x10 ⁴ | 914 | 76.2 | 9.7 |
| 72.5AFKHA20 | 72.5 | 20 | 12 | 249 | 3.1x10 ³ | 4.0x10 ⁴ | 914 | 76.2 | 9.7 |
| 72.5AFKHA25 | 72.5 | 25 | 12 | 195 | 5.1x10 ³ | 6.6x10 ⁴ | 914 | 76.2 | 9.7 |
| 72.5AFKHA31.5 | 72.5 | 31.5 | 12 | 130 | 1.0x10 ⁴ | 1.3x10 ⁵ | 914 | 76.2 | 9.7 |
| 72.5AFKHA40 | 72.5 | 40 | 12 | 92.7 | 2.0x10 ⁴ | 2.6x10 ⁵ | 914 | 76.2 | 9.7 |

Notes

- a) The fifth letter or number of the part reference denotes the end fixing arrangement.
- b) There are a wide variety of end terminations available, the most popular types, some of which have dimensional references to BS2692: Part 1, are:

- A** No Tags - Ferrule - BS Ref. FA3 - ADIHA / BS Ref. FA4 - AFIHA / BS Ref. FA5 - AFKHA
- B** Offset Tag, single bolt fixing
- C & D** Special Offset Tags, two hole fixings for Brush fuse switch equipment, BS Ref. TA3.
- F & O** Offset Tags two bolt fixing.
- 49** Centre Tags, single bolt fixing for use in Fused End Boxes.
- 6** Tags to BS2692-1 ref. TA3

| Transformer kVA | Transformer Priority Voltage | | | | | | | | |
|--------------------|------------------------------|-----------------------|-----------|-----------|-----------------------|-----------|-----------|-----------------------|-----------|
| | 6.6kV | | | 11kV | | | 13.8kV | | |
| | Fuse Type | Current Rating (A) | Rating kV | Fuse Type | Current Rating (A) | Rating kV | Fuse Type | Current Rating (A) | Rating kV |
| 200 | BDG | 31.5 | 12 | BDG | 20 | 12 | BDG | 20 | 15.5 |
| 250 | BDG | 40 | 12 | BDG | 25 | 12 | BDG | 25 | 15.5 |
| 300/315 | BDG | 50 | 12 | BDG | 31.5 | 12 | BDG | 31.5 | 15.5 |
| 400 | BFG | 63 | 12 | BDG | 40 | 12 | BDG | 40 | 15.5 |
| 500 | BFG | 80 | 12 | BDG | 50 | 12 | BFG | 50 | 15.5 |
| 630 | BFG | 90 | 12 | BFG | 63 | 12 | BFG | 63 | 15.5 |
| 750/800 | BFG | 125 | 7.2 | BFG | 71 | 12 | BFG | 63 | 15.5 |
| 1000 | BFG | 140 | 7.2 | BFG | 90 | 12 | BFG | 85 | 15.5 |
| 1250 | BFG | 160 | 7.2 | AKG | 112 | 12 | BFG | 85 ³ | 15.5 |
| 1500 | BFG | 160 ³ | 7.2 | AKG | 125 ³ | 12 | - | - | - |

■ **Selection of these fuse links has been based on a compromise between the following:**

- 1 The fuse links should withstand transformer magnetising inrush currents, taken as 12 times full load current for 0.1 seconds.
- 2 The fuse links should discriminate with the highest rating of secondary fuse link.
- 3 The fuse links should withstand periodic over-currents of up to 150% of transformer full load current.
- 4 The fuse links should operate reasonably quickly in the event of a transformer inter-turn fault or a fault in the secondary terminal zone of the transformer.

■ **Notes**

- a) The above recommendations are not generally applicable to transformers feeding motor circuits with starting currents in excess of the rated current of the fuse. In this event, please consult Bussmann.
- b) For 6.6kV transformers, 12kV Fuse Links are recommended, where the required current rating is available.
- c) Where the transformer is not subjected to periodic over-currents, a lower fuse rating may be suitable, fuse ratings marked thus, '3' are only suitable for use with the transformer sizes quoted, where significant over loading does not occur.

Fuse links for use in transformers with primary voltages of 3.3kV, 22kV and 33kV are available, please consult Bussmann application engineers for further details and a recommendation.

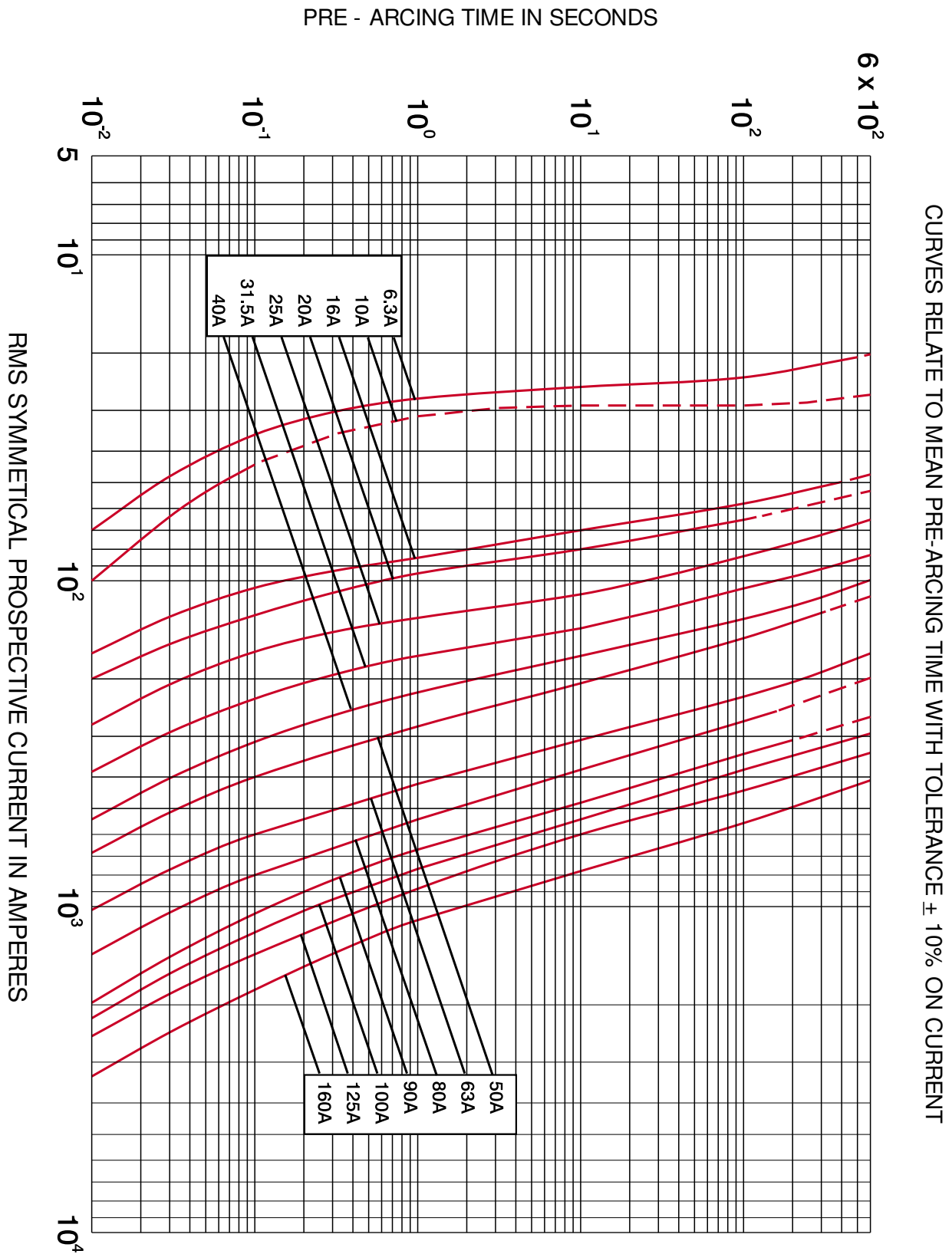

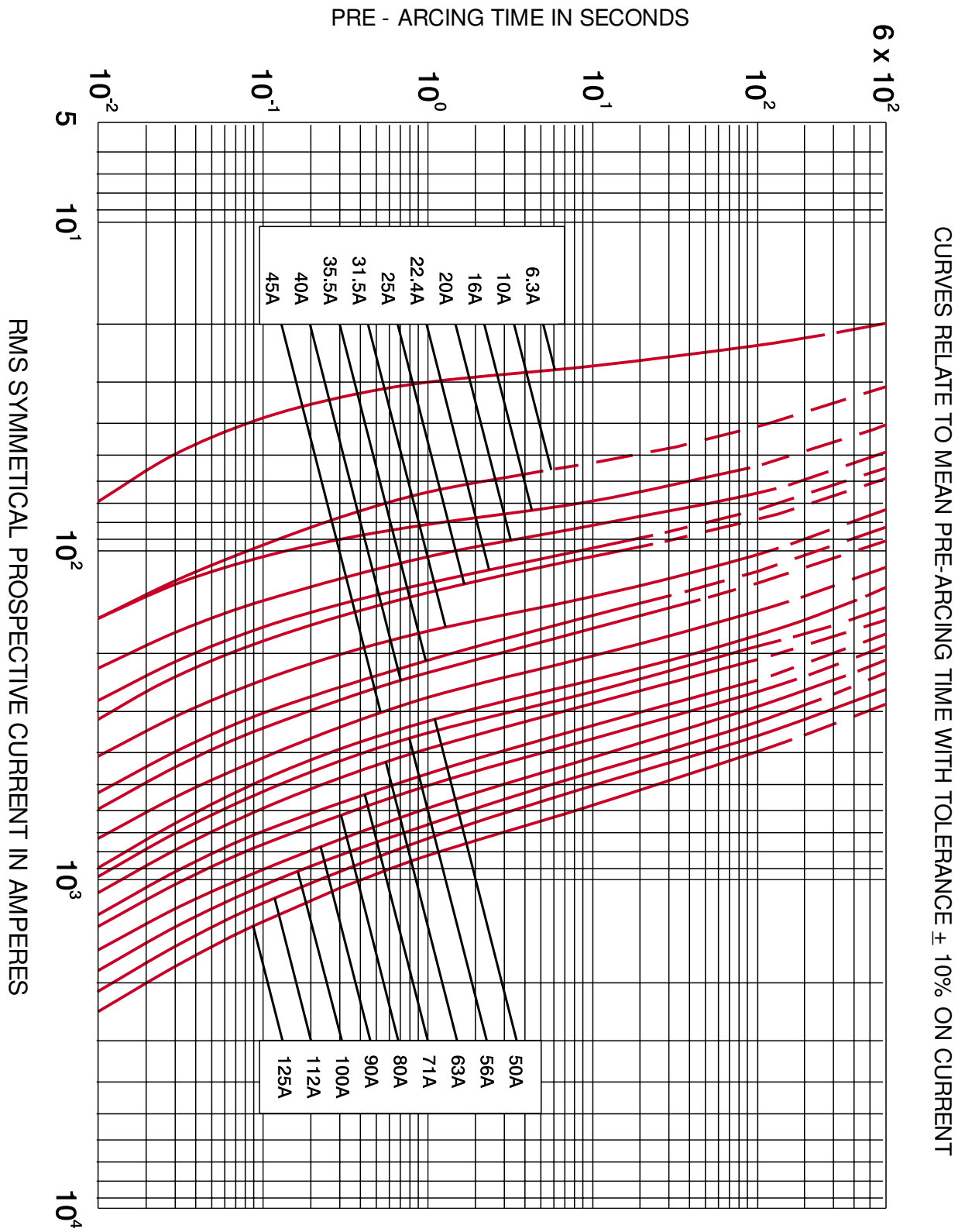

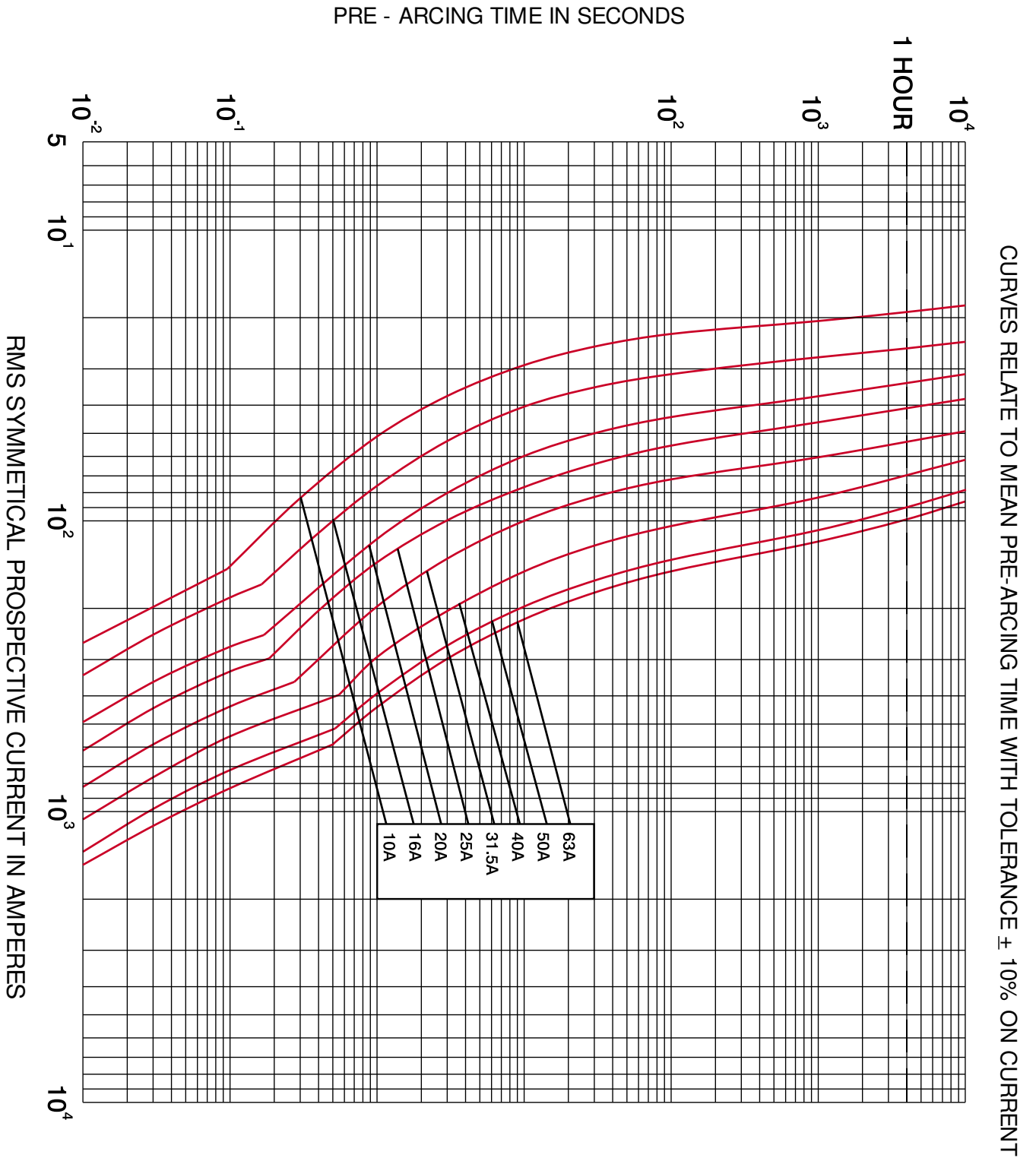

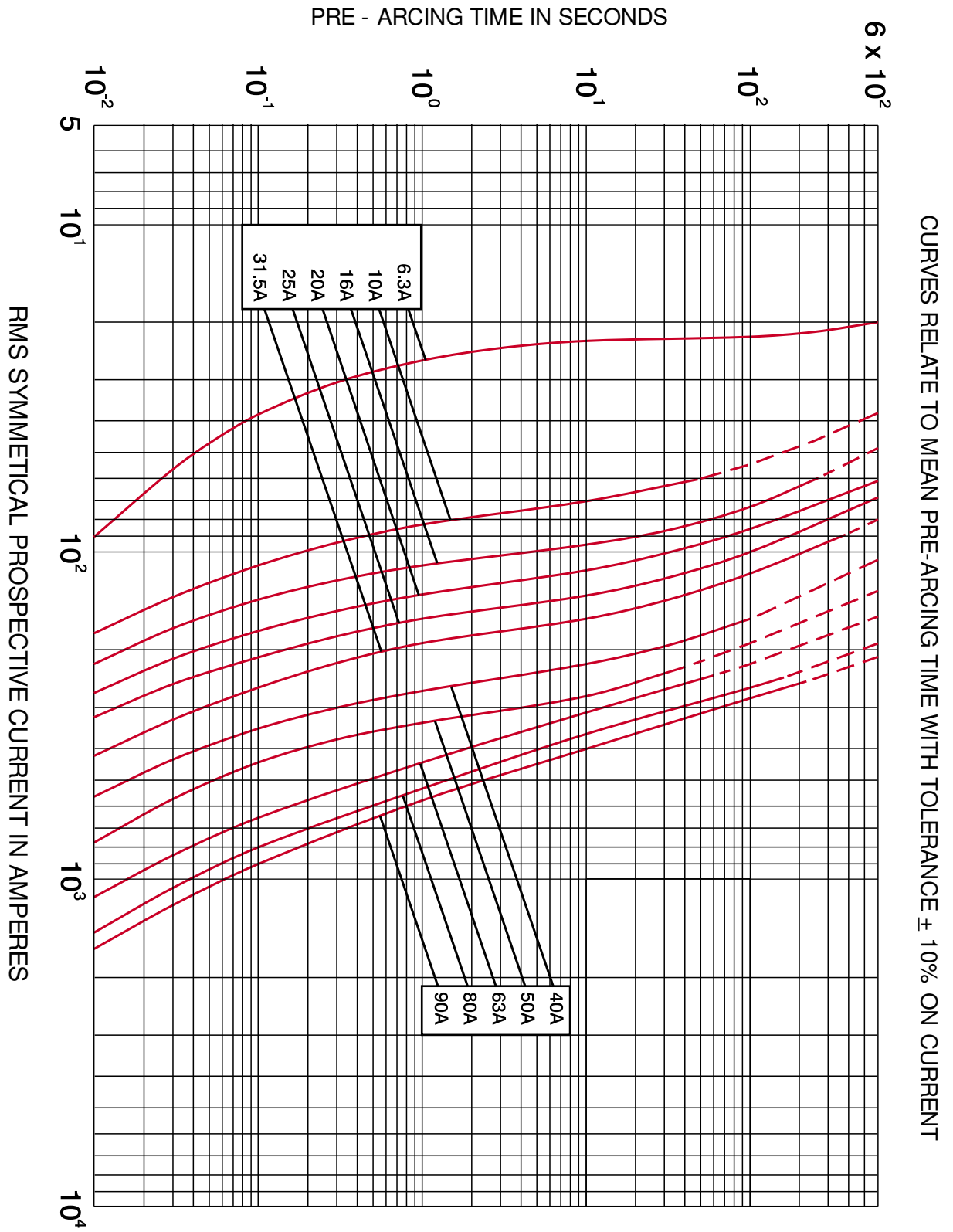

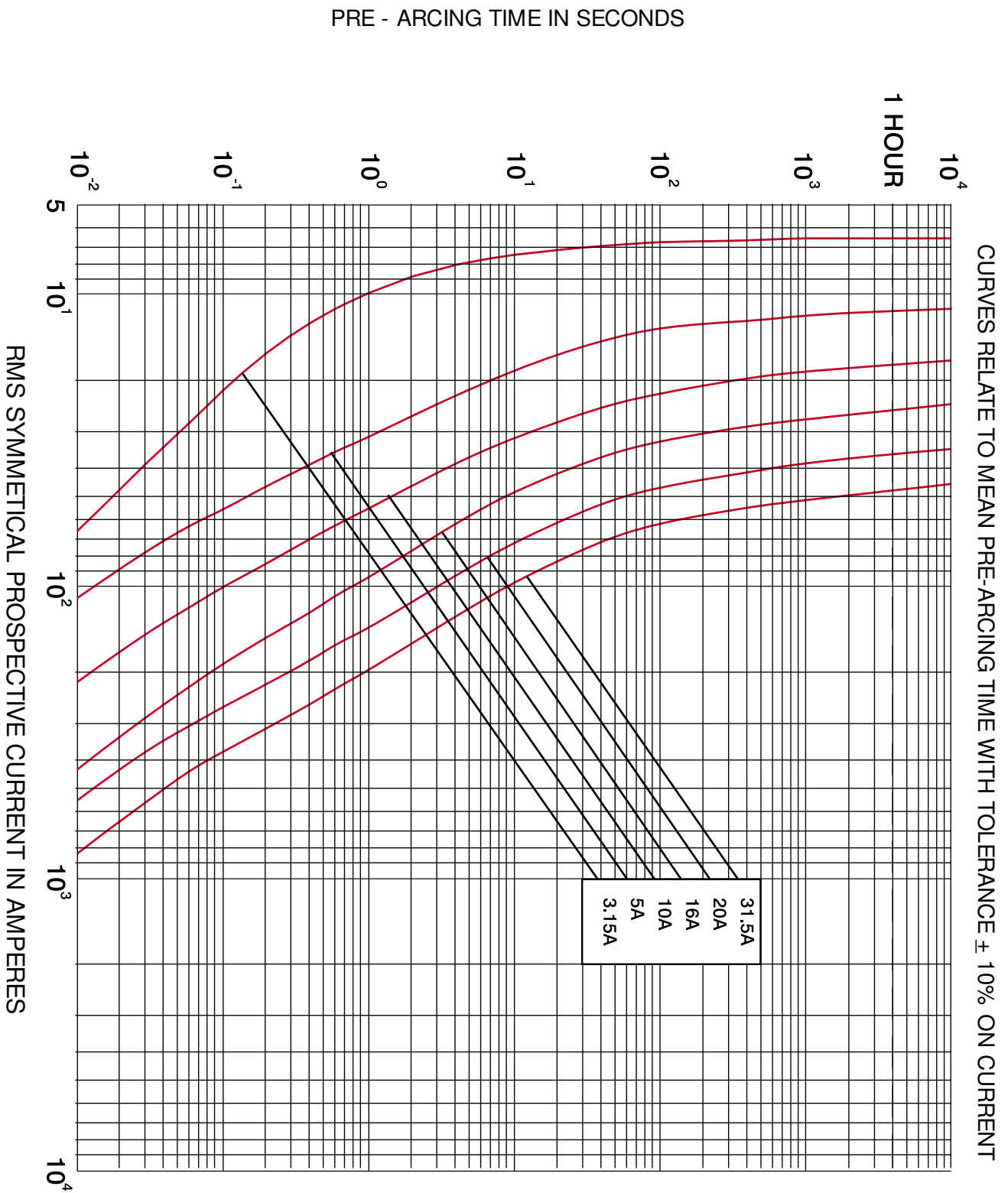

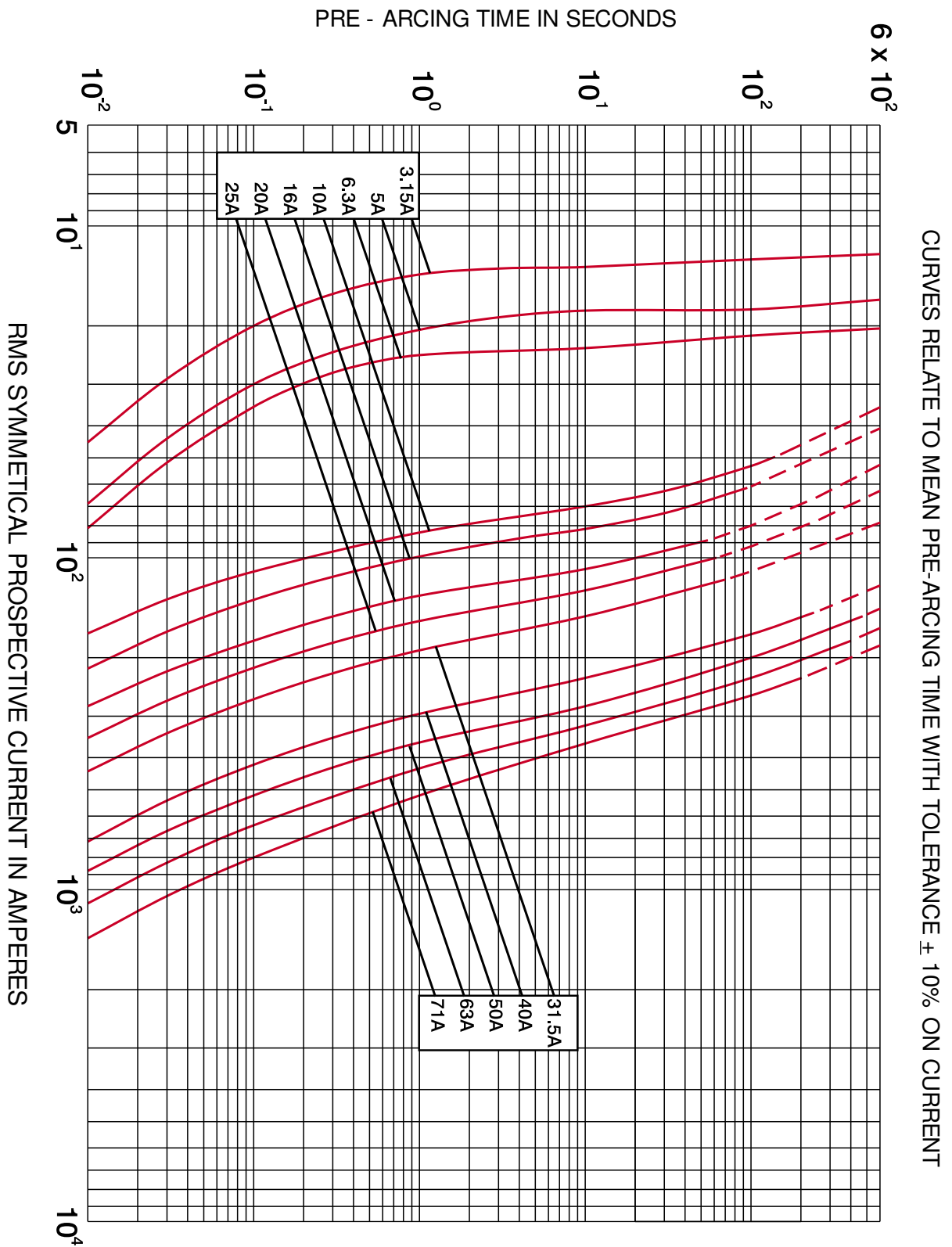

C & D Tags

| CODE | A | B | C | DØ |
|-------|-----|-----|-----|----|
| ADFHC | 356 | 314 | 254 | 51 |
| ADGHC | 461 | 419 | 359 | 51 |
| BDGHC | 461 | 419 | 359 | 51 |
| AFFHD | 356 | 314 | 254 | 76 |
| AKGHD | 461 | 419 | 359 | 76 |
| BFGHD | 461 | 419 | 359 | 76 |

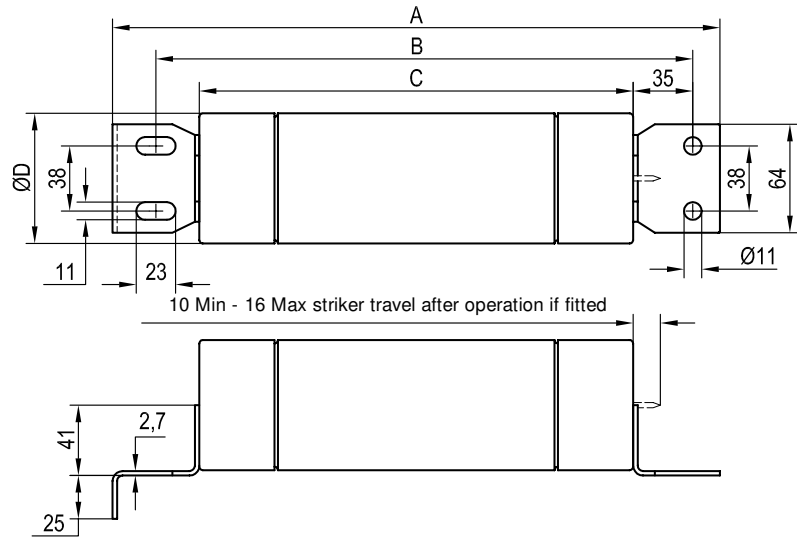

A Tags (ferrule)

| CODE | A | DØ |
|-------|-----|----|
| ADGHA | 359 | 51 |
| BDGHA | 359 | 51 |
| ADIHA | 565 | 51 |
| FDIHA | 565 | 51 |
| AKGHA | 359 | 76 |
| BFGHA | 359 | 76 |
| AFIHA | 565 | 76 |
| AKKHA | 914 | 76 |

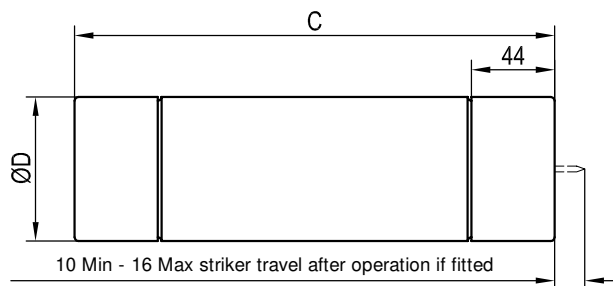

F Tags

| CODE | A | B | C | DØ |
|-------|------|-----|-----|----|
| ADFHF | 356 | 314 | 254 | 51 |
| ADGHF | 461 | 419 | 359 | 51 |
| BDGHF | 461 | 419 | 359 | 51 |
| ADIHF | 666 | 624 | 565 | 51 |
| FDIHF | 666 | 624 | 565 | 51 |
| AFFHF | 356 | 314 | 254 | 76 |
| AKGHF | 461 | 419 | 359 | 76 |
| BFGHF | 461 | 419 | 359 | 76 |
| AFIHF | 666 | 624 | 565 | 76 |
| AFKHF | 1016 | 974 | 914 | 76 |

