



Pressure sensors

Absolute pressure transducers

Series/Type: AT2 series
Ordering code:
Date: 2009-08-03
Version: 3

© EPCOS AG 2015. Reproduction, publication and dissemination of this publication, enclosures hereto and the information contained therein without EPCOS' prior express consent is prohibited.

EPCOS AG is a TDK Group Company.

Pressure sensors

Absolute pressure transducers

AT2 series

Preliminary data

Description

- The transducers are based on piezoresistive silicon pressure sensors from our own clean room.
- The robust stainless steel casing is accentuated through its excellent mechanical decoupling.

Features

- Piezoresistive MEMS technology
- Measured media:
Air, non-aggressive gases (gas humidity 0 ... 85% r.h., without dew)
Unsuitable for substances which react with glass, silicon, gold, aluminum, stainless steel, silicone glue or silicone gel.
- Wheatstone bridge with mV output, proportional to pressure and ratiometric to supply voltage
- RoHS-compatible, halogen-free
- TO39 package for PCB mounting

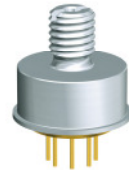

Dimensional drawings

Type TH (M5 thread connection)

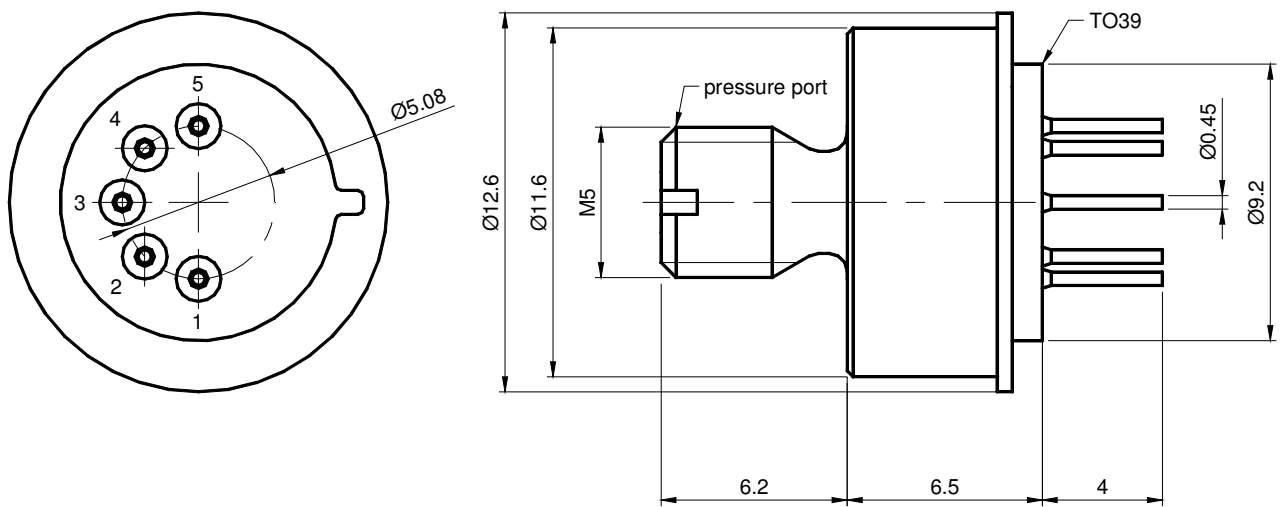

All dimensions in mm

Pressure sensors
Absolute pressure transducers
AT2 series
Preliminary data
Technical data
Absolute maximum ratings

Parameter	Symbol	Conditions	Min.	Typ.	Max.	Unit
Temperature ranges						
Storage temperature range	T_{st}	1)	-40		+125	°C
Operating temperature range	T_a	2)	-30		+85	°C
Soldering temperature	T_{solder}	<5 s (no reflow soldering)			+240	°C
Supply voltage /-current						
Supply voltage	V_{DD}	5)			10	V
DC break down voltage	V_{is}	6)	500			V

Parameter	Symbol	Conditions	Min.	Typ.	Max.	Unit
Offset / bridge resistance @ $T_a = 25\text{ °C}$, $V_{DD} = 5\text{ V}$						
Bridge resistance	R_S	(Pin 2-4)	2.6	3.3	4.0	k Ω
Offset	V_0	7)	-30	0	+30	mV
Data in temperature range @ $T_a = -30 \dots 85\text{ °C}$, $V_{DD} = 5\text{ V}$						
Temperature hysteresis		10)		± 0.1	± 0.5	% FS
Temperature coefficients of the bridge resistance	α_{RS}	11)	2.0	2.3	2.6	$10^{-3}/K$
	β_{RS}		3	5	8	$10^{-6}/K^2$
Temperature coefficients of the sensitivity	α_S	12)	-2.5	-2.2	-1.9	$10^{-3}/K$
	β_S		3	5	8	$10^{-6}/K^2$
Temperature coefficient of offset	TCV_0	13)		± 4		$\mu V/VK$

Data dependent on rated pressure @ $T_a = 25\text{ °C}$, $V_{DD} = 5\text{ V}$

Rated pressure p_r ³⁾ bar	TCV_0 ¹³⁾ Max. $\mu V/VK$	Sensitivity S ⁸⁾			Nonlinearity L ⁹⁾		Overpressure p_{ov} ⁴⁾ Min. bar
		Min. mV/bar	Typ. mV/bar	Max. mV/bar	Typ. % FS	Max. % FS	
1.600	± 10	45	70	95	± 0.2	± 0.3	4
2.500	± 10	36	49	60			5
4.000	± 10	23	31	38			6
6.000	± 10	15	21	25			9
10.00	± 10	9	12	15			15
16.00	± 10	6.4	7.8	9			24
25.00	± 10	4.1	5	5.9			37.5

Pressure sensors

Absolute pressure transducers

AT2 series

Preliminary data

Terminal assignment

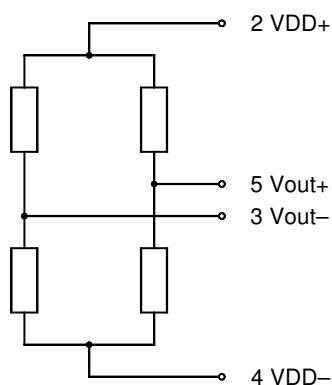

Pin	Symbol	Terminal assignment
1	n.c.	Do not connect
2	V_{DD+}	Supply voltage
3	V_{out-}	Output voltage
4	V_{DD-}	Supply voltage
5	V_{out+}	Output voltage

The polarity of V_{out} applies to positive pressure. Negative pressure or a reversed supply voltage results in a reversed polarity of the output voltage V_{out} .

Rated pressures and ordering codes

Rated pressure p_r bar	Product type	Ordering code
1.600	ATA 1.600 MA0 HG	B58610T4600A001
2.500	ATA 2.500 MA0 HG	B58610T4600A002
4.000	ATA 4.000 MA0 HG	B58610T4600A003
6.000	ATA 6.000 MA0 HG	B58610T4600A004
10.00	ATA 10.00 MA0 HG	B58610T4600A005
16.00	ATA 16.00 MA0 HG	B58610T4600A006
25.00	ATA 25.00 MA0 HG	B58610T4600A007

Preliminary data
Symbols and terms

- 1) **Storage temperature range T_{st}**
A storage of the pressure sensor within the temperature range $T_{st,min}$ up to $T_{st,max}$ and without applied pressure and supply voltage will not affect the performance of the pressure sensor.
- 2) **Operating temperature range T_a**
An operation of the pressure sensor within the temperature range $T_{a,min}$ up to $T_{a,max}$ will not affect the performance of the pressure sensor.
- 3) **Rated pressure p_r**
Within the rated pressure range 0 up to p_r the signal output characteristic corresponds to this specification.
- 4) **Overpressure p_{ov}**
Pressure cycles within the pressure range 0 up to p_{ov} will not affect the performance of the pressure sensor.
- 5) **Supply voltage V_{DD}**
 $V_{DD,max}$ is the maximum permissible supply voltage, which can be applied without damages.
The output voltage V_{out} is ratiometric ($V_{out} \sim V_{DD}$).
- 6) **DC break down voltage V_{is}**
The pressure sensor withstands a high voltage between the stainless steel pressure connection and the electrical connection V_{DD} and V_{out} (all short circuited) without damage.
- 7) **Offset V_0**
The offset V_0 is the signal output $V_{out}(p = 0)$ at zero pressure.
- 8) **Sensitivity S**
Within the pressure range 0 up to p_r the output voltage is $V_{out}(p_x) = V_0 + S \cdot p_x$
- 9) **Nonlinearity L (including pressure hysteresis)**
The nonlinearity is the deviation of the real sensor characteristic $V_{out} = f(p)$ from the ideal straight line.
It can be approximated by a polynomial of second order, with the maximum at $p_x = p_r / 2$.
The equation to calculate the nonlinearity is:

$$L = \frac{V_{out}(p_x) - V_0}{V_{out}(p_r) - V_0} - \frac{p_x}{p_r}$$

- 10) **Temperature hysteresis**
The temperature hysteresis is the change of offset, starting from the value at 25 °C after a temperature change and return to 25 °C. Determined during temperature cycles in operating temperature range (cycles with 1 K/min).
(Full Scale): $FS = V_{FS} = S \cdot p_r$
- 11) **Temperature coefficients of the bridge resistance α_{RS} , β_{RS}**
Bridge resistance at temperature T_x : $R_S(T_x) = R_S(25 \text{ °C}) \cdot [1 + \alpha_{RS} \cdot (T_x - 25 \text{ °C}) + \beta_{RS} \cdot (T_x - 25 \text{ °C})^2]$
Values are valid within the operating temperature range $T_{a,min}$ up to $T_{a,max}$
Out of the operating temperature range, the deviation may increase.
- 12) **Temperature coefficients of the sensitivity α_S , β_S**
Sensitivity at temperature T_x : $S(T_x) = S(25 \text{ °C}) \cdot [1 + \alpha_S \cdot (T_x - 25 \text{ °C}) + \beta_S \cdot (T_x - 25 \text{ °C})^2]$
Values are valid within the operating temperature range $T_{a,min}$ up to $T_{a,max}$
Out of the operating temperature range, the deviation may increase.
- 13) **Temperature coefficient of offset TCV_0**
Offset at temperature T_x : $V_0(T_x) = V_0(25 \text{ °C}) + TCV_0 \cdot (T_x - 25 \text{ °C}) \cdot V_{DD}$
Values are valid within the operating temperature range $T_{a,min}$ up to $T_{a,max}$
Out of the operating temperature range, the deviation may increase.

Preliminary data

Cautions and warnings**Storage (general)**

All pressure sensors should be stored in their original packaging. They should not be placed in harmful environments such as corrosive gases nor exposed to heat or direct sunlight, which may cause deformations. Similar effects may result from extreme storage temperatures and climatic conditions. Avoid storing the sensor dies in an environment where condensation may form or in a location exposed to corrosive gases, which will adversely affect their performance. Plastic materials should not be used for wrapping/packing when storing or transporting these dies, as they may become charged. Pressure sensor dies should be used soon after opening their seal and packaging.

Operation (general)

Media compatibility with the pressure sensors must be ensured to prevent their failure. The use of other media can cause damage and malfunction. Never use pressure sensors in atmospheres containing explosive liquids or gases.

Ensure pressure equalization to the environment, if gauge pressure sensors are used. Avoid operating the pressure sensors in an environment where condensation may form or in a location exposed to corrosive gases. These environments adversely affect their performance.

If the operating pressure is not within the rated pressure range, it may change the output characteristics. This may also happen with pressure sensor dies if an incorrect mounting method is used. Be sure that the applicable pressure does not exceed the overpressure, as it may damage the pressure sensor.

Do not exceed the maximum rated supply voltage nor the rated storage temperature range, as it may damage the pressure sensor.

Temperature variations in both the ambient conditions and the media (liquid or gas) can affect the accuracy of the output signal from the pressure sensors. Be sure to check the operating temperature range and thermal error specification of the pressure sensors to determine their suitability for the application.

Connections must be wired in accordance with the terminal assignment specified in the data sheets. Care should be taken as reversed pin connections can damage the pressure transmitters or degrade their performance. Contact between the pressure sensor terminals and metals or other materials may cause errors in the output characteristics.

Design notes (dies)

This specification describes the mechanical, electrical and physical requirements of a piezoresistive sensor die for measuring pressure. The specified parameters are valid for the pressure sensor die with pressure application either to the front or back side of the diaphragm as described in the data sheet. Pressure application to the other side may result in differing data. Most of the parameters are influenced by assembly conditions. Hence these parameters and the reliability have to be specified for each specific application and tested over its temperature range by the customer.

Handling/Mounting (dies)

Pressure sensor dies should be handled appropriately and not be touched with bare hands. They should only be picked up manually by the sides using tweezers. Their top surface should never be touched with tweezers. Latex gloves should not be used for handling them, as this will inhibit the curing of the adhesive used to bond the die to the carrier. When handling, be careful to avoid cuts caused by the sharp-edged terminals. The sensor die must not be contaminated during manufacturing processes (gluing, soldering, silk-screen process).

The package of pressure sensor dies should not to be opened until the die is mounted and should be closed after use. The sensor die must not be cleaned. The sensor die must not be damaged during the assembly process (especially scratches on the diaphragm).

Soldering (transducers, transmitters)

The thermal capacity of pressure sensors is normally low, so steps should be taken to minimize the effects of external heat. High temperatures may lead to damage or changes in characteristics.

A non-corrosive type of flux resin should normally be used and complete removal of the flux is recommended. Avoid rapid cooling due to dipping in solvent. Note that the output signal may change if pressure is applied to the terminals during soldering.

This listing does not claim to be complete, but merely reflects the experience of EPCOS AG.

Important notes

The following applies to all products named in this publication:

1. Some parts of this publication contain **statements about the suitability of our products for certain areas of application**. These statements are based on our knowledge of typical requirements that are often placed on our products in the areas of application concerned. We nevertheless expressly point out **that such statements cannot be regarded as binding statements about the suitability of our products for a particular customer application**. As a rule we are either unfamiliar with individual customer applications or less familiar with them than the customers themselves. For these reasons, it is always ultimately incumbent on the customer to check and decide whether a product with the properties described in the product specification is suitable for use in a particular customer application.
2. We also point out that **in individual cases, a malfunction of electronic components or failure before the end of their usual service life cannot be completely ruled out in the current state of the art, even if they are operated as specified**. In customer applications requiring a very high level of operational safety and especially in customer applications in which the malfunction or failure of an electronic component could endanger human life or health (e.g. in accident prevention or life-saving systems), it must therefore be ensured by means of suitable design of the customer application or other action taken by the customer (e.g. installation of protective circuitry or redundancy) that no injury or damage is sustained by third parties in the event of malfunction or failure of an electronic component.
3. **The warnings, cautions and product-specific notes must be observed.**
4. In order to satisfy certain technical requirements, **some of the products described in this publication may contain substances subject to restrictions in certain jurisdictions (e.g. because they are classed as hazardous)**. Useful information on this will be found in our Material Data Sheets on the Internet (www.tdk-electronics.tdk.com/material). Should you have any more detailed questions, please contact our sales offices.
5. We constantly strive to improve our products. Consequently, **the products described in this publication may change from time to time**. The same is true of the corresponding product specifications. Please check therefore to what extent product descriptions and specifications contained in this publication are still applicable before or when you place an order.

We also **reserve the right to discontinue production and delivery of products**. Consequently, we cannot guarantee that all products named in this publication will always be available. The aforementioned does not apply in the case of individual agreements deviating from the foregoing for customer-specific products.
6. Unless otherwise agreed in individual contracts, **all orders are subject to our General Terms and Conditions of Supply**.
7. **Our manufacturing sites serving the automotive business apply the IATF 16949 standard**. The IATF certifications confirm our compliance with requirements regarding the quality management system in the automotive industry. Referring to customer requirements and customer specific requirements ("CSR") TDK always has and will continue to have the policy of respecting individual agreements. Even if IATF 16949 may appear to support the acceptance of unilateral requirements, we hereby like to emphasize that **only requirements mutually agreed upon can and will be implemented in our Quality Management System**. For clarification purposes we like to point out that obligations from IATF 16949 shall only become legally binding if individually agreed upon.
8. The trade names EPCOS, CeraCharge, CeraDiode, CeraLink, CeraPad, CeraPlas, CSMP, CTVS, DeltaCap, DigiSiMic, ExoCore, FilterCap, FormFit, LeaXield, MiniBlue, MiniCell, MKD, MKK, MotorCap, PCC, PhaseCap, PhaseCube, PhaseMod, PhiCap, PowerHap, PQSine, PQvar, SIFERRIT, SIFI, SIKOREL, SilverCap, SIMDAD, SiMic, SIMID, SineFormer, SIOV, ThermoFuse, WindCap are **trademarks registered or pending** in Europe and in other countries. Further information will be found on the Internet at www.tdk-electronics.tdk.com/trademarks.

Release 2018-10