

16DCT Athlonix™

Ø 16 mm • Precious metal commutation • 5.45 mNm

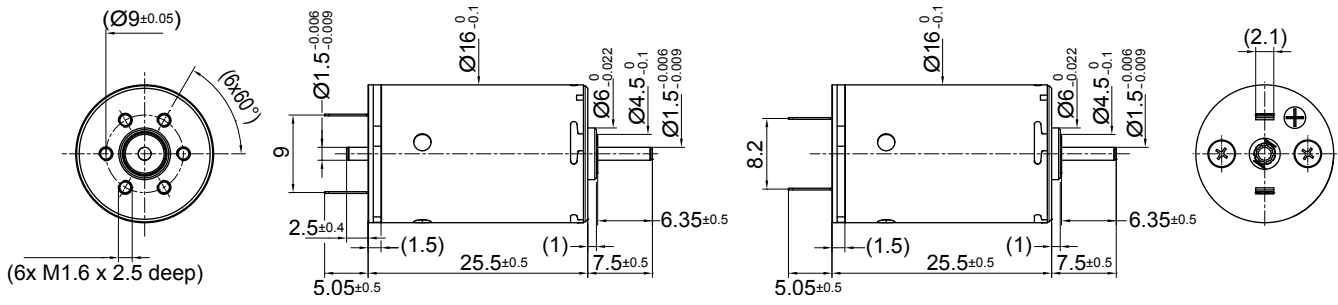

Dimensions in mm.

16DCT 26P2 .... 2

16DCT 26P1 .... 1

Electrical Data	Symbol	16DCT 26P1/P2 .... *					Unit
		219P	219E	213E	211E	207P	
1 Nominal Voltage	V	3	6	9	12	15	Volt
2 No-Load Speed	$n_0$	8081	8600	7970	7968	8599	rpm
3 No-Load Current	$I_0$	28.6	15.2	9.4	7.1	6.1	mA
4 Terminal Resistance	R	0.7	2.3	7.5	13.8	18.6	Ω
5 Output Power	$P_{2max}$	4.2	4.2	4.2	4.1	4.1	W
6 Stall Torque	mNm	16.12 (2.29)	17.13 (2.43)	12.77 (1.81)	12.33 (1.75)	13.21 (1.88)	mNm (oz-in)
7 Efficiency	$h_{max}$	85	85	83	83	83	%
8 Max Continuous Speed	$n_{e max}$	10000	10000	10000	10000	10000	rpm
9 Max Continuous Torque	$M_{e max}$	5.28 (0.75)	5.27 (0.75)	5.36 (0.76)	5.27 (0.75)	5.25 (0.75)	mNm (oz-in)
10 Max Continuous Current	$I_{e max}$	1.53	0.81	0.51	0.38	0.32	A
11 Back-EMF Constant	$k_E$	0.37	0.69	1.12	1.49	1.73	mV/rpm
12 Torque Constant	$k_M$	3.52	6.62	10.70	14.27	16.53	mNm/A
13 Motor Regulation	$R/k^2$	52.47	52.55	65.35	67.66	68.15	10 <sup>3</sup> Nms
14 Friction Torque	$T_F$	0.08 (0.011)	0.08 (0.011)	0.08 (0.011)	0.08 (0.011)	0.08 (0.011)	mNm (oz-in)
15 Mechanical Time Constant	$\tau_m$	7.79	7.80	7.56	7.51	6.63	ms
16 Rotor Inertia	J	1.48	1.48	1.16	1.11	0.97	g-cm <sup>2</sup>

General Data				
17 Thermal Resistance (rotor/body)	$R_{th1}/R_{th2}$	7/35		°C/W
18 Thermal Time Constant (rotor/stator)	$t_{w1}/t_{w2}$	6/380		S
19 Operating Temperature Range:	motor	-30°C to 85°C (-22°F to 185°F)		°C (°F)
	rotor	100°C (212°F)		°C (°F)
20 Shaft Load Max.: (5 mm. from bearing)	-radial	1.5 (5.39)		N (oz)
	-axial	100 (359.6)		N (oz)
21 Shaft Play:	-radial	0.03 (0.0012)		mm (inch)
	-axial	0.15 (0.0059)		mm (inch)
22 Weight	g	23 (0.82)		g (oz)
23 Commutation Segment	-	9		segment

\*Also available with ball bearing

Execution Table

Gearbox	Single Shaft	MR2	M Sense B
R16	1	2	10
B16	3	4	11
BA16	3	4	11

Note:

P1: standard commutation

P2: special commutation for double shaft version

\*Special Ball bearing system available for high radial load requirements

► Motor shaft rotates CW when seen from motor front face when +ve and -ve supply is given to respective terminals.

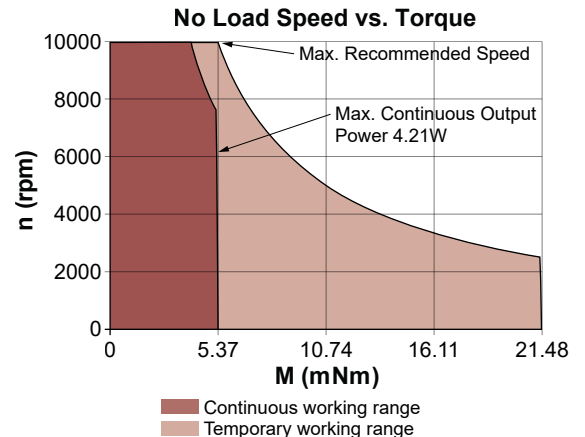

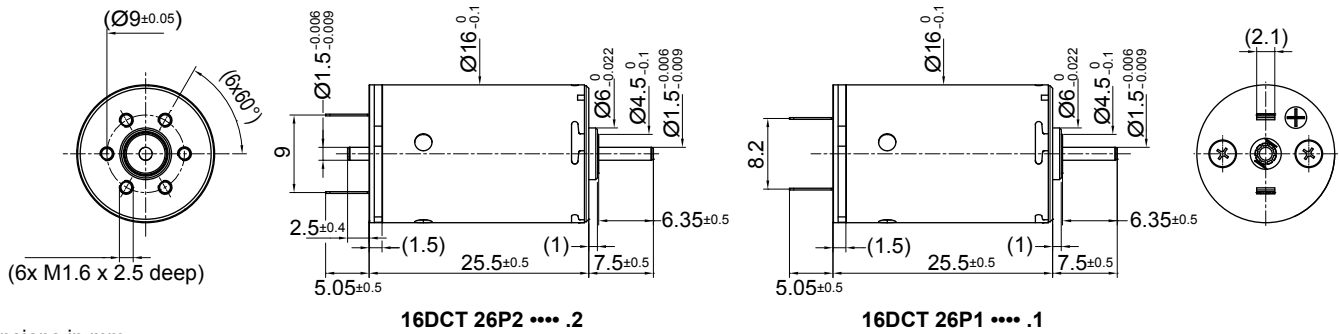

Dimensions in mm.

Electrical Data	Symbol	16DCT 26P1/P2 .... *				Unit
		209E	205P	207E	205E	
1 Nominal Voltage	V	18	24	36	48	Volt
2 No-Load Speed	$n_0$	8261	7993	10079	8380	rpm
3 No-Load Current	$I_0$	4.9	3.5	3.0	1.9	mA
4 Terminal Resistance	R	30.7	51.4	80.9	208.1	$\Omega$
5 Output Power	$P_{2max}$	4.0	4.3	4.1	4.1	W
6 Stall Torque	mNm	11.99 (1.7)	13.2 (1.87)	14.97 (2.13)	12.41 (1.76)	mNm (oz-in)
7 Efficiency	$h_{max}$	83	83	84	83	%
8 Max Continuous Speed	$n_{e max}$	10000	10000	10000	10000	rpm
9 Max Continuous Torque	$M_{e max}$	5.1 (0.73)	5.45 (0.78)	5.16 (0.74)	5.15 (0.73)	mNm (oz-in)
10 Max Continuous Current	$I_{e max}$	0.25	0.19	0.16	0.10	A
11 Back-EMF Constant	$k_E$	2.16	2.98	3.55	5.68	mV/rpm
12 Torque Constant	$k_M$	20.63	28.46	33.88	54.26	mNm/A
13 Motor Regulation	$R/k^2$	72.15	63.00	70.46	70.67	$10^3/Nms$
14 Friction Torque	$T_F$	0.08 (0.011)	0.08 (0.011)	0.08 (0.011)	0.08 (0.011)	mNm (oz-in)
15 Mechanical Time Constant	$\tau_m$	7.48	6.60	7.47	7.46	ms
16 Rotor Inertia	J	1.04	1.04	1.06	1.06	g-cm <sup>2</sup>

General Data				
17 Thermal Resistance (rotor/body)	$R_{th1}/R_{th2}$	7/35		$^{\circ}C/W$
18 Thermal Time Constant (rotor/stator)	$t_{W1}/t_{W2}$	6/380		S
19 Operating Temperature Range:	motor	-30°C to 85°C (-22°F to 185°F) 100°C (212°F)		$^{\circ}C (^{\circ}F)$
	rotor			$^{\circ}C (^{\circ}F)$
20 Shaft Load Max.: (5 mm. from bearing)	-radial	With sleeve bearings 1.5 (5.39)		N (oz)
	-axial	100 (359.6)		N (oz)
	-radial	0.03 (0.0012)		mm (inch)
21 Shaft Play:	-axial	0.15 (0.0059)		mm (inch)
	-axial			mm (inch)
22 Weight	g	23 (0.82)		g (oz)
23 Commutation Segment	-	9		segment

\*Also available with ball bearing

Execution Table

Gearbox	Single Shaft	MR2	M Sense B
R16	1	2	10
B16	3	4	11
BA16	3	4	11

Note:

P1: standard commutation

P2: special commutation for double shaft version

\*Special Ball bearing system available for high radial load requirements

- ▶ Motor shaft rotates CW when seen from motor front face when +ve and -ve supply is given to respective terminals.

