

Material

- Item 1 : Terminal housing:Thermoplastic (UL94V-0),Grey
- Item 2 : Clamp: Brass , Ni plated
- Item 3 : Wire guard solder pin: Brass,Tin plated
- Item 4 : Terminal screw: Steel Zinc plating "-" slot type

Electrical

- Voltage rating: 300V
- Current rating: 10A
- Wire range:
- Solid wire(AWG): 12-22
- Stranded wire(AWG): 12-22
- Torque(Lb-In): 3.5
- Screw: M2.5
- Wire strip length: 6-7mm
- Withstanding Voltage: 1.6KV
- Operating temperature: -40°C to +115°C
- Soldering temperature: 250°C±10°C/5 Sec

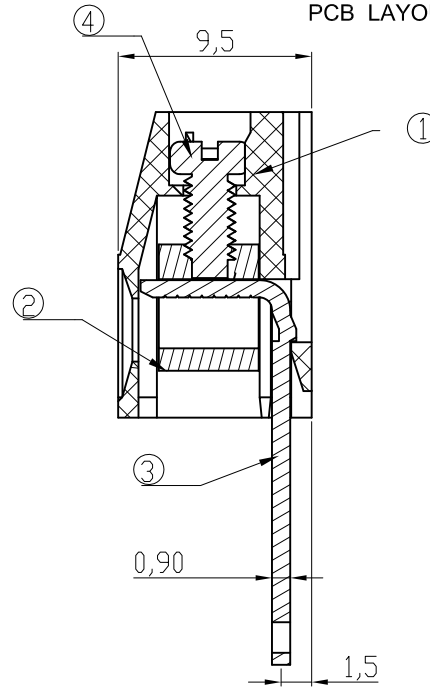
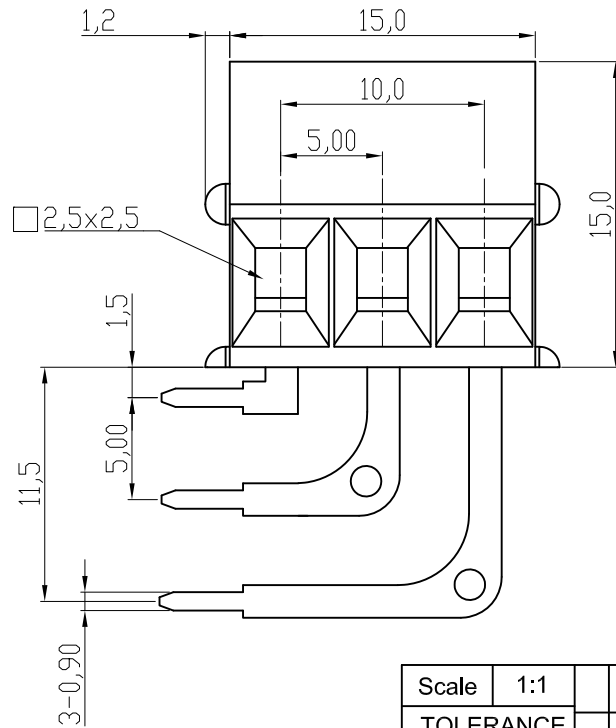

RoHS compliant

Scale	1:1						Date	Name	Customer-No.
TOLERANCE						Drawn	06.12.2006	Alex	
X.	±0.50					Approved	20.04.2010	Hellwig	ASSMANN WSW-No. A-TB500-V303L
X.X	±0.30								Drawing-No.
X.XX	±0.10								ASS 0653A CO
DIM	TOL	①	Update	20.04.2010	Alex				rev00
X.°	±1°	②	Drawn	06.12.2006	Hellwig			Replace	Sheet
Angle	TOL	Id.	Modification	Date	Name				

