

TPA2006D1 Audio Power Amplifier EVM

This document provides an overview of the Texas Instruments (TI) TPA2006D1 audio amplifier evaluation module. It includes a list of EVM features, a brief illustrated description of the module, and a list of EVM specifications.

Contents

| | | |
|---|--|----|
| 1 | Feature Highlights | 2 |
| 2 | Operation | 4 |
| 3 | Related Documentation From Texas Instruments | 11 |

List of Figures

| | | |
|---|---|----|
| 1 | The TI TPA2006D1 Audio Amplifier Evaluation Module..... | 3 |
| 2 | Quick Start Platform Map | 5 |
| 3 | Quick Start Module Map | 7 |
| 4 | TPA2006D1 EVM Connected for Stereo BTL Output | 8 |
| 5 | TPA2006D1 EVM Schematic Diagram | 9 |
| 6 | TPA2006D1 EVM Top Layer | 10 |
| 7 | TPA2006D1 EVM Bottom Layer | 11 |

List of Tables

| | | |
|---|--|---|
| 1 | Typical TI Plug-N-Play Platform Jumper and Switch Settings for the TPA2006D1 EVM . | 4 |
| 2 | Platform Jumper and Switch Settings for the TPA2006D1 EVM..... | 6 |
| 3 | TPA2006D1 EVM Parts List..... | 9 |

1 Feature Highlights

The TI TPA2006D1 audio amplifier evaluation module and the TI plug-n-play audio amplifier evaluation platform include the following features:

- TPA2006D1 Low-Voltage Audio Power Amplifier Evaluation Module
 - 3 mm × 3 mm DRB package
 - Fully differential filter-free Class-D amplifier
 - Single channel, bridge-tied load (BTL)
 - 2.5-V to 5.5-V operation
 - 1.45-W output power into 8 Ω at 5 V, BTL
 - Internal depop and quick start-up circuitry
 - Internal thermal and short-circuit protection
 - Module gain is set at 2 V/V
 - 1.8-V logic level on Shutdown pin; 5-V tolerant
- Quick and Easy Configuration With the TI Plug-n-Play Audio Amplifier Evaluation Platform
 - Evaluation module is designed to simply plug into the platform, automatically making all signal, control, and power connections.
 - Platform provides flexible power options.
 - Jumpers on the platform select power and module control options.
 - Switches on the platform route signals.
 - Platform provides quick and easy audio input and output connections.
- Platform Power Options
 - Onboard 9-V battery
 - External 5-V to 15-V (V_{CC}) supply inputs
 - External regulated V_{DD} supply input
 - Socket for onboard 5-V/3.3-V V_{DD} voltage regulator EVM
 - Onboard overvoltage and reverse polarity power protection
- Platform Audio Input and Output Connections
 - Left and right RCA phono jack inputs
 - Miniature stereo phone jack input
 - Left and right RCA phono jack outputs
 - Left and right compression speaker terminal outputs
 - Miniature stereo headphone jack output

1.1 Description

The TPA2006D1 audio power amplifier evaluation module is a complete, low-power single-channel audio power amplifier. It consists of the TI TPA2006D1 1.45-W low-voltage audio power amplifier IC in a very small DRB package, along with a small number of other parts mounted on a circuit board that is approximately 1.25 in. by 1.125 in (32 mm x 29 mm) (see [Figure 1](#)).

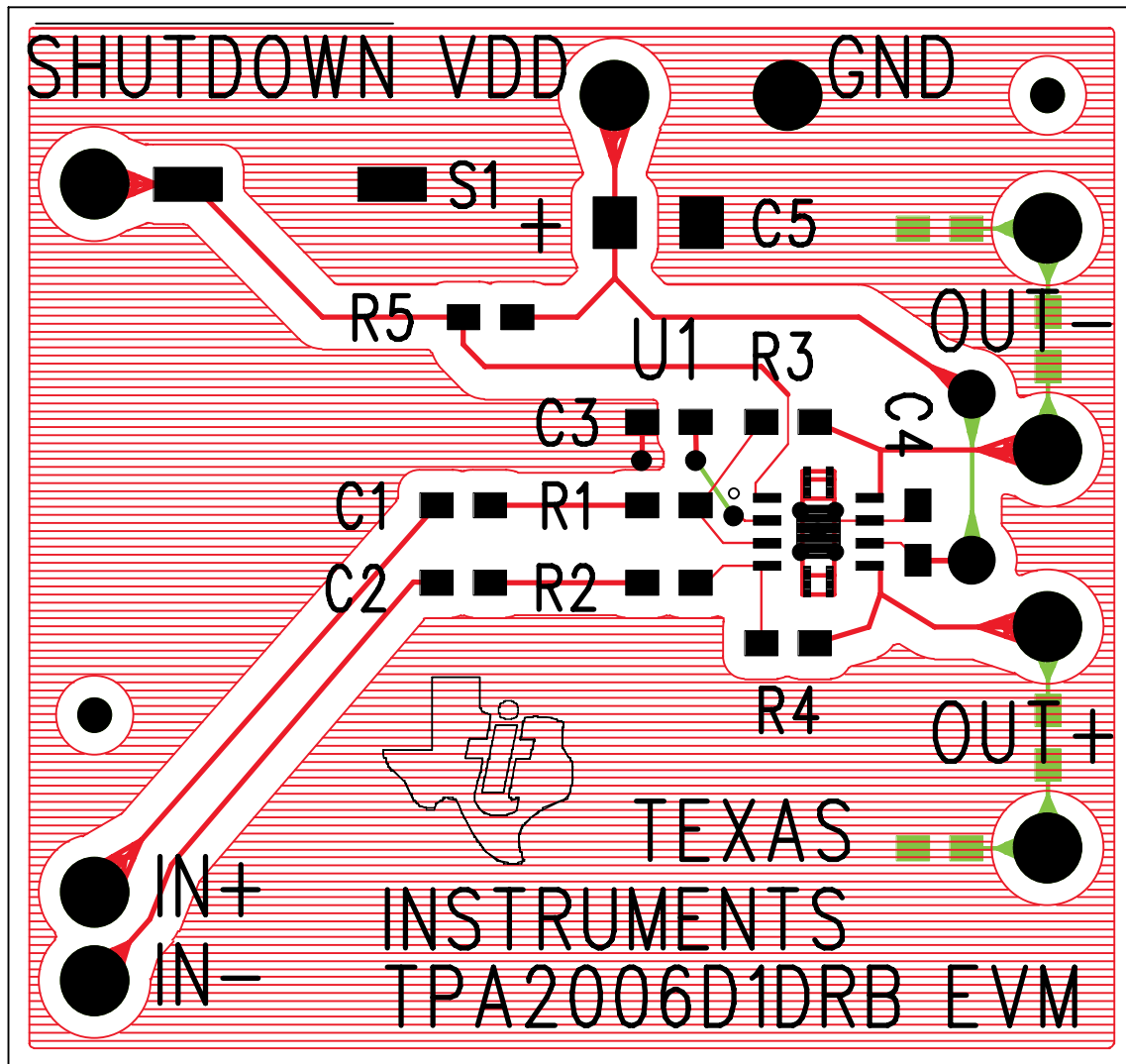

NOTE: Due to the small size of the DRB IC package, the standard part number TPA6002D1DRB is replaced with the code AAOI.

Figure 1. The TI TPA2006D1 Audio Amplifier Evaluation Module

Single in-line header pins are mounted to the underside of the module circuit board. These pins allow the EVM to be plugged into the TI plug-n-play audio amplifier evaluation platform or to be wired directly into existing circuits and equipment when used stand-alone.

The platform, which has room for a pair of TPA2006D1 evaluation modules, is a convenient vehicle for demonstrating TI's audio power amplifier and related evaluation modules. The EVMs simply plug into the platform, which automatically provides power to the modules and connects them to a versatile array of standard audio input and output jacks and connectors. Easy-to-use configuration controls allow the platform and EVMs to quickly model many possible end-equipment configurations.

There is nothing to build, nothing to solder, and nothing but the speakers included with the platform to hook up.

1.2 TPA2006D1 EVM Specifications

| | | VALUE | UNIT |
|----------|---|---------------------|----------|
| V_{DD} | Supply voltage range | 2.5 to 5.5 | V |
| | Power supply current rating required | 500 | mA |
| P_O | Continuous output power, 8 Ω BTL, $V_{DD} = 5$ V | 1.45 | W |
| V_I | Audio input voltage | 0 to V_{DD} , max | V |
| Z_L | Minimum load impedance | 8 | Ω |

2 Operation

Follow the steps in this section to prepare the TPA2006D1 audio amplifier EVM for use. Using the TPA2006D1 EVM with the TI plug-n-play audio amplifier evaluation platform is a quick and easy way to connect power, signal and control inputs, and signal outputs to the EVM, using standard connectors. However, the audio amplifier evaluation module can be used stand-alone by making connections directly to the module pins, and it can be wired directly into existing circuits or equipment.

The platform switch and jumper settings shown in [Table 1](#) are typical for the TPA2006D1 EVM. They cause the TPA2006D1 amplifier IC on the EVM to shut down when a plug is inserted into platform headphone jack J10.

Table 1. Typical TI Plug-N-Play Platform Jumper and Switch Settings for the TPA2006D1 EVM

| EVM | JP6 | JP7 | JP8 | S2 | S3 |
|-----------|------|------------------|-----|--------------------|------------------|
| TPA2006D1 | Mute | X ⁽¹⁾ | Lo | See ⁽²⁾ | X ⁽¹⁾ |

⁽¹⁾ X = Don't care

⁽²⁾ Set S2 to ON when signal conditioning board is installed in U1; set S2 to OFF when no signal conditioning board is installed.

2.1 Precautions

CAUTION

Power Supply Input Polarity and Maximum Voltage

Always ensure that the polarity and voltage of the external power connected to V_{CC} power input connector J1, J2, and/or V_{DD} power input connector J6 are correct. Overvoltage or reverse-polarity power applied to these terminals can open onboard soldered-in fuses and cause other damage to the platform, installed evaluation modules, and/or the power source.

CAUTION

Inserting or Removing EVM Boards

Do not insert or remove EVM boards with power applied—damage to the EVM board, the platform, or both may result.

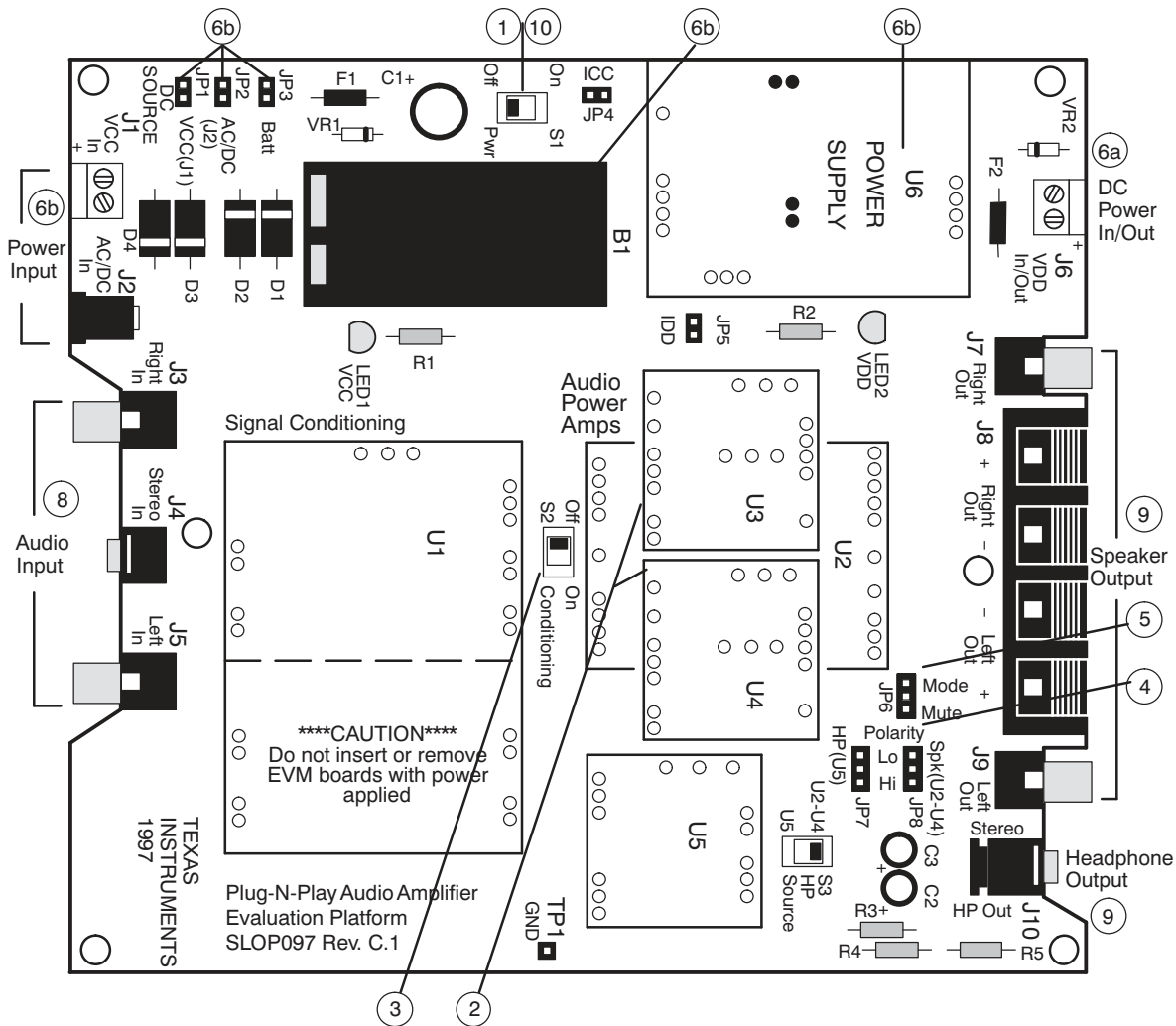

Figure 2. Quick Start Platform Map

2.2 Quick Start List for Platform

Follow these steps when using the TPA2006D1 EVM with the TI plug-n-play audio amplifier evaluation platform (see the platform user's guide, [SLOU011](#), for additional details). Numbered callouts for selected steps are shown in [Figure 2](#).

Platform preparations:

1. Ensure that all external power sources are set to off and that the platform power switch S1 is set to off.
2. Install a TPA2006D1 module in platform sockets U3 and U4 for stereo operation (or a module in either U3 or U4 for single channel operation), taking care to align the module pins correctly.
3. Use switch S2 to select or bypass the signal conditioning EVM (U1).
4. Set control signal polarity jumper JP8 to Lo.
5. Set jumper JP6 to select the mute control input (which causes the TPA2006D1 to shut down if a plug is inserted into platform headphone jack J10).

Table 2. Platform Jumper and Switch Settings for the TPA2006D1 EVM

| EVM | JP6 | JP7 | JP8 | S2 | S3 |
|-----------|------|------------------|-----|--------------------|------------------|
| TPA2006D1 | Mute | X ⁽¹⁾ | Lo | See ⁽²⁾ | X ⁽¹⁾ |

⁽¹⁾ X = Don't care

⁽²⁾ Set S2 to ON when signal conditioning board is installed in U1; set S2 to OFF when no signal conditioning board is installed.

Selecting and connecting the power supply:

- 6a. Connect an external regulated power supply set to a voltage between 2.5 V and 5.5 V to platform V_{DD} power input connector J6, taking care to observe marked polarity,
OR
- 6b. Install a voltage regulator EVM ([SLVP097](#) or equivalent.) in platform socket U6. Install a 9-V battery in B1 or connect a 7 V–12 V power source to a platform V_{CC} power input J1 or J2 and jumper the appropriate power input (see platform user's guide).

Inputs and Outputs Setup:

7. Ensure that signal source level is set to minimum.
8. Connect the audio source to left and right RCA phono jacks J3 and J5 or to stereo miniature phone jack J4.
9. Connect 8 Ω –32 Ω speakers to left and right RCA jacks J7 and J9 or to stripped wire connector J8.

Power-Up Procedure:

10. Verify correct voltage and input polarity and set the external power supply to on. If V_{CC} and an on-board regulator EVM are used to provide V_{DD} , set platform power switch S1 to on. Platform LED2 lights, indicating the presence of V_{DD} , and the evaluation modules installed on the platform begin operation.
11. Adjust the signal source level as needed.

2.3 Quick Start List for Stand-Alone

Follow these steps to use the TPA2006D1 EVM stand-alone or when connecting it into existing circuits or equipment. Connections to the TPA2006D1 module header pins can be made via individual sockets, wire-wrapping, or soldering to the pins, either on the top or the bottom of the module circuit board. Numbered callouts for selected steps are shown in [Figure 3](#).

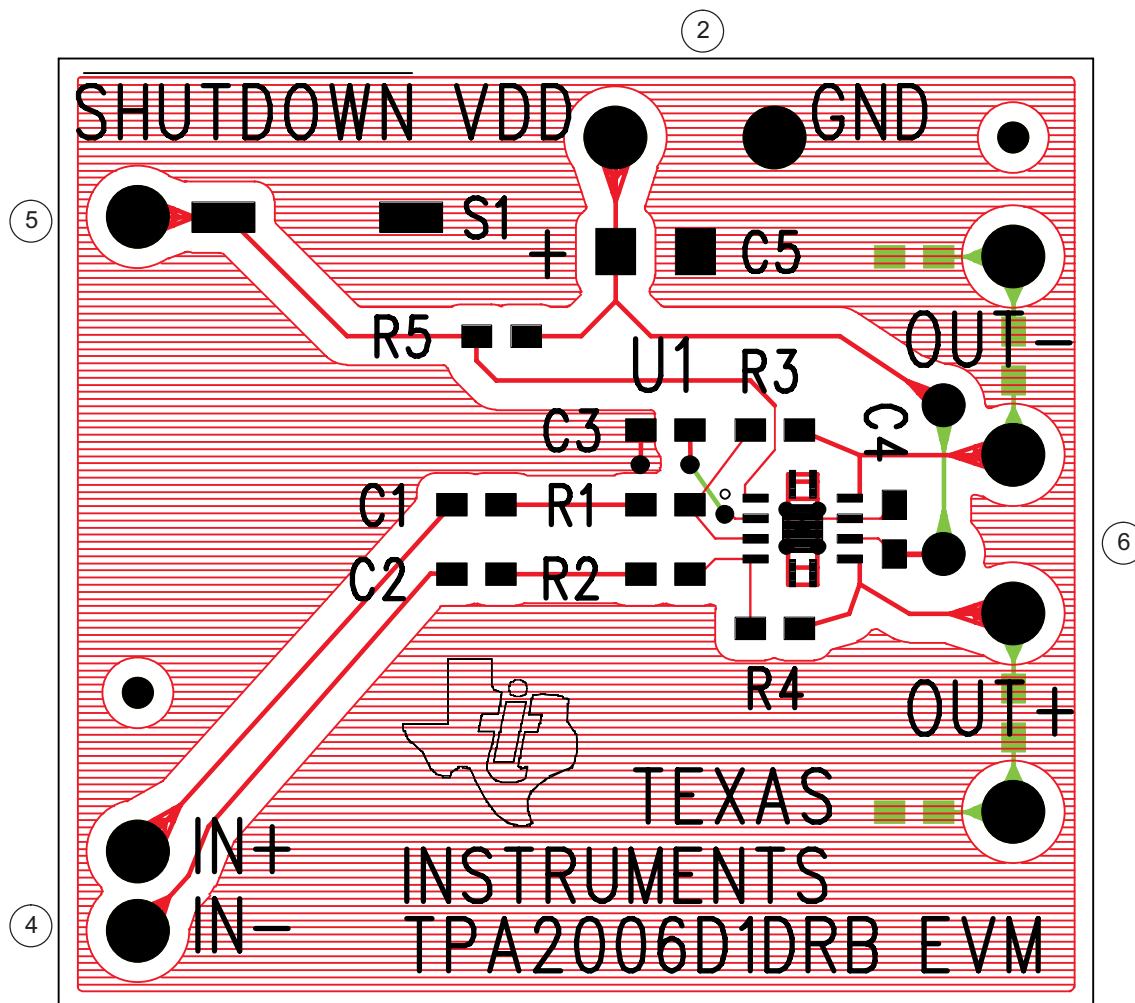

NOTE: Due to the small size of the DRB IC package, the standard part number TPA6002D1DRB is replaced with the code AAOI.

Figure 3. Quick Start Module Map

Power Supply Setup

1. Ensure that all external power sources are set to off.
2. Connect an external regulated power supply set to 5 V to the module V_{DD} and GND pins, taking care to observe marked polarity.

Setting the Inputs and Outputs

3. Ensure that the signal source level is set to minimum.
4. Connect the positive lead from the audio source to module IN+ pin, negative lead to the IN- pin.
5. Connect the SHUTDOWN pin through a normally open switch to GND.
6. Connect an 8Ω – 32Ω speaker to the module OUT+ and OUT- pins.

Power-Up Procedure

7. Verify correct voltage, input polarity; set external power supply to on. The EVM begins operation.
8. Adjust the signal source level as needed.

2.4 References

2.4.1 TPA2006D1 EVM Connected for Stereo BTL Output

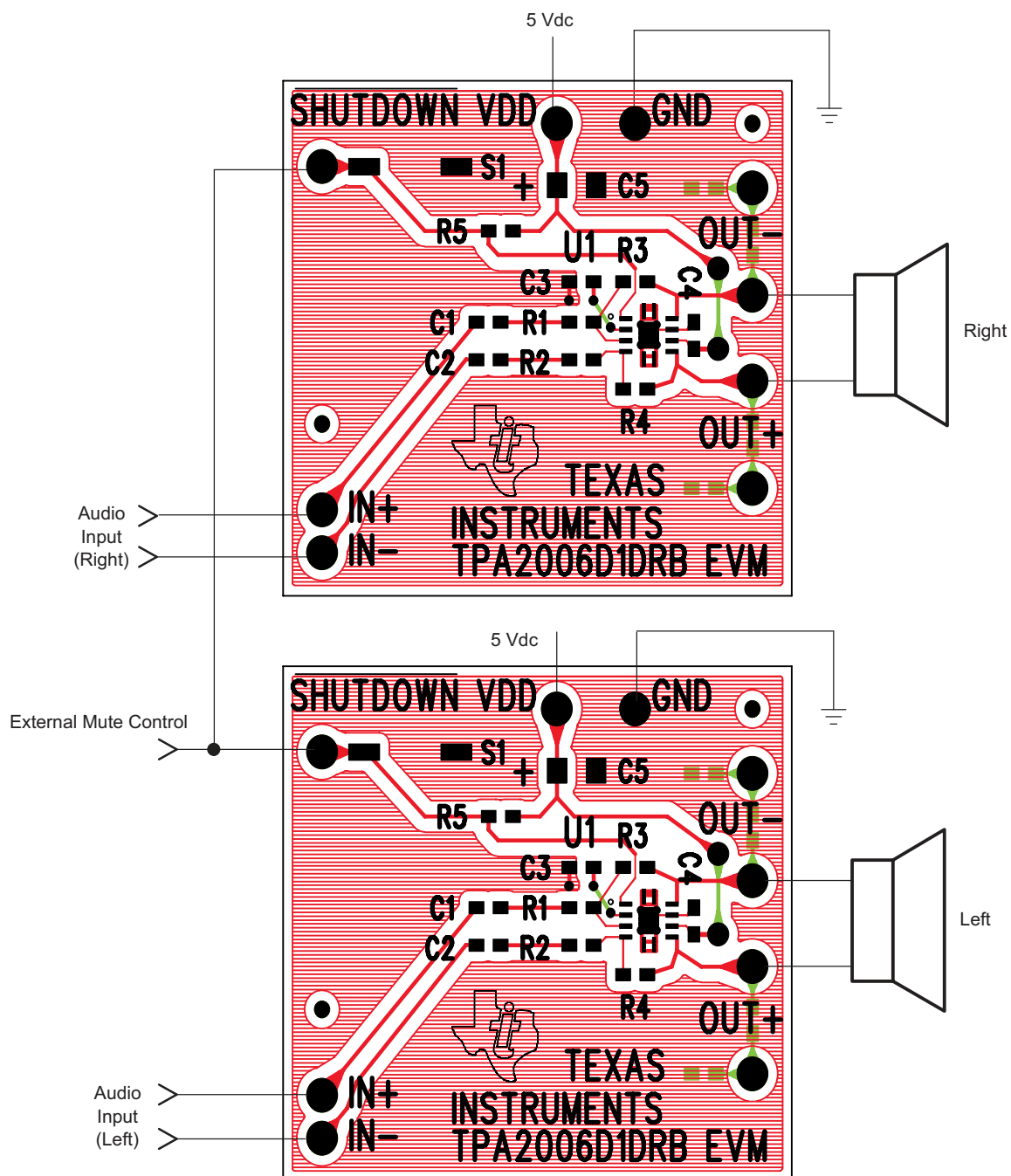

NOTE: Due to the small size of the DRB IC package, the standard part number TPA6002D1DRB is replaced with the code AAOI.

Figure 4. TPA2006D1 EVM Connected for Stereo BTL Output

2.4.2 TPA2006D1 EVM Schematic Diagram

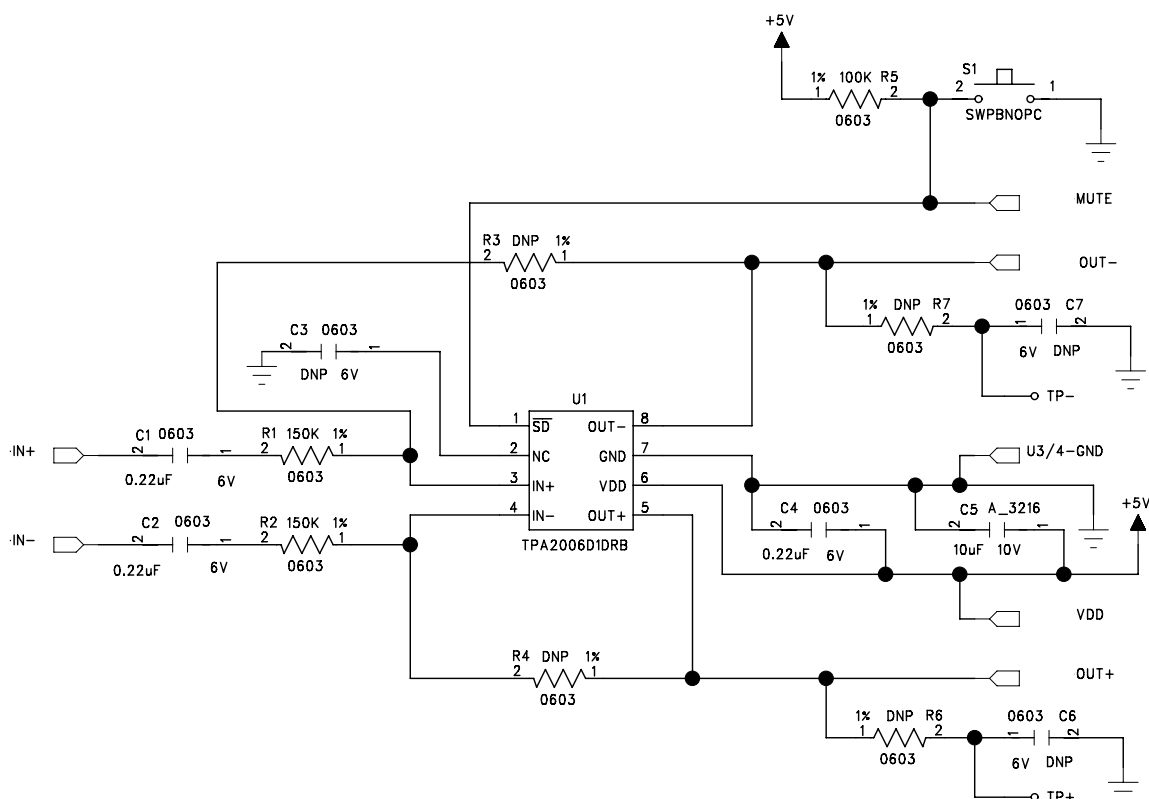

Figure 5. TPA2006D1 EVM Schematic Diagram

2.4.3 TPA2006D1 Audio Power Amplifier Evaluation Module Parts List

Table 3. TPA2006D1 EVM Parts List⁽¹⁾

| Reference ⁽²⁾ | Description | Size | Qty | Manufacturer/ Part Number | Digi-Key Number |
|--------------------------|--|------|-----|---------------------------------|---------------------------|
| C1, C2, C4 | Capacitor, 0.22µF, ±10%, 10V, X7R, nonpolarized SMD ⁽³⁾ | 0603 | 3 | AVX 0603ZC224KAT2A | Digi-Key 478-1243-1-ND |
| C5 | Capacitor, 10µF, 10V, SMD | A | 1 | Kemet T491A106K010AT | Digi-Key 399-3684-1-ND |
| R1, R2 | Resistor, 150kΩ, 1/10 W, 1%, SMD | 0603 | 2 | Panasonic ERJ-3EKF1503V | Digi-Key P150KHTR-ND |
| R5 | Resistor, 100kΩ, 1/16 W, 1%, SMD | 0603 | 1 | Panasonic ERJ-3EKF1003V | Digi-Key P100KHTR-ND |
| S1 | Momentary switch, SMD (low profile) | | 1 | Panasonic EVQ-PJS04K | Digi-Key P8048SCT-ND |
| U1 | Integrated Circuit, TPA2006D1, mono Class-D audio amplifier | | 1 | TI TPA2006DRB ⁽⁴⁾ | |
| | Terminal post headers | | 7 | Sullins PTC36SABN | Digi-Key S1022-36-ND |
| PCB1 | Printed Circuit Board, TPA2006D1DRB EVM | | 1 | | |

(1) All items are SMD except terminal posts.

(2) R3, R4, and C3 pads are available so that TPA6205 can be evaluated using this board.

(3) Substitute only with 10% capacitors.

(4) Due to the small size of the SON DRB package, the standard part number TPA2006D1DRB is replaced with the code AAOI.

2.4.4 TPA2006D1 EVM PCB Layers

The following illustrations depict the TPA2006D1 EVM PCB layers and silkscreen. These drawings are not to scale. Gerber plots can be obtained from www.ti.com.

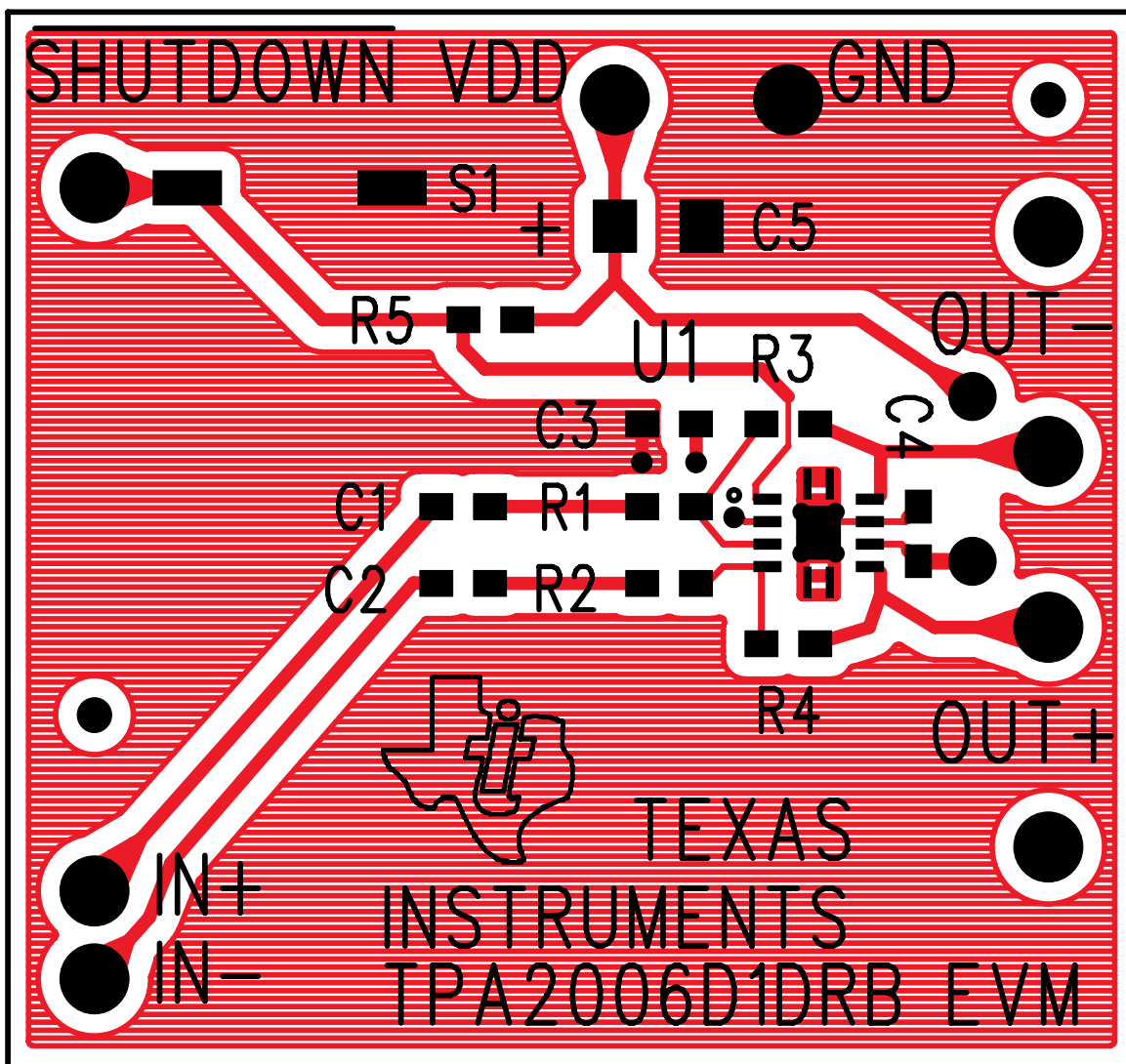

Figure 6. TPA2006D1 EVM Top Layer

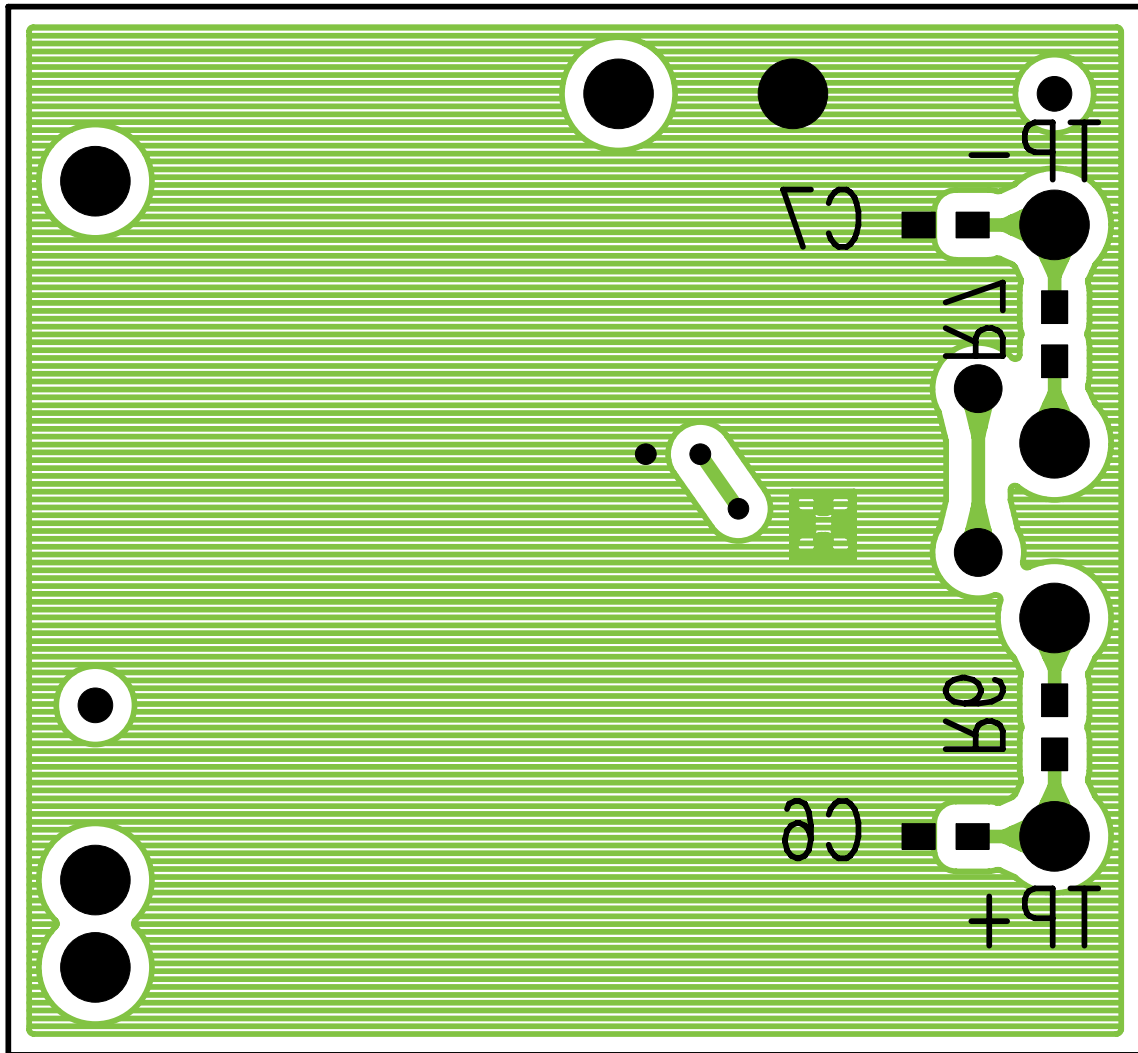

Figure 7. TPA2006D1 EVM Bottom Layer

3 Related Documentation From Texas Instruments

- **TI Plug-N-Play Audio Amplifier Evaluation Platform** ([SLOU011](#)) provides detailed information on the evaluation platform and its use with TI audio evaluation modules.
- **TPA2006D1 1.8-V Control Mono Filter-Free Class-D Audio Power Amplifier** ([SLOS498](#)) This is the data sheet for the TPA2006D1 audio amplifier integrated circuit.

EVALUATION BOARD/KIT IMPORTANT NOTICE

Texas Instruments (TI) provides the enclosed product(s) under the following conditions:

This evaluation board/kit is intended for use for **ENGINEERING DEVELOPMENT, DEMONSTRATION, OR EVALUATION PURPOSES ONLY** and is not considered by TI to be a finished end-product fit for general consumer use. Persons handling the product(s) must have electronics training and observe good engineering practice standards. As such, the goods being provided are not intended to be complete in terms of required design-, marketing-, and/or manufacturing-related protective considerations, including product safety and environmental measures typically found in end products that incorporate such semiconductor components or circuit boards. This evaluation board/kit does not fall within the scope of the European Union directives regarding electromagnetic compatibility, restricted substances (RoHS), recycling (WEEE), FCC, CE or UL, and therefore may not meet the technical requirements of these directives or other related directives.

Should this evaluation board/kit not meet the specifications indicated in the User's Guide, the board/kit may be returned within 30 days from the date of delivery for a full refund. **THE FOREGOING WARRANTY IS THE EXCLUSIVE WARRANTY MADE BY SELLER TO BUYER AND IS IN LIEU OF ALL OTHER WARRANTIES, EXPRESSED, IMPLIED, OR STATUTORY, INCLUDING ANY WARRANTY OF MERCHANTABILITY OR FITNESS FOR ANY PARTICULAR PURPOSE.**

The user assumes all responsibility and liability for proper and safe handling of the goods. Further, the user indemnifies TI from all claims arising from the handling or use of the goods. Due to the open construction of the product, it is the user's responsibility to take any and all appropriate precautions with regard to electrostatic discharge.

EXCEPT TO THE EXTENT OF THE INDEMNITY SET FORTH ABOVE, NEITHER PARTY SHALL BE LIABLE TO THE OTHER FOR ANY INDIRECT, SPECIAL, INCIDENTAL, OR CONSEQUENTIAL DAMAGES.

TI currently deals with a variety of customers for products, and therefore our arrangement with the user **is not exclusive**.

TI assumes **no liability for applications assistance, customer product design, software performance, or infringement of patents or services described herein.**

Please read the User's Guide and, specifically, the Warnings and Restrictions notice in the User's Guide prior to handling the product. This notice contains important safety information about temperatures and voltages. For additional information on TI's environmental and/or safety programs, please contact the TI application engineer or visit www.ti.com/esh.

No license is granted under any patent right or other intellectual property right of TI covering or relating to any machine, process, or combination in which such TI products or services might be or are used.

FCC Warning

This evaluation board/kit is intended for use for **ENGINEERING DEVELOPMENT, DEMONSTRATION, OR EVALUATION PURPOSES ONLY** and is not considered by TI to be a finished end-product fit for general consumer use. It generates, uses, and can radiate radio frequency energy and has not been tested for compliance with the limits of computing devices pursuant to part 15 of FCC rules, which are designed to provide reasonable protection against radio frequency interference. Operation of this equipment in other environments may cause interference with radio communications, in which case the user at his own expense will be required to take whatever measures may be required to correct this interference.

Mailing Address: Texas Instruments, Post Office Box 655303, Dallas, Texas 75265
Copyright © 2006, Texas Instruments Incorporated

EVM WARNINGS AND RESTRICTIONS

It is important to operate this EVM within the input voltage range of 2.5 V to 5.5 V.

Exceeding the specified input range may cause unexpected operation and/or irreversible damage to the EVM. If there are questions concerning the input range, please contact a TI field representative prior to connecting the input power.

Applying loads outside of the specified output range may result in unintended operation and/or possible permanent damage to the EVM. Please consult the EVM User's Guide prior to connecting any load to the EVM output. If there is uncertainty as to the load specification, please contact a TI field representative.

During normal operation, some circuit components may have case temperatures greater than 85°C. The EVM is designed to operate properly with certain components above 85°C as long as the input and output ranges are maintained. These components include but are not limited to linear regulators, switching transistors, pass transistors, and current sense resistors. These types of devices can be identified using the EVM schematic located in the EVM User's Guide. When placing measurement probes near these devices during operation, please be aware that these devices may be very warm to the touch.

Mailing Address: Texas Instruments, Post Office Box 655303, Dallas, Texas 75265
Copyright © 2006, Texas Instruments Incorporated

IMPORTANT NOTICE

Texas Instruments Incorporated and its subsidiaries (TI) reserve the right to make corrections, modifications, enhancements, improvements, and other changes to its products and services at any time and to discontinue any product or service without notice. Customers should obtain the latest relevant information before placing orders and should verify that such information is current and complete. All products are sold subject to TI's terms and conditions of sale supplied at the time of order acknowledgment.

TI warrants performance of its hardware products to the specifications applicable at the time of sale in accordance with TI's standard warranty. Testing and other quality control techniques are used to the extent TI deems necessary to support this warranty. Except where mandated by government requirements, testing of all parameters of each product is not necessarily performed.

TI assumes no liability for applications assistance or customer product design. Customers are responsible for their products and applications using TI components. To minimize the risks associated with customer products and applications, customers should provide adequate design and operating safeguards.

TI does not warrant or represent that any license, either express or implied, is granted under any TI patent right, copyright, mask work right, or other TI intellectual property right relating to any combination, machine, or process in which TI products or services are used. Information published by TI regarding third-party products or services does not constitute a license from TI to use such products or services or a warranty or endorsement thereof. Use of such information may require a license from a third party under the patents or other intellectual property of the third party, or a license from TI under the patents or other intellectual property of TI.

Reproduction of information in TI data books or data sheets is permissible only if reproduction is without alteration and is accompanied by all associated warranties, conditions, limitations, and notices. Reproduction of this information with alteration is an unfair and deceptive business practice. TI is not responsible or liable for such altered documentation.

Resale of TI products or services with statements different from or beyond the parameters stated by TI for that product or service voids all express and any implied warranties for the associated TI product or service and is an unfair and deceptive business practice. TI is not responsible or liable for any such statements.

TI products are not authorized for use in safety-critical applications (such as life support) where a failure of the TI product would reasonably be expected to cause severe personal injury or death, unless officers of the parties have executed an agreement specifically governing such use. Buyers represent that they have all necessary expertise in the safety and regulatory ramifications of their applications, and acknowledge and agree that they are solely responsible for all legal, regulatory and safety-related requirements concerning their products and any use of TI products in such safety-critical applications, notwithstanding any applications-related information or support that may be provided by TI. Further, Buyers must fully indemnify TI and its representatives against any damages arising out of the use of TI products in such safety-critical applications.

TI products are neither designed nor intended for use in military/aerospace applications or environments unless the TI products are specifically designated by TI as military-grade or "enhanced plastic." Only products designated by TI as military-grade meet military specifications. Buyers acknowledge and agree that any such use of TI products which TI has not designated as military-grade is solely at the Buyer's risk, and that they are solely responsible for compliance with all legal and regulatory requirements in connection with such use.

TI products are neither designed nor intended for use in automotive applications or environments unless the specific TI products are designated by TI as compliant with ISO/TS 16949 requirements. Buyers acknowledge and agree that, if they use any non-designated products in automotive applications, TI will not be responsible for any failure to meet such requirements.

Following are URLs where you can obtain information on other Texas Instruments products and application solutions:

| Products | | Applications | |
|-----------------------|--|---------------------|--|
| Amplifiers | amplifier.ti.com | Audio | www.ti.com/audio |
| Data Converters | dataconverter.ti.com | Automotive | www.ti.com/automotive |
| DSP | dsp.ti.com | Broadband | www.ti.com/broadband |
| Interface | interface.ti.com | Digital Control | www.ti.com/digitalcontrol |
| Logic | logic.ti.com | Military | www.ti.com/military |
| Power Mgmt | power.ti.com | Optical Networking | www.ti.com/opticalnetwork |
| Microcontrollers | microcontroller.ti.com | Security | www.ti.com/security |
| RFID | www.ti-rfid.com | Telephony | www.ti.com/telephony |
| Low Power Wireless | www.ti.com/lpw | Video & Imaging | www.ti.com/video |
| | | Wireless | www.ti.com/wireless |

Mailing Address: Texas Instruments, Post Office Box 655303, Dallas, Texas 75265
Copyright © 2007, Texas Instruments Incorporated