

Evaluating the **AD5592R-1** 8-Channel, 12-Bit, Configurable ADC/DAC/GPIO with On-Chip Reference

FEATURES

Full featured evaluation board for the **AD5592R-1**
On-board reference
Various link options
PC control in conjunction with the Analog Devices, Inc.,
EVAL-SDP-CB1Z system demonstration platform (SDP)

EVALUATION KIT CONTENTS

EVAL-AD5592R-1SDZ evaluation board
CD includes
Self-installing evaluation software that allows users to
control the board and exercise all functions of the device
Electronic version of the **EVAL-AD5592R-1SDZ** user guide

ADDITIONAL EQUIPMENT AND SOFTWARE NEEDED

EVAL-SDP-CB1Z system demonstration platform,
includes a USB cable
PC running Windows XP SP2, Windows Vista, or Windows 7
with USB 2.0 port

ONLINE RESOURCES

Documents Needed
AD5592R-1 data sheet
EVAL-AD5592R-1SDZ user guide
Required Software
AD5592R-1 evaluation software (available for download
from the **EVAL-AD5592R-1SDZ** product page)

GENERAL DESCRIPTION

This user guide details the operation of the evaluation board for the **AD5592R-1** 8-channel, 12-bit, configurable ADC/DAC/GPIO with on-chip reference and SPI interface.

The **EVAL-AD5592R-1SDZ** evaluation board is designed to help customers quickly prototype new **AD5592R-1** circuits and reduce design time. The **AD5592R-1** operates from a single 2.7 V to 5.5 V supply and incorporates an internal 2.5 V reference to give an output voltage span of 2.5 V or 5 V. An external reference (a 2.5 V reference is provided on the evaluation board) can also be used to give an output from 0 V to V_{REF} or 0 V to $2 \times V_{REF}$.

Full data on the **AD5592R-1** can be found in the product data sheet, which should be consulted in conjunction with this user guide when using the evaluation board.

The **EVAL-AD5592R-1SDZ** evaluation board interfaces to the USB port of a PC via the **EVAL-SDP-CB1Z** SDP board. Software is supplied with the evaluation board to allow the user to program the **AD5592R-1**.

This evaluation board requires the **EVAL-SDP-CB1Z** SDP-B controller board, which is available for order from the Analog Devices website at www.analog.com.

TYPICAL EVALUATION SETUP

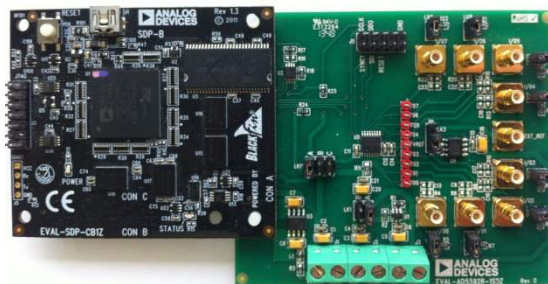

Figure 1.

TABLE OF CONTENTS

Features	1	Link Configuration Options	5
Evaluation Kit Contents.....	1	Setup Conditions.....	5
Additional Equipment and Software Needed.....	1	Evaluation Board Circuitry	6
Online Resources.....	1	How to Use the Software	7
General Description	1	Starting the Software.....	7
Typical Evaluation Setup	1	DAC Tab	8
Revision History	2	ADC Tab.....	8
Getting Started	3	GPIO Tab.....	9
Installing the Software	3	Simple Controls	9
Evaluation Board Setup Procedures.....	3	Evaluation Board Schematics.....	10
Evaluation Board Hardware.....	4	Ordering Information.....	12
Power Supplies	4	Bill of Materials.....	12
Digital Input and Output Signals	4		
Analog Input and Output Signals.....	4		

REVISION HISTORY

10/14—Revision 0: Initial Version

GETTING STARTED

INSTALLING THE SOFTWARE

The evaluation kit for the [AD5592R-1](#) includes self-installing evaluation software on a CD. The evaluation software is compatible with Windows® XP, Windows Vista (32-bit version), and Windows 7 (32-bit and 64-bit versions). The software must be installed before connecting the [EVAL-SDP-CB1Z](#) SDP board to the USB port of the PC to ensure that the SDP board is recognized when it is connected to the PC.

To install the evaluation software, take the following steps:

1. Start the Windows operating system and insert the CD.
2. The installation software should open automatically. If it does not open automatically, run the **setup.exe** file from the CD.
3. After installation is completed, power up the evaluation board as described in the Power Supplies section.
4. Connect the [EVAL-AD5592R-1SDZ](#) evaluation board to the [EVAL-SDP-CB1Z](#) SDP board, and connect the SDP board to the PC using the USB cable included in the evaluation kit.
5. When the software detects the evaluation board, proceed through any dialog boxes that appear to finalize the installation.

EVALUATION BOARD SETUP PROCEDURES

To set up the evaluation board, take the following steps:

1. Connect the [EVAL-AD5592R-1SDZ](#) evaluation board to the [EVAL-SDP-CB1Z](#) SDP board, and connect the USB cable between the SDP board and the PC.
2. Power the SDP board and the evaluation board by connecting 6 V to the J3 connector.

EVALUATION BOARD HARDWARE

POWER SUPPLIES

To use the EVAL-AD5592R-1SDZ evaluation board with the EVAL-SDP-CB1Z SDP board, a 6 V power supply is required, which is connected to Connector J3. The evaluation board can also be used without the SDP board, in which case the J2 is the power supply input for the V_{DD} supply. A separate V_{LOGIC} supply can be connected to J1. LK 11 selects the source for the AD5592R-1 V_{LOGIC} supply.

Both the AGND and DGND inputs are provided on the board. The AGND and DGND planes are connected at one location close to the AD5592R-1. It is recommended that AGND and DGND not be connected elsewhere in the system to avoid ground loop problems.

All supplies are decoupled to ground with 10 μ F tantalum and 0.1 μ F ceramic capacitors.

Table 1. Power Supply Connectors

Connector Number	Voltage
J1	External V_{LOGIC} supply
J2	Analog power supply, V_{DD}
J3	6 V board positive power supply

DIGITAL INPUT AND OUTPUT SIGNALS

When the SDP board is used to control the evaluation board, the digital input signals are applied to Connector J4. When the SDP board is not used, digital signals are applied to the 10-way header, J5.

ANALOG INPUT AND OUTPUT SIGNALS

The I/Ox pins of the AD5592R-1 are available on the SMB connectors, I/O0 to I/O7. These connectors are analog inputs or outputs, depending on whether the I/Ox pins are configured as ADCs or DACs, respectively. I/O0 to I/O7 are digital inputs or outputs if the I/Ox pins are configured as GPIOs.

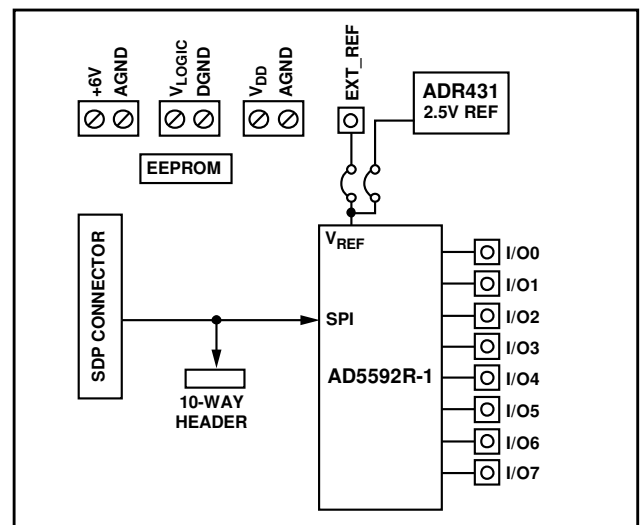

Figure 2. Evaluation Board Block Diagram

LINK CONFIGURATION OPTIONS

A number of link options are incorporated in the [EVAL-AD5592R-1SDZ](#) evaluation board and must be set for the required operating conditions before using the board. The functions of these link options are described in Table 2.

SETUP CONDITIONS

Before applying power and signals to the evaluation board, ensure that all link positions are as required by the operating mode. There are two modes in which to operate the evaluation

board. The evaluation board can be operated in SDP controlled mode to be used with the SDP board, or the evaluation board can be used in standalone mode.

Table 2 shows the default positions in which the links are set when the evaluation board is packaged. When the evaluation board is shipped, it is set up to be operated with the [EVAL-SDP-CB1Z](#) board in SDP controlled mode.

Table 2. Link Functions

Link Number	Option	Default Position
LK1	This link selects the V_{DD} source for the AD5592R-1 . Position A selects the internal voltage source (5V_VDD) from the ADP3331 . Position B selects an external supply voltage (EXT_VDD).	A
LK2, LK4, LK5 to LK9, LK20	These links connect 85 k Ω pull-down resistors from the I/Ox pins to AGND. When the link is removed, the level of the associated pin is determined by the configuration of the AD5592R-1 .	IN
LK3	This link selects the reference source for the AD5592R-1 . Position A selects the on-board 2.5 V reference as the reference source. Position B selects an off board voltage reference via the EXT_REF connector. Select this option if the internal reference is to be used.	A
LK11	This link selects the source of the V_{LOGIC} supply for the AD5592R-1 . Position A selects the 3.3 V supply from the SDP board. Position B selects the V_{LOGIC} supply from Connector J1. Position C selects the V_{DD} supply determined by LK1.	A

EVALUATION BOARD CIRCUITRY

The [EVAL-AD5592R-1SDZ](#) evaluation board allows the function and performance of the [AD5592R-1](#) to be easily tested. The evaluation board contains two voltage regulators, which generate the analog and digital power supplies and which also power the SDP board, if it is connected. The two regulators are powered via a 6 V supply attached to Connector J3. Alternatively, a separate supply can be attached via Connector J2. An optional V_{LOGIC} supply can be connected to J1, if required.

The [AD5592R-1](#) is typically controlled by the SDP board, which is attached to Connector J4. The SDP board allows the evaluation

software (provided with the evaluation kit) to configure the [AD5592R-1](#) and to write and read data to and from the [AD5592R-1](#).

When the SDP board is not required, the control signals can be applied to the [AD5592R-1](#) by connecting them to the relevant pins on Connector J5.

In addition to the [AD5592R-1](#) on-chip reference, an external 2.5 V reference is also provided and can be connected to the [AD5592R-1](#) reference input/output pin (V_{REF}) using LK3.

HOW TO USE THE SOFTWARE

STARTING THE SOFTWARE

To run the evaluation software, take the following steps:

1. Connect the [EVAL-AD5592R-1SDZ](#) evaluation board to the [EVAL-SDP-CB1Z](#) SDP board, and connect the USB cable between the SDP board and the PC.
2. Power the SDP board and the evaluation board by connecting 6 V to the J3 connector.
3. Click **Start > All Programs > Analog Devices > AD5592R-1 > AD5592R-1 Evaluation Software**. When the software connects to the evaluation board, the message shown in Figure 3 displays.



Figure 3. Connection Message

If the SDP board is not connected to the USB port when the software is launched, a connectivity error displays (see Figure 4). Connect the evaluation board to the USB port of the PC, wait a few seconds, click **Rescan**, and follow the instructions.

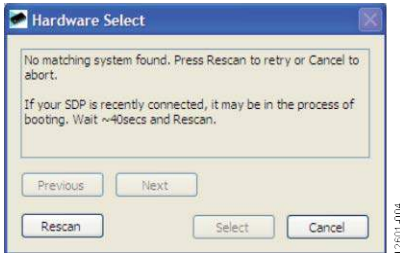

Figure 4. Connectivity Error

Alternatively, the evaluation software can be used without an evaluation board. The software runs in simulation mode, displaying expected outputs based on the input data. When the software runs, the user is first prompted to configure the [AD5592R-1](#) I/Ox pins, as shown in Figure 5. The main window of the [AD5592R-1](#) evaluation software then opens, as shown in Figure 6. The user can click on the block diagram to access the DAC, ADC, and GPIO functions, as well as other options such as enabling the internal reference.

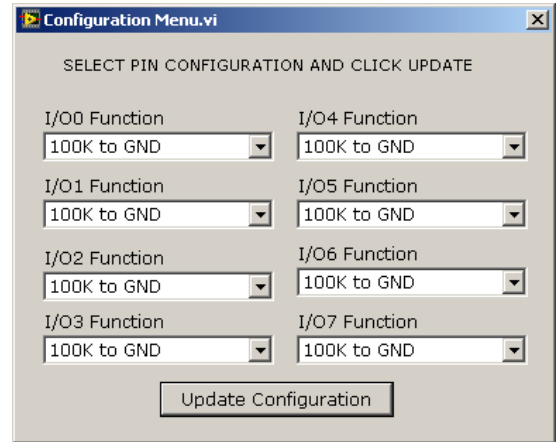

Figure 5. Configuration Menu

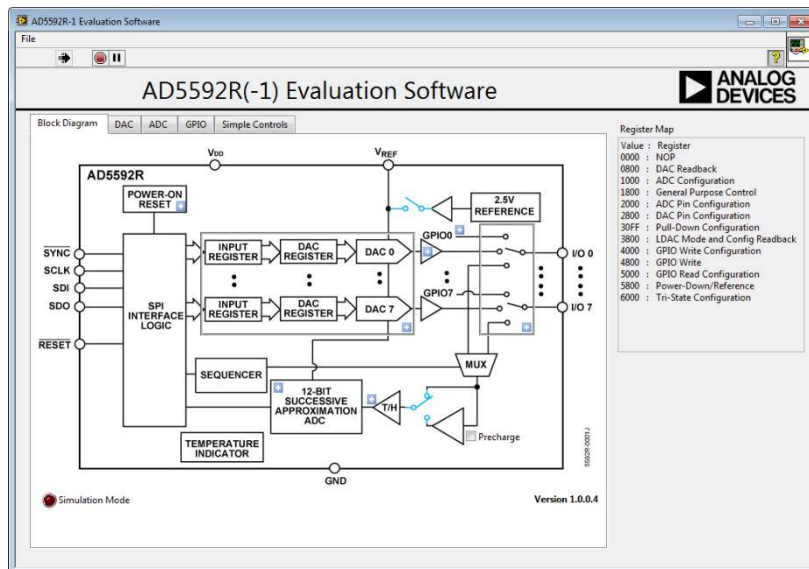

Figure 6. Main Window, **Block Diagram** Tab

DAC TAB

The DAC tab gives the user access to the DAC functions. Each DAC has its own numeric control where a value to be loaded to the appropriate DAC. Clicking **Update DAC Registers** loads the data appropriately as determined by the setting of the **LDAC Mode** control box.

ADC TAB

The ADC tab allows the user to select ADC channels on which to perform conversions. Select **REPEAT SEQUENCE** to take multiple samples. The user can select the number of samples per channel and the sample frequency. Clicking **Take Samples** programs the **AD5592R-1** for the desired sequence and takes the appropriate number of samples. The data collected from the **AD5592R-1** is split into separate channels and displayed on the graph as a voltage. The user has the option to save the data to a comma delimited spreadsheet file.

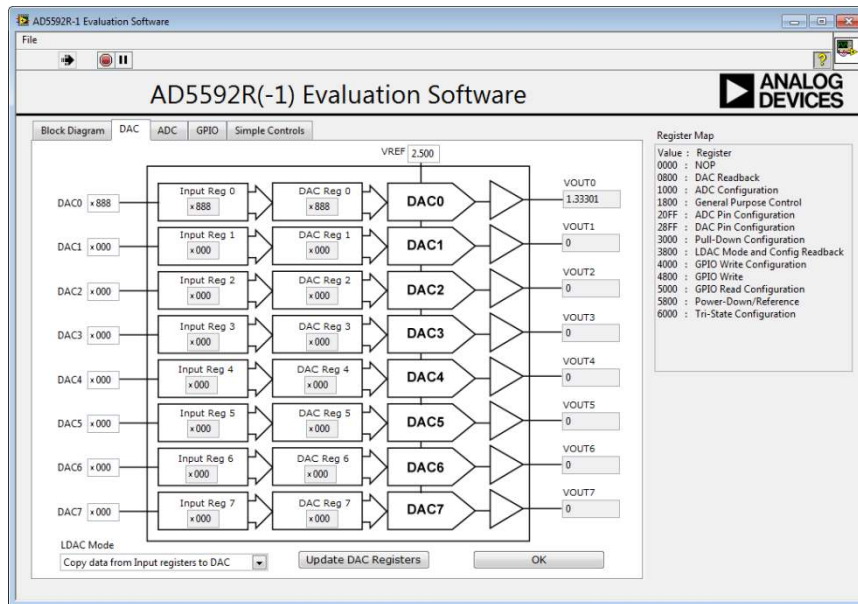

Figure 7. DAC Tab

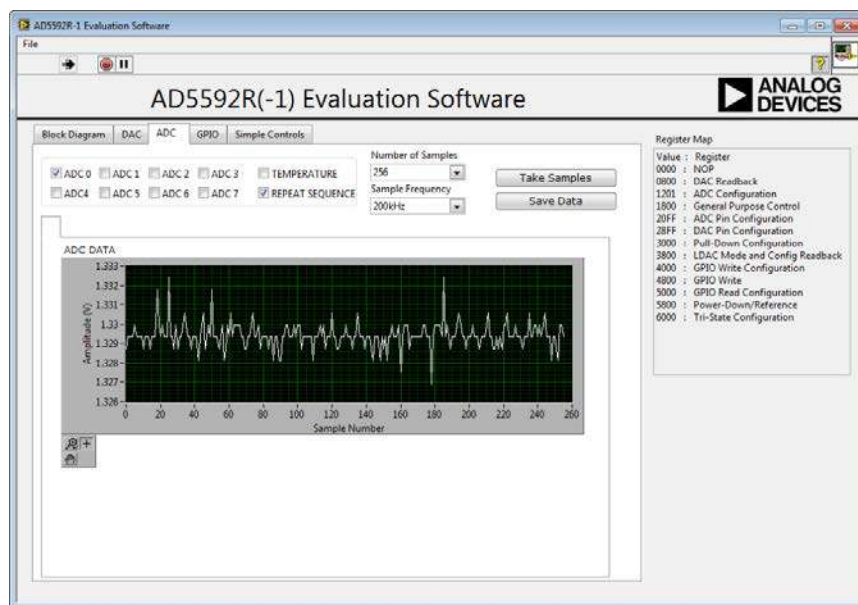

Figure 8. ADC Tab

GPIO TAB

The **GPIO** tab allows the user to set the output levels for pins set as general-purpose outputs and to read the levels of pins set as general-purpose inputs as shown in Figure 9.

SIMPLE CONTROLS

The **Simple Controls** tab allows the user to enter 16-bit values directly into the **Write Array** control. These values can then be

written to the [AD5592R-1](#) by clicking the **Write and Read** button. Data that appears on the SDO pin of the [AD5592R-1](#) is shown in the **Read Array** control. The data displayed in the **Read Array** control is invalid if it is not part of a read operation from the [AD5592R-1](#). Any commands sent to the [AD5592R-1](#) that change the configuration of the [AD5592R-1](#) are not reflected in the other tabs. The **Simple Controls** tab is shown in Figure 10.

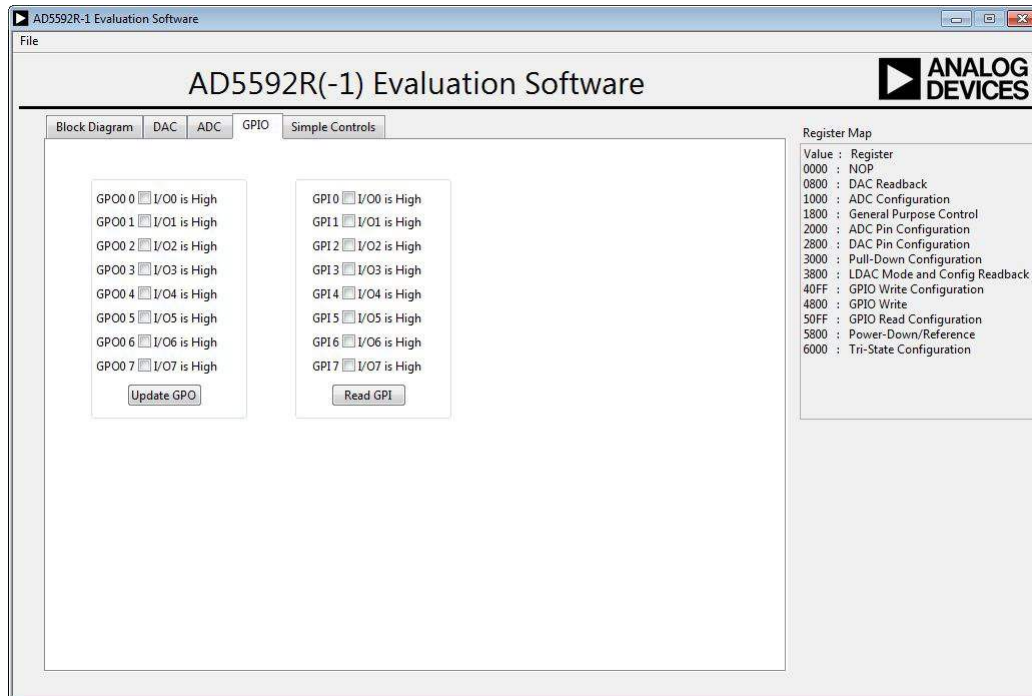

Figure 9. **GPIO** Tab

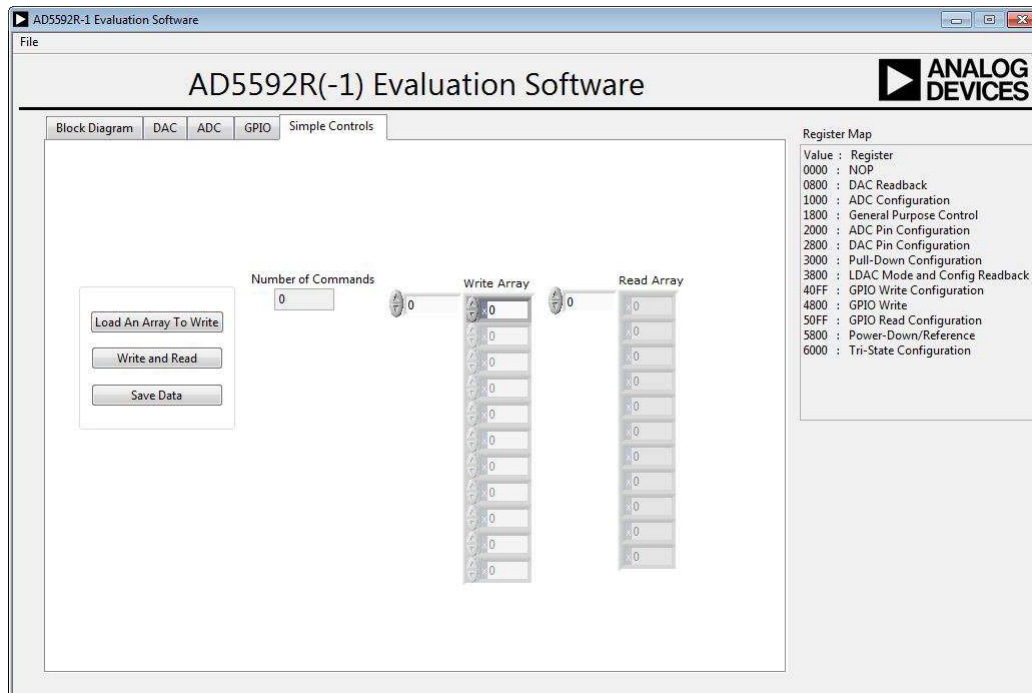

Figure 10. **Simple Controls** Tab

EVALUATION BOARD SCHEMATICS

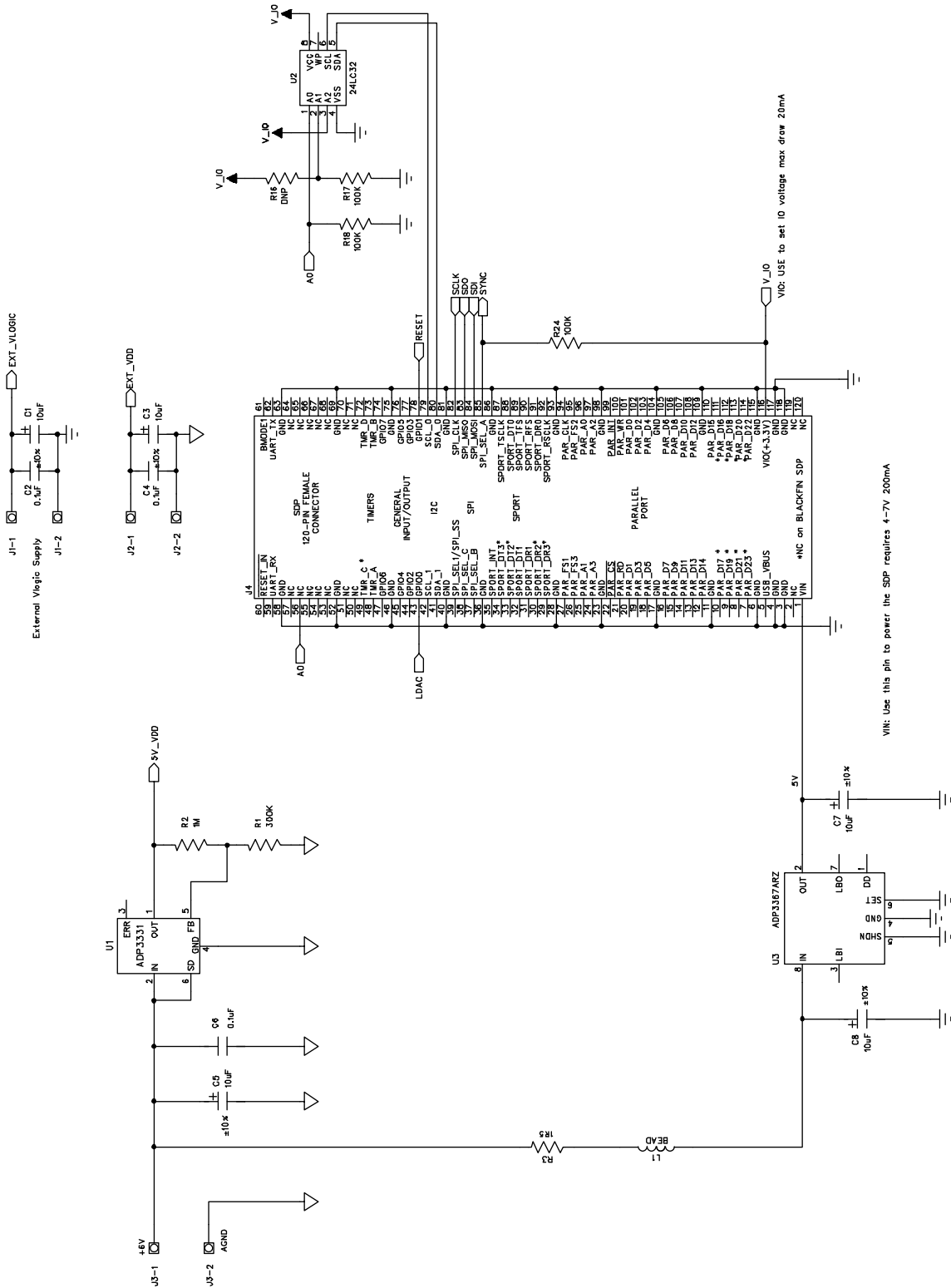
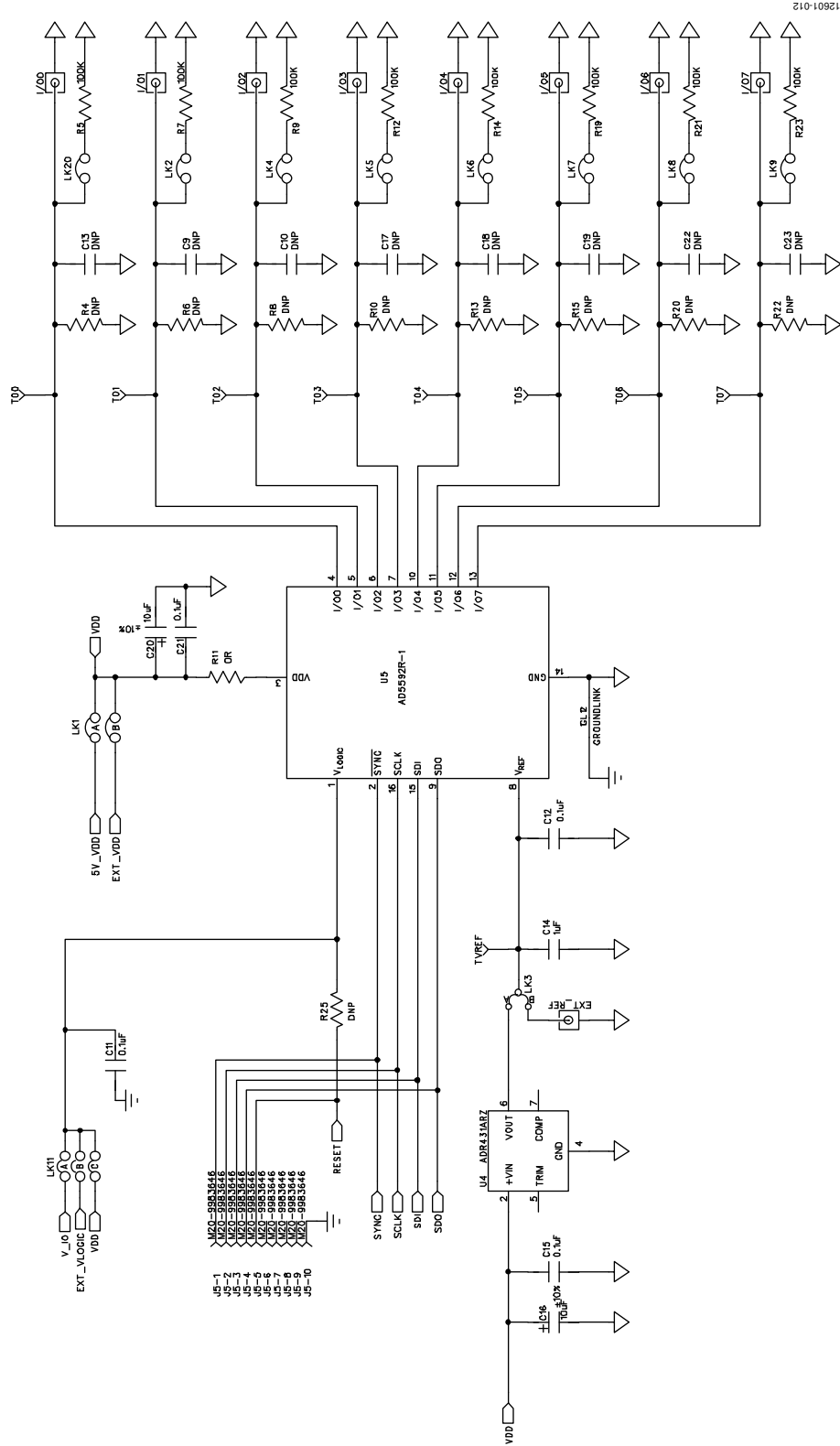

Figure 11. EVAL-AD592R-1SDZ Schematic, Page 1 of 2



12601-012

Figure 12. EVAL-AD5592R-1SDZ Schematic, Page 2 of 2

ORDERING INFORMATION

BILL OF MATERIALS

Table 3.

Qty	Reference Designator	Description	Supplier/Part Number ¹
1	C1	Noninserted through-hole capacitor location	Do not insert
8	C3 to C6, C22, C24, C27, C29	Capacitor, 100 nF, 50 V, 0603	FEC 8820023
9	C15 to C18, C23, C25, C26, C28, C30	Capacitor, Case A, 10 μ F, 10 V	FEC 197-130
1	J1	120-way female connector, 0.6 mm pitch	FEC 1324660 or Digi-Key H1219-ND
1	J2	20-pin (2 \times 10) header, 0.1" pitch	FEC 1022242
1	J3	7-pin (1 \times 7) header, 0.1" pitch	FEC 1022257
3	J4 to J6	50 Ω straight SMB jack	FEC 1111349
3	J7 to J9	2-pin terminal block (5 mm pitch)	FEC 151789
1	L1	Ferrite bead	Digi-Key 490-1024-1-ND
5	LK1 to LK5	2-pin SIL header, 0.1" pitch, red jumper	FEC 1022247 and FEC 150-411
6	LK6 to LK11	3-pin SIL header, 0.1" pitch, red jumper	FEC 1022248 and FEC 150411
4	R1 to R3, R13	SMD resistor 0603	FEC 933-0399
1	R4	Noninserted through-hole resistor location	Do not insert
1	R5	Resistor, 1.5 Ω , 5%, 0.063 W, 0603	FEC 9331832
1	R6	Resistor, 1 M Ω , 1%, 0.063 W, 0603	Digi-Key RMCF1/161MFRCT-ND
1	R7	SMD resistor 0603	Digi-Key 541-300KHCT-ND
3	R8, R14, R15	SMD resistor 0603	Do not insert
2	R9, R10	SMD resistor	FEC 9330402
2	R11, R12	SMD resistor 0603	FEC 933-1662
1	R25	Not populated	
10	TP1 to TP10	Black test point	FEC 8731128
1	U1	8-channel, 12-bit, configurable ADC/DAC	AD5592RBCPZ-1
1	U2	2.5 V reference	ADR431ARZ
1	U3	Adjustable LDO regulator	ADP3331ARTZ
1	U4	32k I ² C serial EEPROM	FEC 1331330
1	U5	5 V fixed, adjustable voltage regulator	ADP3367ARZ
2	Screw1, Screw2	Screw, cheese, nylon, M3X10, PK100	FEC 7070597
2	Nut1, Nut2	Nut/washer, nylon, M3, PK100	FEC 7061857

¹ FEC is Farnell Electronics Components.

NOTES



ESD Caution

ESD (electrostatic discharge) sensitive device. Charged devices and circuit boards can discharge without detection. Although this product features patented or proprietary protection circuitry, damage may occur on devices subjected to high energy ESD. Therefore, proper ESD precautions should be taken to avoid performance degradation or loss of functionality.

Legal Terms and Conditions

By using the evaluation board discussed herein (together with any tools, components documentation or support materials, the "Evaluation Board"), you are agreeing to be bound by the terms and conditions set forth below ("Agreement") unless you have purchased the Evaluation Board, in which case the Analog Devices Standard Terms and Conditions of Sale shall govern. Do not use the Evaluation Board until you have read and agreed to the Agreement. Your use of the Evaluation Board shall signify your acceptance of the Agreement. This Agreement is made by and between you ("Customer") and Analog Devices, Inc. ("ADI"), with its principal place of business at One Technology Way, Norwood, MA 02062, USA. Subject to the terms and conditions of the Agreement, ADI hereby grants to Customer a free, limited, personal, temporary, non-exclusive, non-sublicensable, non-transferable license to use the Evaluation Board FOR EVALUATION PURPOSES ONLY. Customer understands and agrees that the Evaluation Board is provided for the sole and exclusive purpose referenced above, and agrees not to use the Evaluation Board for any other purpose. Furthermore, the license granted is expressly made subject to the following additional limitations: Customer shall not (i) rent, lease, display, sell, transfer, assign, sublicense, or distribute the Evaluation Board; and (ii) permit any Third Party to access the Evaluation Board. As used herein, the term "Third Party" includes any entity other than ADI, Customer, their employees, affiliates and in-house consultants. The Evaluation Board is NOT sold to Customer; all rights not expressly granted herein, including ownership of the Evaluation Board, are reserved by ADI. CONFIDENTIALITY. This Agreement and the Evaluation Board shall all be considered the confidential and proprietary information of ADI. Customer may not disclose or transfer any portion of the Evaluation Board to any other party for any reason. Upon discontinuation of use of the Evaluation Board or termination of this Agreement, Customer agrees to promptly return the Evaluation Board to ADI. ADDITIONAL RESTRICTIONS. Customer may not disassemble, decompile or reverse engineer chips on the Evaluation Board. Customer shall inform ADI of any occurred damages or any modifications or alterations it makes to the Evaluation Board, including but not limited to soldering or any other activity that affects the material content of the Evaluation Board. Modifications to the Evaluation Board must comply with applicable law, including but not limited to the RoHS Directive. TERMINATION. ADI may terminate this Agreement at any time upon giving written notice to Customer. Customer agrees to return to ADI the Evaluation Board at that time. LIMITATION OF LIABILITY. THE EVALUATION BOARD PROVIDED HEREUNDER IS PROVIDED "AS IS" AND ADI MAKES NO WARRANTIES OR REPRESENTATIONS OF ANY KIND WITH RESPECT TO IT. ADI SPECIFICALLY DISCLAIMS ANY REPRESENTATIONS, ENDORSEMENTS, GUARANTEES, OR WARRANTIES, EXPRESS OR IMPLIED, RELATED TO THE EVALUATION BOARD INCLUDING, BUT NOT LIMITED TO, THE IMPLIED WARRANTY OF MERCHANTABILITY, TITLE, FITNESS FOR A PARTICULAR PURPOSE OR NON-INFRINGEMENT OF INTELLECTUAL PROPERTY RIGHTS. IN NO EVENT WILL ADI AND ITS LICENSORS BE LIABLE FOR ANY INCIDENTAL, SPECIAL, INDIRECT, OR CONSEQUENTIAL DAMAGES RESULTING FROM CUSTOMER'S POSSESSION OR USE OF THE EVALUATION BOARD, INCLUDING BUT NOT LIMITED TO LOST PROFITS, DELAY COSTS, LABOR COSTS OR LOSS OF GOODWILL. ADI'S TOTAL LIABILITY FROM ANY AND ALL CAUSES SHALL BE LIMITED TO THE AMOUNT OF ONE HUNDRED US DOLLARS (\$100.00). EXPORT. Customer agrees that it will not directly or indirectly export the Evaluation Board to another country, and that it will comply with all applicable United States federal laws and regulations relating to exports. GOVERNING LAW. This Agreement shall be governed by and construed in accordance with the substantive laws of the Commonwealth of Massachusetts (excluding conflict of law rules). Any legal action regarding this Agreement will be heard in the state or federal courts having jurisdiction in Suffolk County, Massachusetts, and Customer hereby submits to the personal jurisdiction and venue of such courts. The United Nations Convention on Contracts for the International Sale of Goods shall not apply to this Agreement and is expressly disclaimed.

©2014 Analog Devices, Inc. All rights reserved. Trademarks and registered trademarks are the property of their respective owners.
UG12601-0-10/14(0)



www.analog.com