

DESCRIPTION

Demonstration circuit 551 is a complete constant-current/constant-voltage battery charger designed to charge one Lithium-Ion cell. Programmed for 3A charge current, this board features a 500kHz step down switching regulator controller driving a P-channel MOSFET. A fixed 3 hour timer is included for charge termination in addition to a charge status LED to indicate a near-full-charge condition and a thermistor connection for battery temperature charge qualification. Because of the heat generated by the circuit, the thermistor must not be mounted

on this board. A 10k resistor (R3) is used instead of a thermistor on this board.

The LTC[®]4002 on this board is in a tiny 3 X 3 mm 10 pin DFN package. All surface mount components are used to minimize board space and height with the circuitry occupying approximately 0.5 square inches of board space although additional pc-board copper is needed for heat dissipation.

Design files for this circuit board are available. Call the LTC factory.

LTC is a registered trademark of Linear Technology Corporation

Other Features include:

- Preset float voltages of 4.2V \pm 1%
- 3A Constant Current (can be programmed for other charge currents)
- 3 Hour charge termination timer
- NTC Thermistor input for sensing battery temperature
- Undervoltage Lockout
- Manual Shutdown
- Low battery drain current when input supply is removed
- C/10 Trickle charge for deeply discharged batteries
- Auto recharge when battery voltage drops below preset threshold
- C/5 Charge LED indicator (CHRG)

QUICK START GUIDE FOR DEMONSTRATION CIRCUIT 551 LITHIUM-ION BATTERY CHARGER WITH CHARGE TERMINATION

Typical Demo Board Specifications

Input Voltage Range (V_{IN})	5.2V to 24V
Charge Voltage (V_{BAT}) (constant voltage mode)	4.2V \pm 1%
Charge Current I_{BAT} (constant current mode)	3A \pm 8%
Charge Current I_{BAT} (trickle current mode)	350mA \pm 20%
C/5 CHRГ LED Threshold Level	750mA \pm 25%
Trickle Charge Threshold Voltage	2.9V
Battery Drain Current with V_{IN} Removed	<20 μ A *

* Main cause of drain current is due to Schottky diode leakage current.

Figure 1. Test Setup

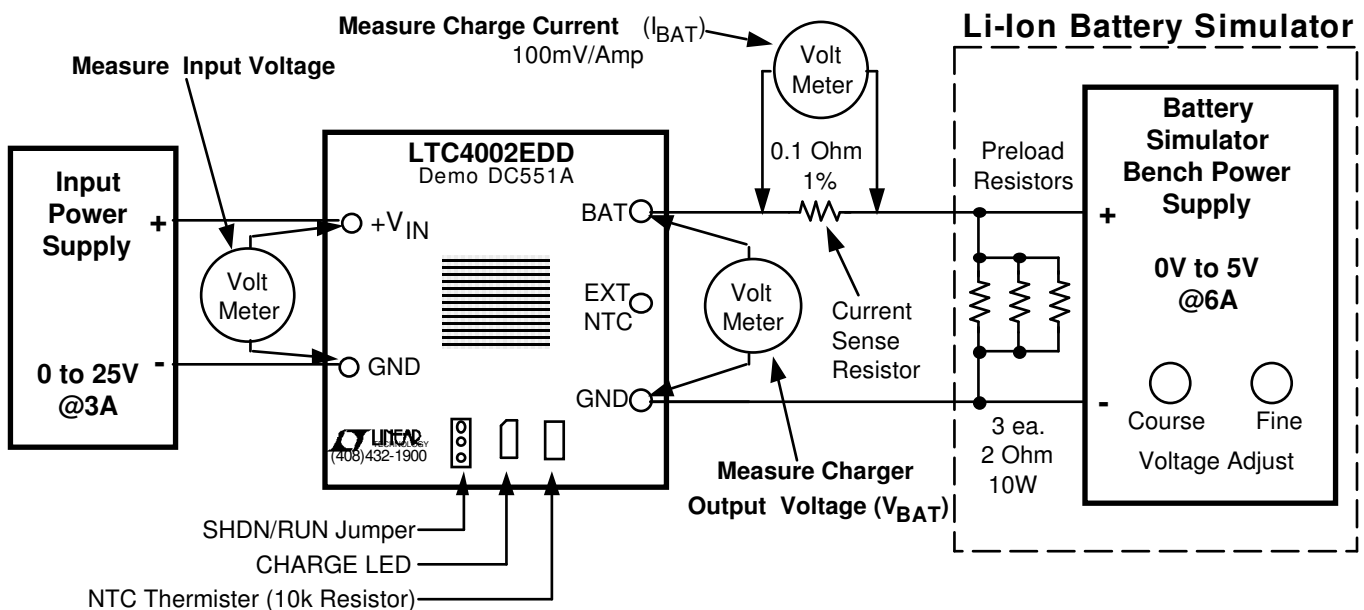

Test Equipment Required for Demo Board Evaluation

Lab power supply for input power	0 to 25V @ 3A
Digital multimeter for measuring input voltage (V_{IN})	3-1/2 digits
Digital multimeter for measuring battery voltage (V_{BAT})	4-1/2 digits
Digital multimeter for measuring charge current	3-1/2 digits
Li-Ion cell or *Battery Simulator	4.2V Rechargeable Li-Ion Cell

QUICK START GUIDE FOR DEMONSTRATION CIRCUIT 551

LITHIUM-ION BATTERY CHARGER WITH CHARGE TERMINATION

*Battery Simulator consists of;

Power supply with coarse and fine output voltage adjust controls	0 to 5V @ 6A
Power resistors (preload for power supply)	3ea 2• 10W

Battery Simulator

A battery simulator can be very useful for evaluating a battery charger. A simple battery simulator consists of a lab power supply with coarse and fine (or a multi-turn) voltage adjust controls and a power resistor connected to the power supply output terminals. With the resistor load connected, the power supply can source and sink current, similar to an actual battery. Any level of charge from a fully discharged to fully charged battery can be quickly simulated by simply

changing the battery simulator power supply voltage. A fully discharged Li-Ion cell will be approx. 2.6V to 3V and a fully charged cell will be either 4.1V or 4.2V depending on the battery chemistry. When the cell is nearly fully charged, small changes in battery voltage will result in large changes in charge current.

Of course, there are times when an actual battery is needed, for example when plotting a complete charge cycle from start to finish.

QUICK START PROCEDURE

With both power supplies set to 0V, connect the demo board to power supplies and meters as shown in Figure 1. The electrical connections between the charger output and the battery simulator must be high quality and a 0.1Ω sense resistor is recommended for the charge current measurement. The dc resistance in the charge current path should be kept to a minimum.

Undervoltage Lockout and Trickle Charge - After placing jumper (JP1) in the “RUN” position, begin increasing the input power supply voltage. At approximately 4.3V, the LTC4002 undervoltage lockout will allow the charger to start and the charge current will abruptly rise to approximately 300mA (30mV on the meter). This is the trickle charge current for a deeply discharged battery ($V_{BAT} < 2.9V$). Adjust the input supply to approximately 6V.

Trickle Charge Threshold and Constant Current Charge - Begin increasing the battery simulator power supply (V_{BAT}), observing the charger output voltage on the DVM. When the voltage exceeds

approximately 2.9V, the charger will suddenly enter the Constant Current portion of the charge cycle resulting in an abrupt increase in charge current to the programmed value of approximately 3A (300mV on the charge current DVM). This is the constant current mode. The CHRG LED will also turn on.

Constant Voltage Charge and CHRG LED Indicator - Continue slowly increasing the battery simulator power supply, thus simulating a battery accepting charge. The charge current should remain at the programmed value of 3A until the charger output voltage is within approximately 10mV of the preset charge voltage ($4.2V \pm 1\%$), at which time the charge current will begin to decrease. This is the beginning of the Constant Voltage portion of the charge cycle.

Continue very slowly increasing the battery simulator power supply until the CHRG LED turns off, and note the charge current level when it went off. The current level should be approximately 750mA $\pm 25\%$. The LED is an indicator that the battery is approaching full charge. It is not a charge complete indication. The charge cycle will continue until the 3 hour timer ends. (Note: when the LED

QUICK START GUIDE FOR DEMONSTRATION CIRCUIT 551

LITHIUM-ION BATTERY CHARGER WITH CHARGE TERMINATION

turns off, it remains off until a new battery is installed, the input power is cycled, or the charger is momentarily shut down).

Continue increasing the battery simulator power supply until the charge current drops to approximately 300mA (30mV on the charge current DVM), then read the charger output voltage on the DVM. This reading is the charger float voltage of $4.200V \pm 40mV$. Note: small changes in battery simulator voltage will result in large changes in charge current. Adjusting the simulator power supply to 4.2V will drop the charge current to 0mA.

Sleep Mode - To verify battery drain current in the sleep mode, remove the input supply voltage or shut the supply off, replace the 0.1Ω current sense resistor with a $1k\Omega$, and set the battery simulator power supply to approximately 4V. The charge current DVM will now read battery drain current with $1mV/\mu A$.

Misc - The input voltage can range from 5.2V to 24V with negligible effect on charge current or charge voltage specs. When applying input voltage greater than 20V, a solid tantalum capacitor is recommended in parallel with the existing ceramic input bypass capacitor to minimize voltage transients due to ringing when the input power is hot switched. Install a $10\mu F$ or larger, 35V tantalum capacitor at location C2 on the demo board.

The charger can be shutdown by moving the jumper (J1) from the "RUN" position to the "SHDN" position.

To verify the temperature qualification feature, remove the 10k resistor R3 and connect a resistor substitution box to the "EXT NTC" terminals. Refer to the LTC4002 data sheet for resistor values that will either allow the charger to provide charge current or stop charging because of temperature extremes. If an actual thermistor is used, it must be mounted near the battery, not on the board.

QUICK START GUIDE FOR DEMONSTRATION CIRCUIT 551 LITHIUM-ION BATTERY CHARGER WITH CHARGE TERMINATION

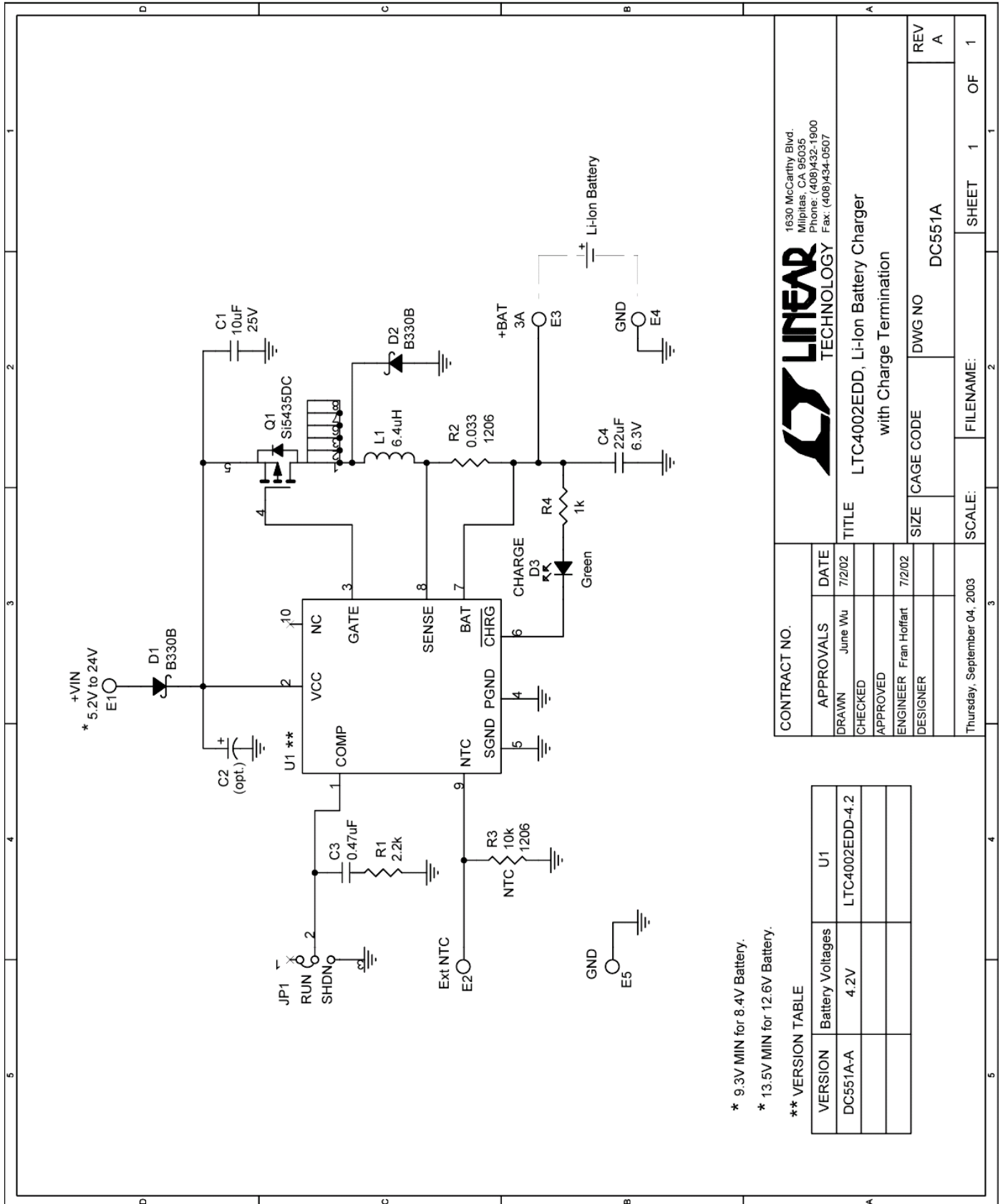

1630 McCarthy Blvd.
Milpitas, CA 95035
Phone: (408)432-1900
Fax: (408)434-0907

CONTRACT NO.		TITLE	
APPROVALS	DATE	LTC4002EDD, Li-Ion Battery Charger with Charge Termination	
DRAWN June Wu	7/2/02	SIZE (CAGE CODE)	DWG NO DC551A
CHECKED		SCALE:	SHEET 1 OF 1
APPROVED		FILENAME:	
ENGINEER Fran Hoffart	7/2/02		
DESIGNER			
Thursday, September 04, 2003			

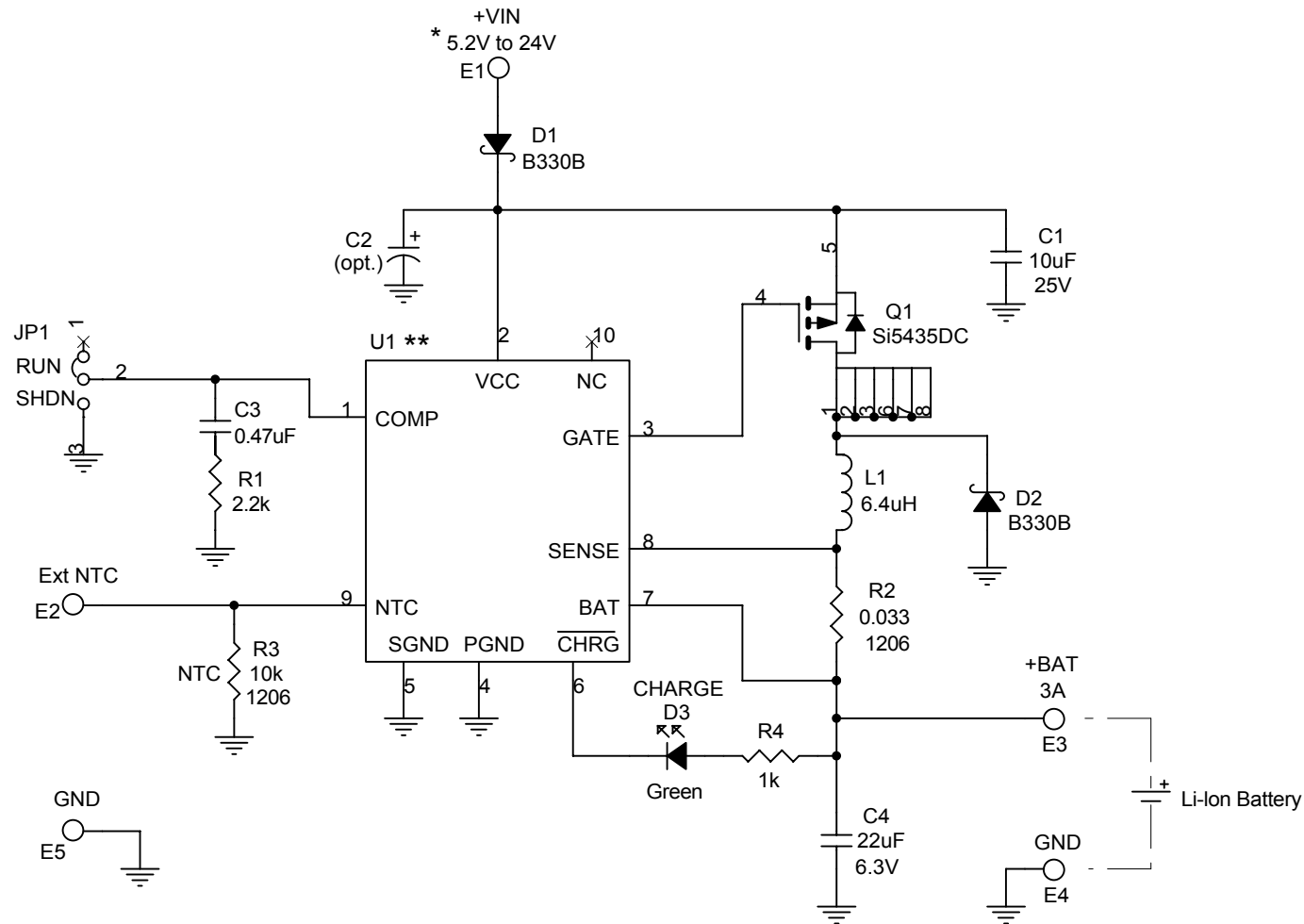

* 9.3V MIN for 8.4V Battery.

* 13.5V MIN for 12.6V Battery.

** VERSION TABLE

VERSION	Battery Voltages	U1
DC551A-A	4.2V	LTC4002EDD-4.2

CONTRACT NO.		 1630 McCarthy Blvd. Milpitas, CA 95035 Phone: (408)432-1900 Fax: (408)434-0507		TITLE LTC4002EDD, Li-Ion Battery Charger with Charge Termination	
APPROVALS					
DRAWN	June Wu	7/2/02			
CHECKED					
APPROVED					
ENGINEER	Fran Hoffart	7/2/02			
DESIGNER					
Thursday, September 04, 2003		SCALE:	FILENAME:	DWG NO DC551A	REV A
				SHEET 1 OF 1	

Item	Qty	Reference	Part Description	Manufacture / Part #
1	1	C1	CAP., X5R, 10uF, 25V, 20% 1210	Taiyo Yuden, TMK325BJ106MM
2	0	C2 (OPT)	CAP., TANT., 7343	OPT.
3	1	C3	CAP., X5R, 0.47uF, 6.3V, 20% 0603	AVX, 06036D474MAT2A
4	1	C4	CAP., X5R, 22uF, 6.3V, 20% 1210	Taiyo Yuden, JMK325BJ226MM
5	2	D1,D2	Schottky Rec., B330B SMB	DIODES INC., B330B-13
6	1	D3	LED, Green	Panasonic, LN1351C-(TR)
7	5	E1-E5	TESTPOINT, TURRET, .094"	MILL-MAX, 2501-2
8	1	JP1	0.079 SINGLE ROW HEADER, 3 PIN	COMM CON, 2802S-03-G1
9	1	SHUNT (1-2)	SHUNT,	COMM CON, CCIJ2MM-138G
10	1	L1	INDUCTOR, 6.4uH, D104C	TOKO, 919AS-6R4M
11	1	Q1	P-MOSFET, Si5435DC 1206-8	Vishay Siliconix, Si5435DC-T1
12	1	R1	RES., CHIP, 2.2K, 1/16W, 5% 0603	AAC, CR16-222JM
13	1	R2	RES., CHIP, 0.033, 1/2W, 1% 1206	THIN FILM TECH., RL1632R-R033F
14	1	R3	RES., CHIP, 10k, 1/4W, 5% 1206	AAC, CR18-103JM
15	1	R4	RES., CHIP, 1k, 1/16W, 5% 0603	AAC, CR16-102JM
16	1	U1	I.C., LTC4002EDD DFN10	Linear Tech. LTC4002EDD
17	1		PRINTED CIRCUIT BOARD	DEMO CIRCUIT #551A-A
18	1		STENCIL	STENCIL #551A-A