

THIS DRAWING IS A CONTROLLED DOCUMENT.

PART NUMBER	REV	FIRST USED
680327-1	C	122500-1
680327-2	C	565435-5
680327-3	C	354500-1

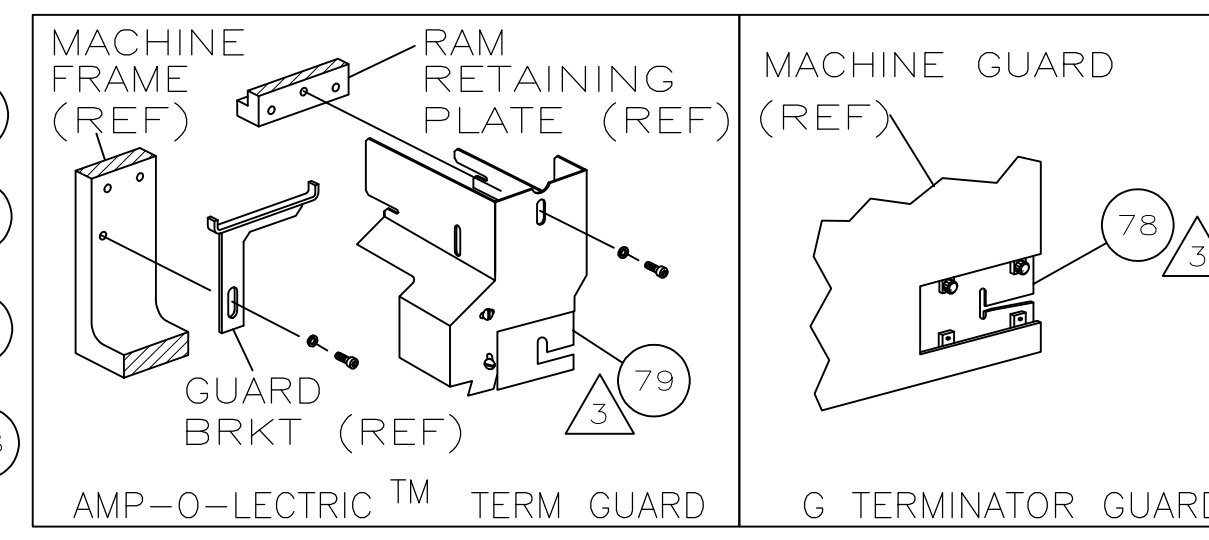
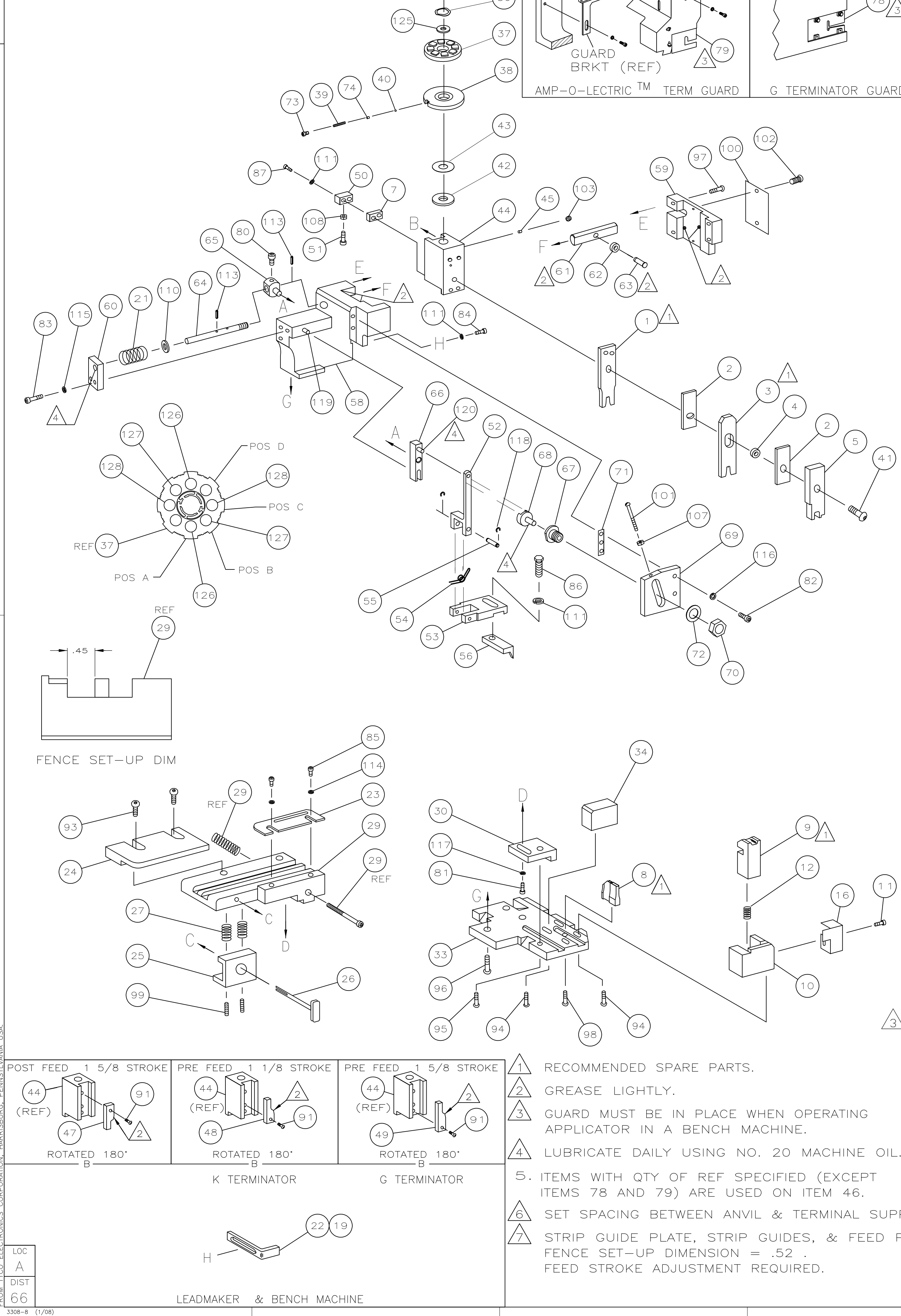

AMP P/N		MFG P/N		CRIMPING DATA	
170382				CRIMP HEIGHT	
286501	P82404050	PAD LTR		WIRE SIZE	
		A	.054 ±.002 [1.38 ±.05mm]	16	
		B	.048 ±.002 [1.22 ±.05mm]	18	
		C	.043 ±.002 [1.10 ±.05mm]	20	
		D	NOT	USED	
CRIMP		SIZE	TYPE	RANGE	
WIRE		.080 [2.03mm]	F	20-16	
INSUL		.140 [3.56mm]	F	.080-.120	
WIRE STRIP LENGTH	TERM APPL SPEC	FEED	APPL INSTRUCTION	SET UP GAGE	LAYOUT
-	114-5056	.512	408-8040	458637-1	L1789

QTY	REF	REF	REF	REF	PART NO	DESCRIPTION	ITEM NO
2	2	2	-	-	3-354779-6	PIN, WIRE DISC (.3170)C	129
2	2	2	-	-	2-354779-6	PIN, WIRE DISC (.3120)B	127
2	2	2	-	-	1-354779-4	PIN, WIRE DISC (.3060)A	126
1	1	1	-	-	986950-1	WASHER, FLAT PRECISION	125
1	1	1	-	-	217238-1	GENERAL INSTRUCTION PACKAGE	124
1	1	1	-	-	4088040	SF APPL INST 408-8040	123
							122
							121
REF	REF	REF	-	-	1-21030-1	PIN,DOWEL(Ø.187x.50)LEVER	120
REF	REF	REF	-	-	1-21030-6	PIN,DOWEL(Ø.187x1.25)HOUSING	119
REF	REF	REF	-	-	21045-3	RING,RET "C"(Ø.187)FD FING PIN	118
1	1	1	-	-	21024-5	WASHER, LOCK(#10)ADJ BLOCK	117
REF	REF	REF	-	-	21024-5	WASHER,LOCK(#10)ADJ PLATE	116
REF	REF	REF	-	-	21024-5	WASHER,LOCK(#10)FEED GDE ROD	115
2	2	2	-	-	21024-2	WASHER,LOCK(#4)FRONT STP GUIDE	114
REF	REF	REF	-	-	5-21028-1	PIN,SLT SPR(Ø.125x.50)ADJ ROD	113
							112
4	4	4	-	-	21024-4	WASHER,LOCK(#8)STRIPPER	111
REF	REF	REF	-	-	21899-4	WASHER,FLAT(Ø5/16)SCREW ADJ	110
							109
1	1	1	-	-	21018-5	NUT,HEX(6-32)	108
REF	REF	REF	-	-	21018-5	NUT,HEX(6-32)FEED ADJ	107
							106
							105
							104
1	1	1	-	-	21009-2	SCR,SKT SET(1/4-20x.25 LW)RAM	103
2	2	2	-	-	21017-2	SCR,DRIVE(#2x.19)ID PLATE	102
REF	REF	REF	-	-	6-23715-5	SCR,PAN HD(6-32x1.50)FEED ADJ	101
1	1	1	-	-	461264-1	PLATE, IDENTIFICATION	100
2	2	2	-	-	5-21006-6	SCR,SET(10-32x.75)DRAG	99
1	1	1	-	-	22733-8	SCR,BHC(8-32x.38 LW)ANVIL	98
REF	REF	REF	-	-	2-21002-9	SCR,BHC(10-32x.75)CAP	97
REF	REF	REF	-	-	2-22733-8	SCR,BHC(1/4-20x.62)HOUSING	96
REF	REF	REF	-	-	2-21002-7	SCR,BHC(10-32x.50)SG ADJ BLOCK	95
4	4	4	-	-	2-21002-2	SCR,BHC(8-32x.50)TERM H DWN	94
2	2	2	-	-	2-21002-3	SCR,BHC(8-32x.62)R STP GDE	93
							92
1	1	1	-	-	1-21002-7	SCR,BHC(6-32x.38)CAM	91
							90
							89
							88
2	2	2	-	-	2-21000-8	SCR,SHC(8-32x.62)DEP-HOLD	87
1	1	1	-	-	2-22603-0	SCR,HEX HD(8-32x.31)FEED FINGER	86
2	2	2	-	-	1-21000-3	SCR,SHC(4-40x.25)F ST GUIDE	85
1	1	1	-	-	2-21000-7	SCR,SHC(8-32x.50)STRIPPER	84
REF	REF	REF	-	-	3-21000-7	SCR,SHC(10-32x.75)FEED ROD GD	83
REF	REF	REF	-	-	3-21000-6	SCR,SHC(10-32x.62)FD ADJ BLK	82
1	1	1	-	-	3-21000-4	SCR,SHC(10-32x.38)SG ADJ BL	81
REF	REF	REF	-	-	3-21000-4	SCR,SHC(10-32x.38)PIVOT BLK	80
-	REF	-	-	-	455749-1	GUARD, WINDOW	79
REF	-	-	-	-	679532-1	INSERT, GUARD	78
							77
							76
							75
1	1	1	-	-	690603-1	SPRING, ASSIST	74
1	1	1	-	-	23030-1	SCR,SHC(6-32x.25 SL)INS DISC	73
REF	REF	REF	-	-	458109-1	WASHER, SPECIAL	72
REF	REF	REF	-	-	690517-1	SPACER	71
-3	-2	-1	U/M				
QTY RECD PER ASSY		PARTS LIST		DESCRIPTION		ITEM NO	

REV	DESCRIPTION	MECH	FEED
-1	LEADMAKER	MECH	POST FEED
-2	BENCH MODEL K	MECH	PRE FEED
-3	BENCH MODEL G	MECH	PRE FEED

QTY	REF	REF	REF	REF	PART NO	DESCRIPTION	ITEM NO
4	REF	REF	REF	-	22594-8	NUT,HEX(1/2-20)	70
REF	REF	REF	REF	-	240628-1	PLATE, ADJUSTMENT	69
REF	REF	REF	REF	-	240626-1	SHAFT, PIVOT	68
REF	REF	REF	REF	-	240633-1	BUSHING	67
REF	REF	REF	REF	-	455680-1	LEVER, INTERMEDIATE	66
REF	REF	REF	REF	-	240629-1	BLOCK, PIVOT	65
REF	REF	REF	REF	-	240632-2	SCREW, ADJ FEED ROD	64
REF	REF	REF	REF	-	240659-3	PIN, CAM ROLLER	63
REF	REF	REF	REF	-	240658-1	ROLLER, CAM	62
REF	REF	REF	REF	-	454398-2	ROD, FEED	61
REF	REF	REF	REF	-	454178-1	GUIDE, FEED ROD	60
REF	REF	REF	REF	-	454220-1	CAP, RAM	59
REF	REF	REF	REF	-	454485-1	HOUSING	58
							57
1	1	1	-	-	458537-2	PAWL, FEED	56
REF	REF	REF	REF	-	240624-1	PIN, FEED FINGER	55
REF	REF	REF	REF	-	691499-1	SPRING, FEED FINGER	54
REF	REF	REF	REF	-	690541-1	HOLDER, FEED FINGER	53
REF	REF	REF	REF	-	455679-1	LEVER, TERMINAL FEED ARM	52
1	1	1	-	-	811242-2	BUMPER, HOLDDOWN	51
1	1	1	-	-	690753-1	SPACER, TONKER	50
1	-	-	-	-	690602-6	CAM, PRE-FEED 1 5/8 ST	49
-	1	-	-	-	690602-5	CAM, PRE-FEED 1 1/8 ST	48
-	-	1	-	-	690501-4	CAM, POST-FEED 1 5/8 ST	47
1	1	1	-	-	459456-1	APPLICATOR, BASIC (SUBASSY)	46
1	1	1	-	-	690191-1	PLUG, NYLON	45
1	1	1	-	-	455673-1	RAM	44
1	1	1	-	-	690125-1	WASHER, LAMINATED	43
1	1	1	-	-	690124-1	WASHER, RAM	42
1	1	1	-	-	7-21002-9	BOLT, CRIMPER(5/16x1.00)	41
1	1	1	-	-	23241-6	BALL, STEEL	40
1	1	1	-	-	690170-1	SPRING, COMPRESSION	39
1	1	1	-	-	690142-1	DISC, INSULATION	38
1	1	1	-	-	354777-1	WIRE DISC, PLASTIC	37
1	1	1	-	-	22480-5	WASHER, SPRING	36
1	1	1	-	-	690212-1	POST, RAM	35
1	1	1	-	-	690786-1	SUPPORT, TERMINAL	34
REF	REF	REF	REF	-	455675-1	PLATE, BASE	33
							32
							31
REF	REF	REF	REF	-	455689-1	BLOCK, STRIP GUIDE ADJ	30
1	1	1	-	-	318042-1	STRIP GUIDE PLATE ASSY	29
							28
2	2	2	-	-	1-22284-0	SPRING, DRAG	27
1	1	1	-	-	690546-1	LEVER, DRAG RELEASE	26
1	1	1	-	-	240792-5	DRAG, TERMINAL	25
1	1	1	-	-	4-690504-1	GUIDE, STRIP (REAR)	24
1	1	1	-	-	690438-1	GUIDE, STRIP (FRONT)	23
-	-	1	-	-	690472-9	STRIPPER	22
REF	REF	REF	REF	-	4-22284-9	SPRING, FEED RETURN	21
							20
1	1	-	-	-	691353-1	STRIPPER	19
							18
							17
1	1	1	-	-	318563-1	GUARD, CHIP, FRONT	16
							15
							14
							13
1	1	1	-	-	3-22280-3	SPRING, SHEAR	12
1	1	1	-	-	690461-1	STOP, SHEAR	11
1	1	1	-	-	690459-1	HOLDER, SHEAR (FRONT)	10
1	1	1	-	-	1-454276-9	SHEAR, FLOAT (FRONT)	9
1	1	1	-	-	9-683403-0	ANVIL	8
1	1	1	-	-	240641-1	SPACER, DEPRESSOR (REAR)	7
							6
1	1	1	-	-	1-455889-4	DEPRESSOR, SHEAR (FRONT)	5
1	1	1	-	-	1-238011-0	SPACER, BLOCK CRIMPER	4
1	1	1	-	-	7-456134-7	CRIMPER, INSULATION	3
2	2	2	-	-	455888-8	SPACER, CRIMPER	2
1	1	1	-	-	1-456405-6	CRIMPER, WIRE	1
-3	-2	-1	U/M				
QTY RECD PER ASSY		PARTS LIST		DESCRIPTION		ITEM NO	

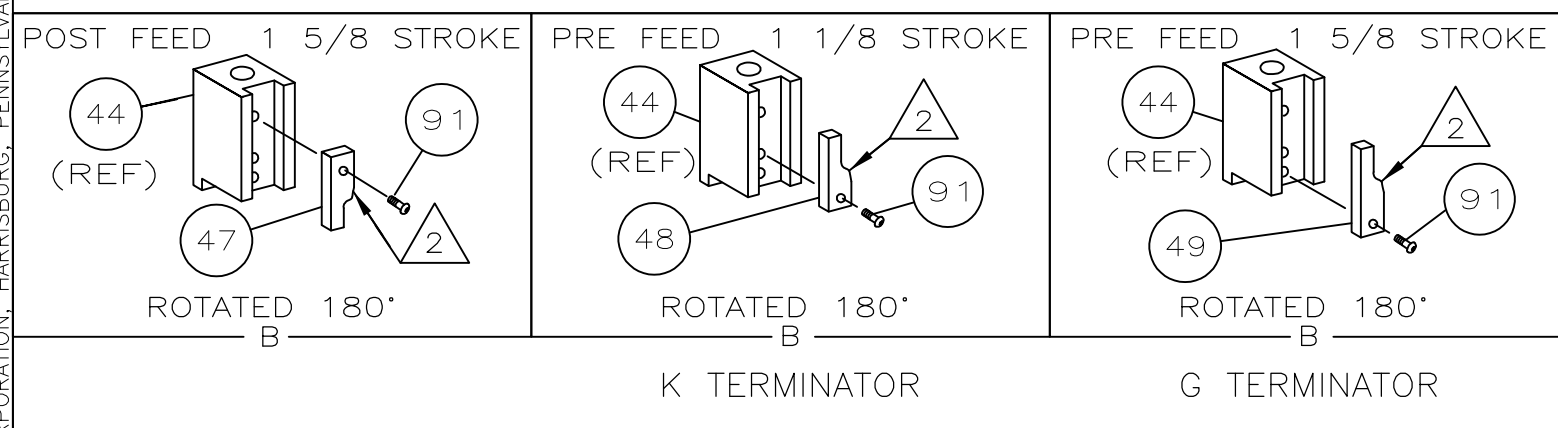

- 1 RECOMMENDED SPARE PARTS.
- 2 GREASE LIGHTLY.
- 3 GUARD MUST BE IN PLACE WHEN OPERATING APPLICATOR IN A BENCH MACHINE.
- 4 LUBRICATE DAILY USING NO. 20 MACHINE OIL.
- 5 ITEMS WITH QTY OF REF SPECIFIED (EXCEPT ITEMS 78 AND 79) ARE USED ON ITEM 46.
- 6 SET SPACING BETWEEN ANVIL & TERMINAL SUPPORT TO .13 .
- 7 STRIP GUIDE PLATE, STRIP GUIDES, & FEED PAWL REPOSITIONING REQUIRED. FENCE SET-UP DIMENSION = .52 . FEED STROKE ADJUSTMENT REQUIRED.

LOC	DIST	REV	DATE	BY	CHK	APPV	DATE	REV	BY	CHK	APPV	DATE	REV	BY	CHK	APPV
A	66															

REV	DESCRIPTION	DATE	BY	CHK	APPV
C	ECR-10-018277	8-2010	MY	GB	

DIMENSIONS:	TOLERANCES UNLESS OTHERWISE SPECIFIED:
INCHES	0 PLC ±.005
	1 PLC ±.002
	2 PLC ±.001
	3 PLC ±.0005
	4 PLC ±.0002
ANGLES:	±.005
SURFACE TEXTURE:	√

DRW	DATE	MATERIAL	HEAT TREAT
R.O. WILSON	6-21-96	-	-
CHK	6-25-96		
C. ERISMAN			
APVD	6-26-96		
T. ELBIN			
NAME	SIDE FEED HDM APPLICATOR		
SCALE	SIZE	DRAWING NO	SHEET
-	A1	680327	1 of 1
REV	BY	CHK	APPV

CUSTOMER ACCESSIBLE PRODUCTION DRAWING