

LOC	REV	DATE	BY	APP'D
AA	22			
B	REV PER ECO-08-026214	04SEP2008	RQ	TX
C	ECO-11-015766	30MAY2011	EL	LR

**MECHANICAL:**

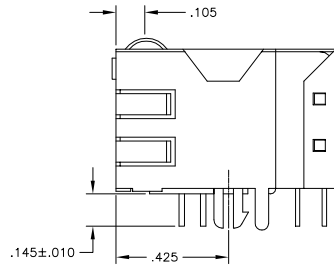

**766P9 SERIES MAGNETIC CIRCUIT**

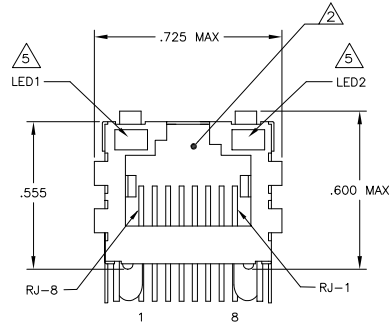
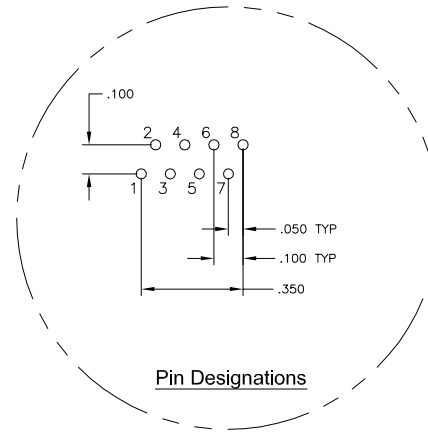
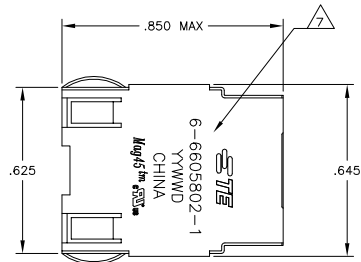
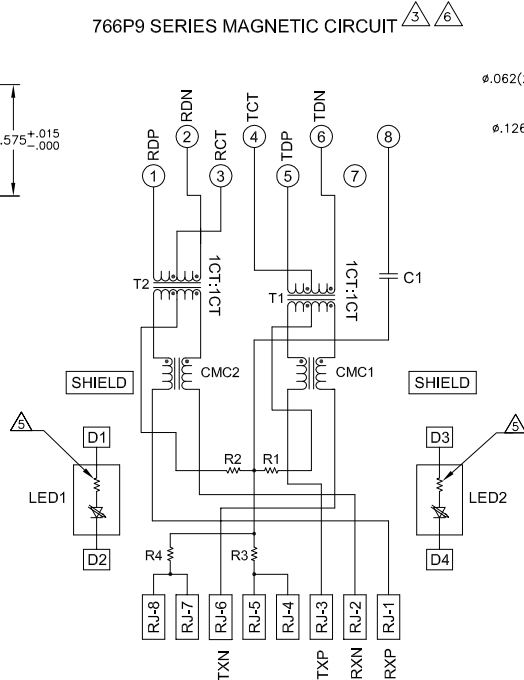

C1=1000pF, 2kV CAPACITOR  
R1-R4 = 75 OHMS, 1/16 W RESISTORS

- MATERIALS:**
- HOUSING - THERMOPLASTIC PET POLYESTER FLAMMABILITY RATING UL 94V-0.
  - SHIELD - .010" THICK, C26800 BRASS PREPLATED WITH 30μINCH MIN SEMI-BRIGHT NICKEL, SOLDER TABS POST DIPPED WITH 100μINCH MIN SAC SOLDER.
  - MOD JACK CONTACTS - 0.0157" x 0.018" PHOSPHOR BRONZE, 50μINCH MIN OVERALL NICKEL UNDERPLATE, WITH SELECT 50μINCH MIN HARD GOLD FINISH PLATE. SOLDER TAILS WITH 100μINCH MIN MATTE TIN AND/OR SAC SOLDER DIP.
  - LIGHT EMITTING DIODE(LED) - DIFFUSED EPOXY LENS, .020" x .020" CARBON STEEL WIREFRAME LEADS PRE-PLATED WITH 80μINCH SILVER OVER 40μINCH NICKEL UNDERPLATE OVER 40μINCH COPPER UNDERPLATE, POST-PLATED WITH 100μINCH MIN MATTE TIN AND/OR SAC SOLDER DIP OR PURE TIN SOLDER DIP.
- RJ45 JACK CAVITY CONFORMS TO FCC RULES AND REGULATIONS PART 68, SUB PART F.**
- MAGNETICS**
- IMPEDANCE: 100 OHMS
  - TURNS RATIO (CHIP: CABLE): TX = 1:1, RX = 1:1
  - OPEN CIRCUIT INDUCTANCE (OCL): 350μH MIN @100kHz, 0.1VRMS, 8mADC BIAS FROM 0°C TO 70°C, TX AND RX
  - PERFORMANCE @ 25°C:
  - INSERTION LOSS (IL): 1.1dB MAX FROM 0.5MHz TO 100MHz
  - RETURN LOSS (RL): 18dB MIN FROM 0.5MHz TO 30MHz
  - 18-20LOG(f/30)dB MIN FROM 30.1MHz TO 60MHz
  - 12dB MIN FROM 60.1MHz TO 80MHz
  - CROSSTALK ATTENUATION: 35dB MIN FROM 0.5MHz TO 40MHz
  - 33-20xLOG(f/50)dB MIN FROM 40.1MHz TO 100MHz
  - COMMON MODE REJECTION RATIO (CMRR): 30dB MIN FROM 0.5MHz TO 100MHz
  - ISOLATION VOLTAGE: 2250VDC (MAX) FOR 60 SECONDS WITH A RISE TIME OF 500V/SEC.
- 4. OPERATING TEMPERATURE: FROM 0°C - +70°C.**
- LED WITH 250 OHM RESISTORS LED IS DRIVEN WITH 5V VOLTAGE AND THE MAX OPERATING CURRENT IS 20mA.**
- LED COLOR :** DOMINANT WAVELENGTH (AD): GREEN 568 nm TYP @ VF=5V  
FORWARD CURRENT (IF): GREEN 12 mA TYP @ VF=5V  
DOMINANT WAVELENGTH (AD): YELLOW 588 nm TYP @ VF=5V  
FORWARD CURRENT (IF): YELLOW 13 mA TYP @ VF=5V

INDICATED CONNECTIONS ARE FOR HUB CONFIGURATION. THE MAGNETICS ARE SYMMETRICAL, AND SUPPORT AUTO-MDI/MIDX.

TE CONNECTIVITY LOGO, PART NUMBER, DATE CODE, COUNTRY OF ORIGIN AND AGENCY APPROVAL MARKING IN APPROXIMATE LOCATION SHOWN.

THESE PARTS ARE RECOMMENDED FOR WAVE SOLDERING PROCESS, PREHEAT TEMPERATURE IS 120°C TO 160°C, 120 SECONDS TO 180 SECONDS, PEAK SOLDERING TEMPERATURE IS 260 °C MAX, 10 SECONDS MAX.

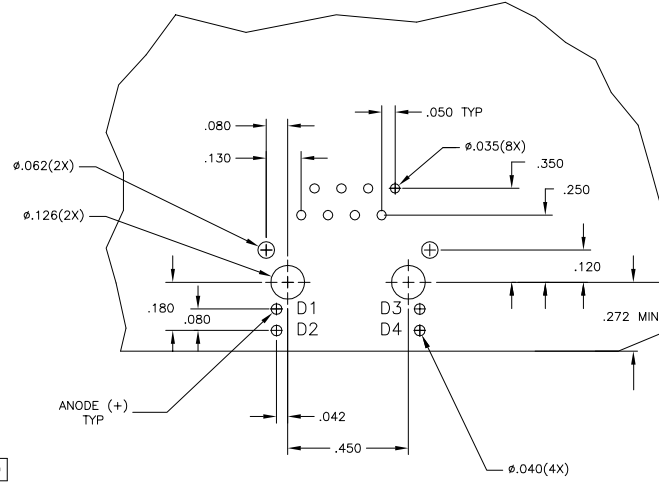

**Suggested PCB Layout (Component Side)**

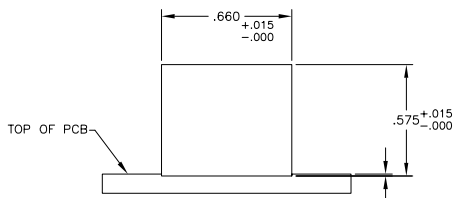

**Suggested Panel Cutout**

GREEN	GREEN	6-6605802-1
YELLOW	GREEN	5-6605802-2
LED1	LED2	PART NUMBER

THIS DRAWING IS A CONTROLLED DOCUMENT.		REV. 1 - VARELA - 02/03/03	DATE	BY	APP'D
DIMENSIONS: INCHES		CHK. S. FAROLE	02/03/03		
0 P.C. ± .010		APP'D. S. FAROLE	02/03/03		
1 P.C. ± .008		NAME			
2 P.C. ± .010		1X1 MAG45(TM), MODULAR JACK,			
3 P.C. ± .010		7HS SCHEMATIC, 766P9 SERIES CIRCUIT, SHIELDED,			
4 P.C. ± .010		DECOUPLING CAPACITOR, WITH RESISTOR LEADS			
MATERIAL		SIZE	DATE CODE	DRAWING NO	RESTRICTED TO
FINISH		A1	00779	C=6605802	
		CUSTOMER DRAWING		SCALE	SHEET 1 OF 1