

THIS DRAWING AND THE INFORMATION SET FORTH HEREON ARE THE PROPERTY OF TYCO ELECTRONICS CORPORATION AND ARE TO BE HELD IN TRUST AND CONFIDENCE. PUBLICATION, DUPLICATION, DISCLOSURE OR USE FOR ANY PURPOSE NOT EXPRESSLY AUTHORIZED IN WRITING BY TYCO ELECTRONICS CORPORATION IS PROHIBITED.

REVISION		
REV	DESCRIPTION	DATE
F	REVISED PER DCR NUMBER MP060008	4/17/06

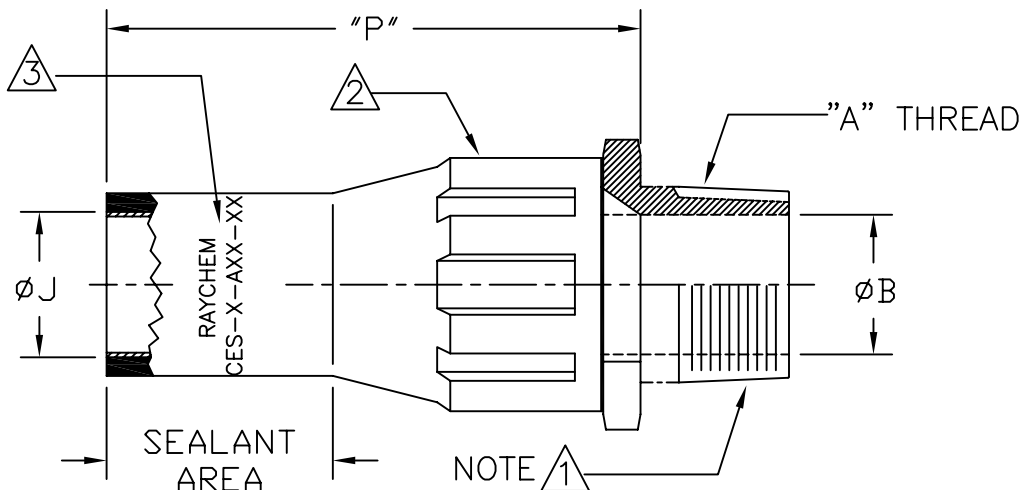

PART NUMBER	A NATIONAL PIPE THREAD	ØJ		ØB ±.02	P REC REF
		EXP MIN	REC MAX		
CES-1-A50-XX	1/2-14	.50 [12,70]	.17 [4,31]	.50 [12,7]	2.45 [62,23]
CES-2-A50-XX	1/2-14	.75 [19,05]	.25 [6,35]	.50 [12,7]	2.45 [62,23]
CES-2-A75-XX	3/4-14	.75 [19,05]	.25 [6,35]	.75 [19,05]	2.45 [62,23]
CES-2-A100-XX	1-11 1/2	.75 [19,05]	.25 [6,35]	.75 [19,05]	2.45 [62,23]
CES-3-A100-XX	1-11 1/2	1.20 [30,48]	.50 [12,70]	1.01 [25,66]	3.55 [90,17]
CES-3-A150-XX	1 1/2-11 1/2	1.20 [30,48]	.50 [12,70]	1.10 [27,94]	3.55 [90,17]
CES-4-A150-XX	1 1/2-11 1/2	1.60 [40,64]	.75 [14,28]	1.48 [37,59]	3.85 [97,79]

NOTES:

1. THE LAST "XX" IN THE PART NUMBER DESIGNATES MATERIAL AS SHOWN BELOW:  
 "AL": ALUMINUM 6061 T-6 WITH FINISH OF HARD ANODIZE PER MIL-A-8625, TYPE III, CLASS 2, DYED BLACK.  
 "SS": STAINLESS STEEL TYPE 316, WITH FINISH OF PASSIVATE PER QQ-P-35, OR MIL-S-5002 FOR STANDARD BLACK NYLON MATERIAL, OMIT THE LAST "X" IN THE PART NUMBER.
2. HEAT SHRINKABLE BOOT MATERIAL IN ACCORDANCE WITH -3 POLYOLEFIN
3. PART IS TO BE MARKED AS SHOWN, REPLACE X'S WITH APPROPRIATE CHARACTERS. THE FIRST "X" IN THE PART NUMBER IS SUBSTITUTED BY THE SIZE 1-5, THE SECOND SET OF "X's" REFERS TO NPT SIZE.
4. FACTORY APPLIED HOT MELT ADHESIVE IS STANDARD.

SPECIFICATION CONTROL DRAWING		
<b>tyco</b> <b>Electronics</b>	Tyco Electronics Corporation 300 Constitution Drive Menlo Park, CA. USA 94025	Product Brand: <b>Raychem</b>
TITLE CABLE ENTRY SEAL, SIZE 1-4 SINGLE ENTRY, NPT THREADED		
© 2006 Tyco Electronics Corporation. All rights reserved		
SIZE A	CODE IDENT. NO. 06090	DWG. NO. CES-X-AXXX-XX
DO NOT SCALE THIS DRAWING		SHEET 1 OF 1

If this document is printed it becomes uncontrolled.  
Check for the latest revision.