

THIS DRAWING IS UNPUBLISHED. RELEASED FOR PUBLICATION 20
 © COPYRIGHT 20 BY - ALL RIGHTS RESERVED.

REVISIONS				
P	LTR	DESCRIPTION	DATE	APVD
	A	PRODUCTION RELEASE	13JUN2019	JW SH
	A1	REVISED PER ECO-20-016374	19NOV2020	SH SZ
	A2	REVISED PER ECO-20-017424	10DEC2020	SH SZ

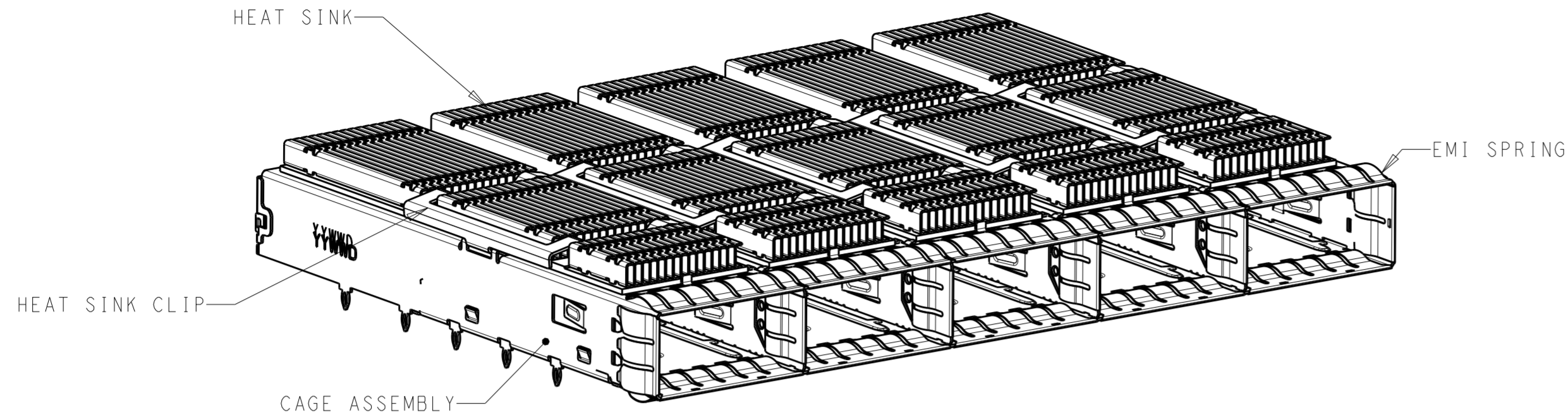

2343987-1 AS SHOWN

- 1 CAGE ASSEMBLY: STAINLESS STEEL.
HEAT SINK: ALUMINUM/NICKEL PLATE.
HEAT SINK CLIP: STAINLESS STEEL.
EMI SPRING: COPPER ALLOY/NICKEL PLATE.
- 2 REFERENCE APPLICATION SPECIFICATION 114-32023 FOR RECOMMENDED DRILL HOLE DIAMETER AND PLATING THICKNESS. BOARD LAYOUT PER THIS PRINT.
- 3 DATUM AND BASIC DIMENSION ESTABLISHED BY CUSTOMER.
- 4 DATE CODE (YYWW) MARKED APPROXIMATELY AS SHOWN.
- 5. MATES WITH QSFP DD MSA COMPATIBLE TRANSCEIVER.
- 6. MINIMUM PC BOARD THICKNESS: SINGLE SIDED: 1.45 MIN
DOUBLE SIDED: 2.20 MIN
- 7 ONLY FOR VERSION WITH REAR EONS
- 8 PROPOSAL ONLY

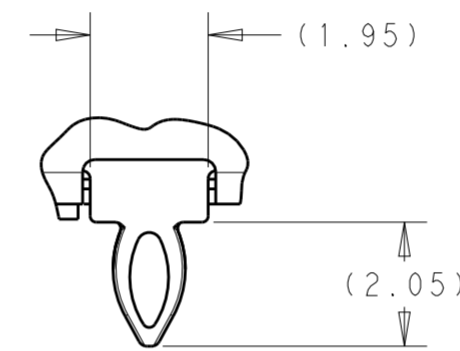

DETAIL A
SCALE 8:1

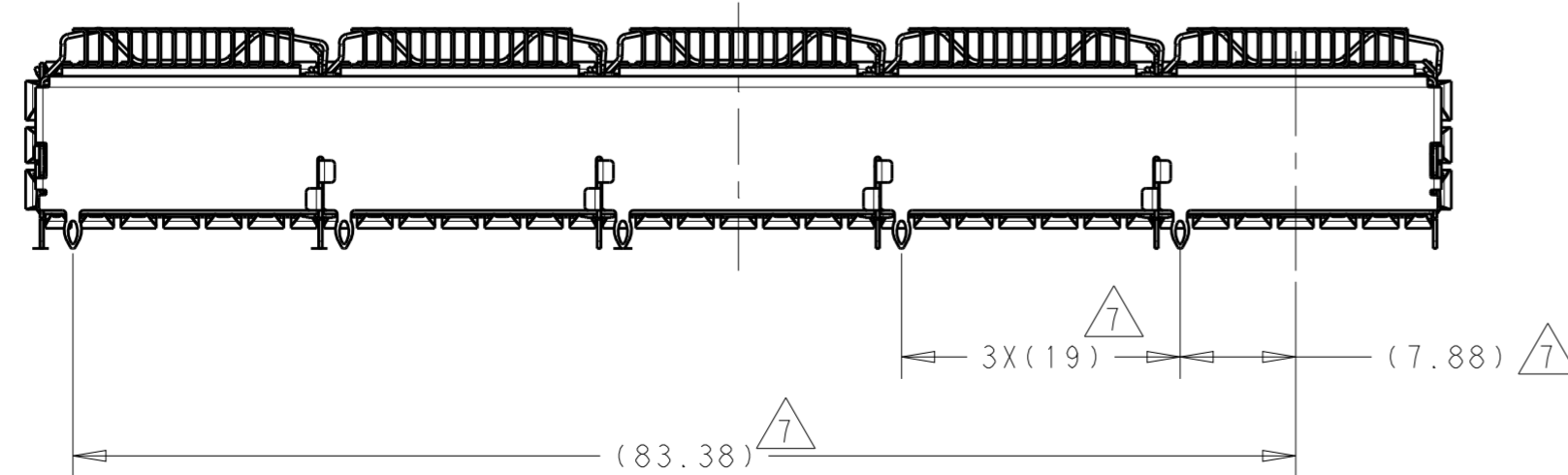
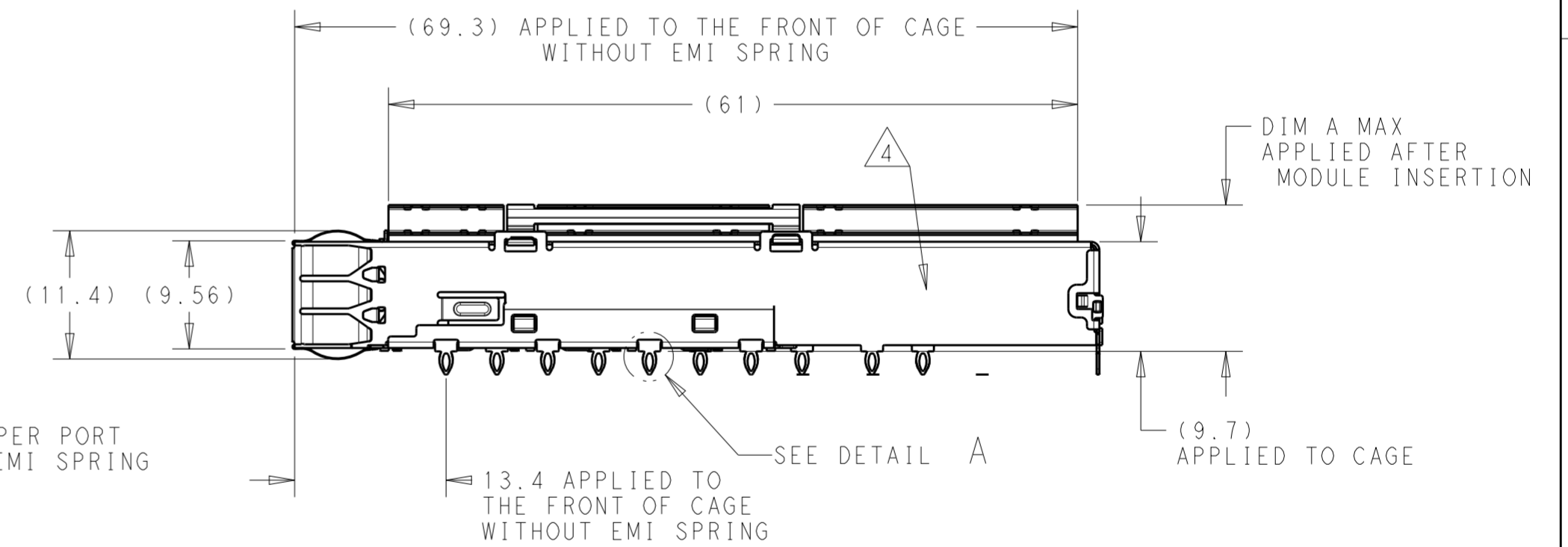
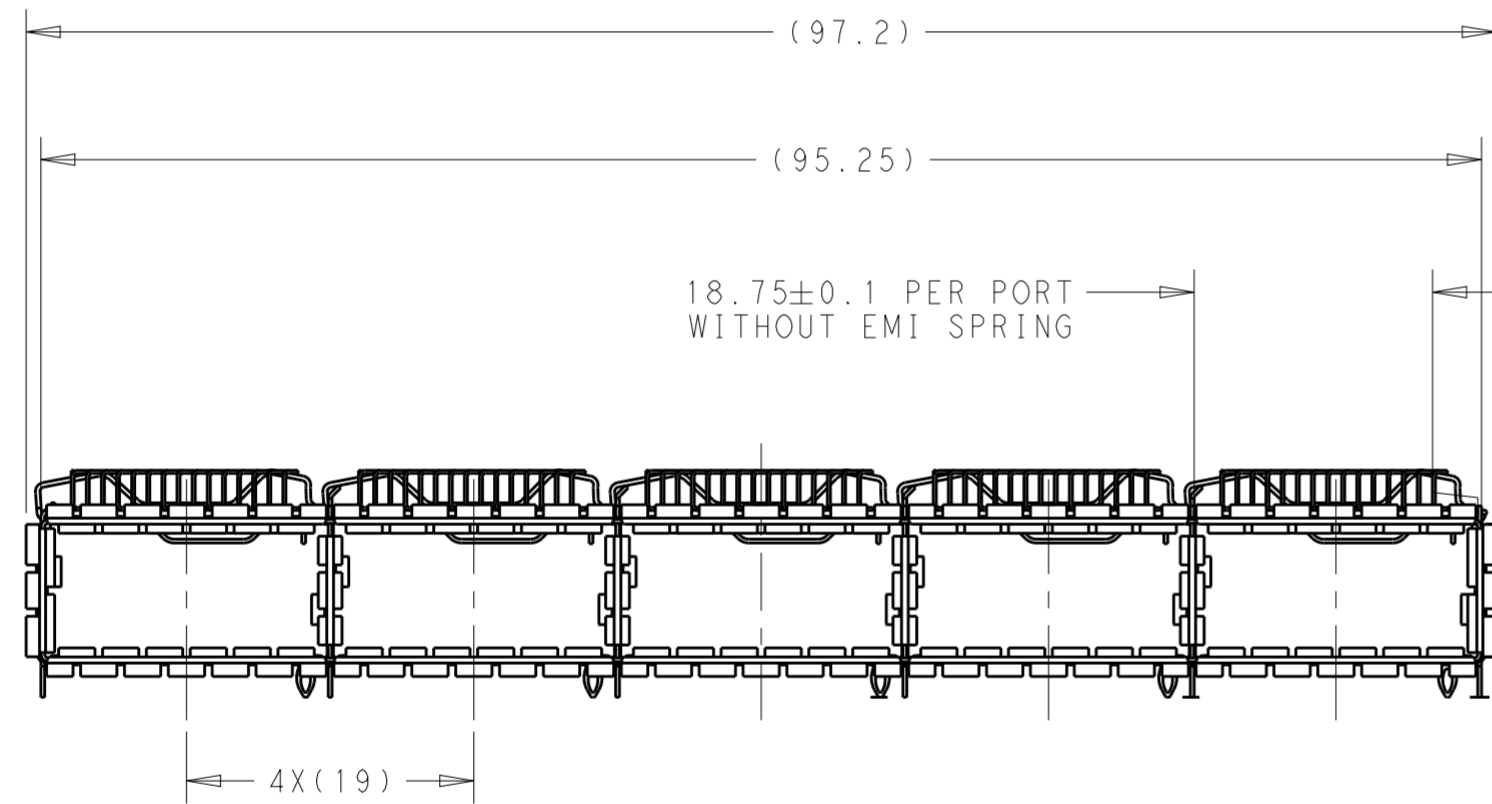

SCALE 2:1

8	W/ REAR EONS	19.75	CUSTOMIZED	2343987-7
8	W/O REAR EONS	23	NET	1-2343987-3
8	W/O REAR EONS	16	SAN	1-2343987-2
8	W/O REAR EONS	13.7	PCI	1-2343987-1
	W/ REAR EONS	23	NET	2343987-3
	W/ REAR EONS	16	SAN	2343987-2
	W/ REAR EONS	13.7	PCI	2343987-1
	REMARK	DIM A	HEATSINK	PART NUMBER

THIS DRAWING IS A CONTROLLED DOCUMENT.		DWN J. WANG 13SEP2018	TE Connectivity		
DIMENSIONS: mm		CHK S. HAN 13SEP2018			
TOLERANCES UNLESS OTHERWISE SPECIFIED:		APVD S. HAN 13SEP2018			
0 PLC ±0.25 1 PLC ±0.25 2 PLC ±0.25 3 PLC ± 4 PLC ± ANGLES ± FINISH ±		PRODUCT SPEC -	NAME CAGE ASSEMBLY WITH HEATSINK THRU BEZEL, 1X5, QSFPDD		
MATERIAL -1		APPLICATION SPEC -	SIZE A2	CAGE CODE -	DRAWING NO C-2343987
		WEIGHT -	RESTRICTED TO -		
		CUSTOMER DRAWING	SCALE 2:1	SHEET 1 OF 7	REV A2

THIS DRAWING IS UNPUBLISHED. RELEASED FOR PUBLICATION 20
 © COPYRIGHT 20 BY - ALL RIGHTS RESERVED.

REVISIONS					
P	LTR	DESCRIPTION	DATE	DWN	APVD
-		SEE SHEET 1	-	-	-

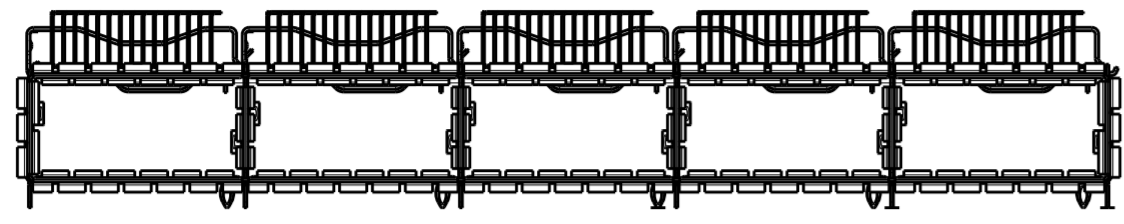

2343987-2
 UNMARKED DIMENSIONS SAME AS 2343987-1
 SCALE 3:2

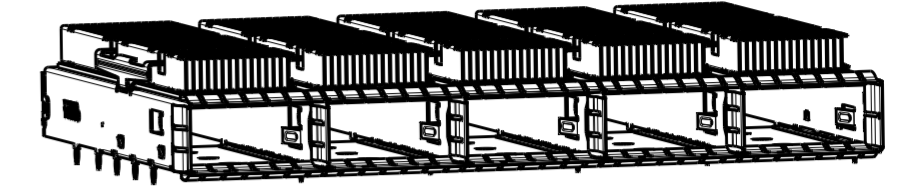
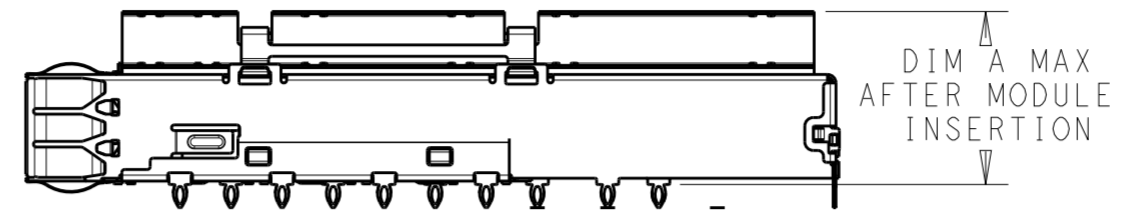

SCALE 1:1

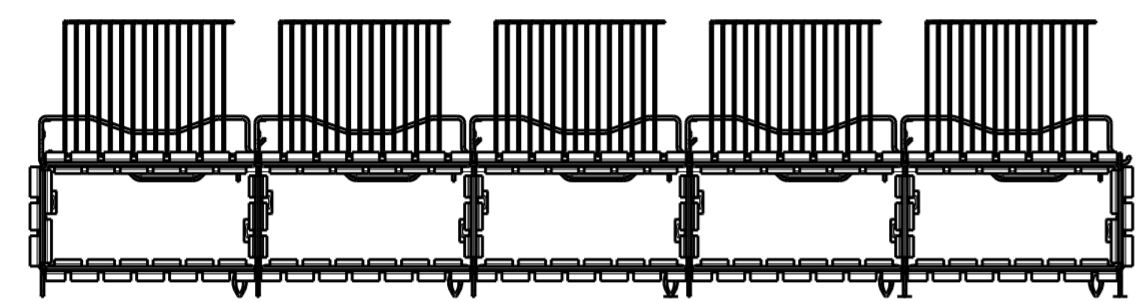

2343987-3
 UNMARKED DIMENSIONS SAME AS 2343987-1
 SCALE 3:2

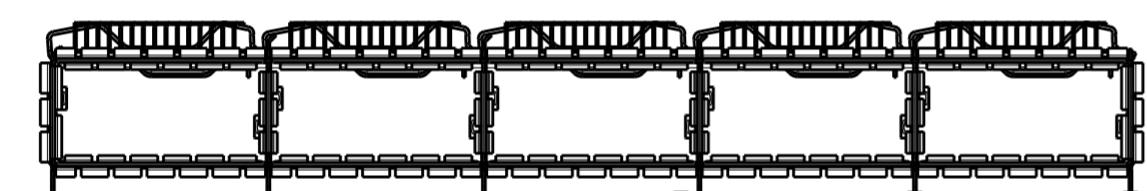
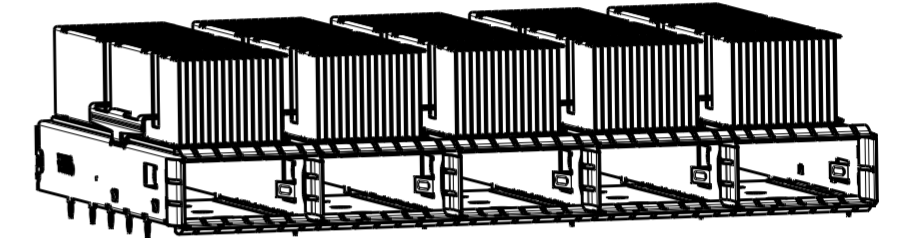
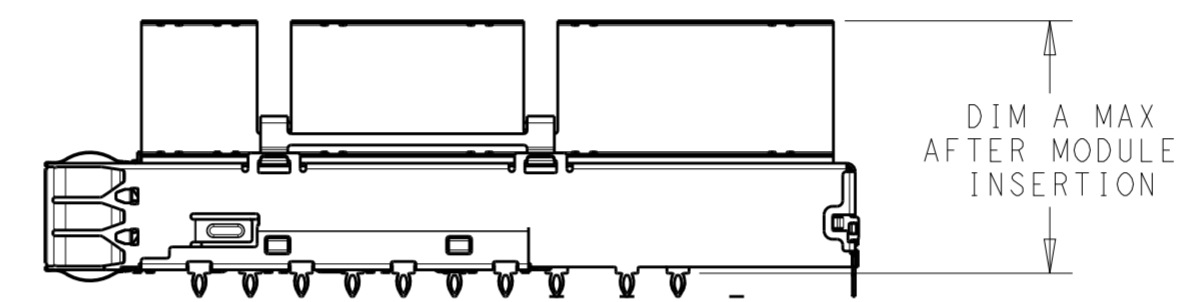

1-2343987-1 W/O REAR EONS
 DIMENSIONS SAME AS 2343987-1
 SCALE 3:2

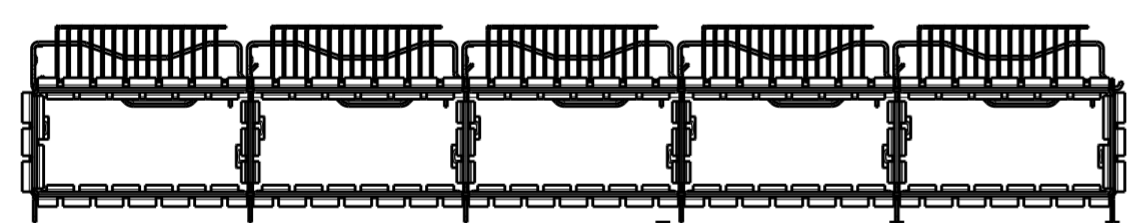
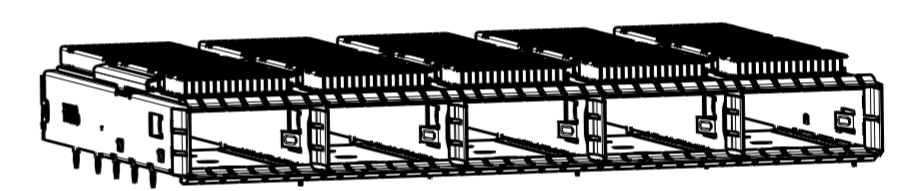
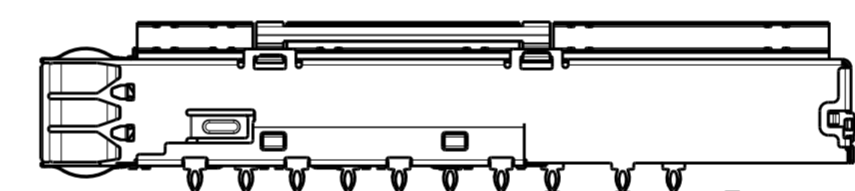

1-2343987-2 W/O REAR EONS
 DIMENSIONS SAME AS 2343987-2
 SCALE 3:2

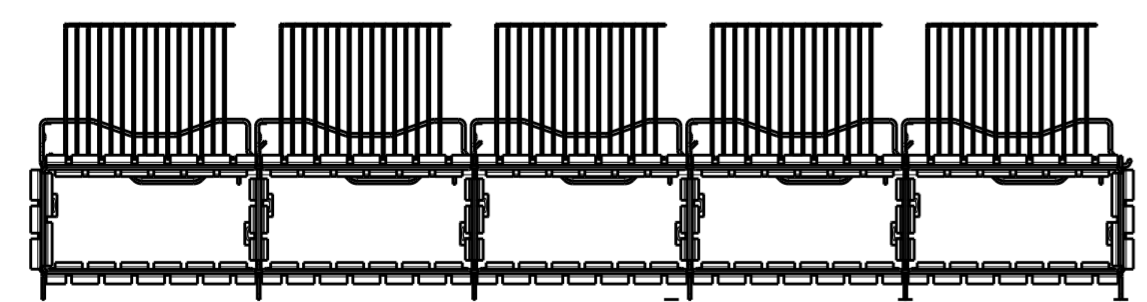
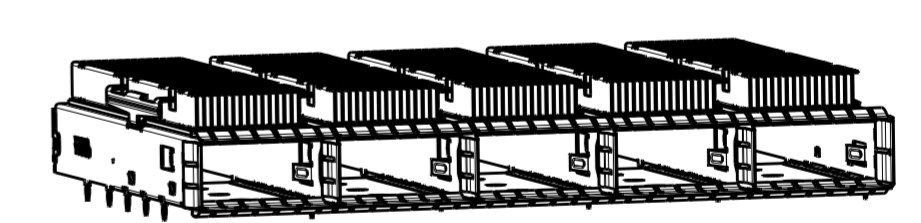
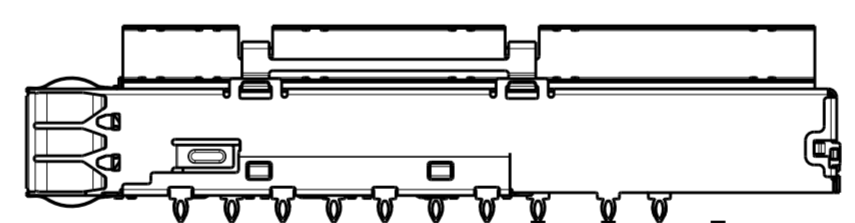

1-2343987-3 W/O REAR EONS
 DIMENSIONS SAME AS 2343987-3
 SCALE 3:2

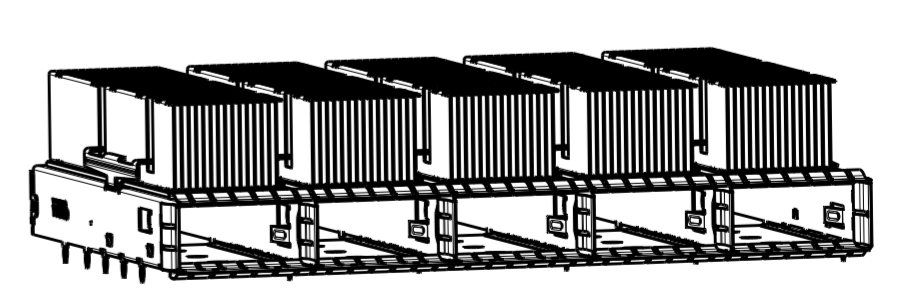
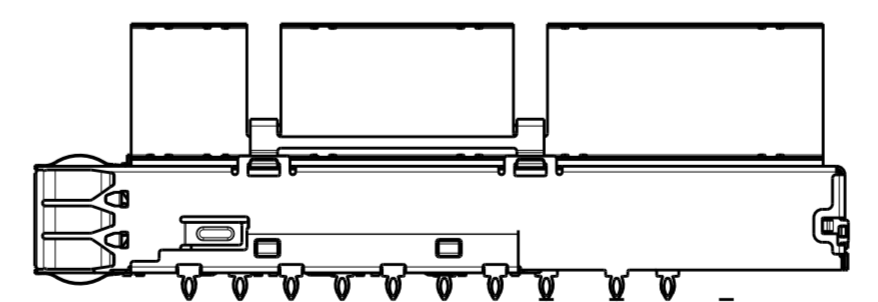

THIS DRAWING IS A CONTROLLED DOCUMENT.		DWN J. WANG 13SEP2018	TE Connectivity	
DIMENSIONS:		CHK S. HAN 13SEP2018		
mm	TOLERANCES UNLESS OTHERWISE SPECIFIED:	APVD S. HAN 13SEP2018	NAME CAGE ASSEMBLY WITH HEATSINK THRU BEZEL, 1X5, QSFPDD	
	0 PLC ±0.25 1 PLC ±0.25 2 PLC ±0.25 3 PLC ± 4 PLC ± ANGLES ± FINISH	PRODUCT SPEC -	SIZE A2	
MATERIAL	-	APPLICATION SPEC -	CAGE CODE -	DRAWING NO G-2343987
		WEIGHT -	RESTRICTED TO -	SCALE 2:1 SHEET 2 OF 7 REV A2
		CUSTOMER DRAWING		

THIS DRAWING IS UNPUBLISHED. RELEASED FOR PUBLICATION 20
 © COPYRIGHT 20 BY - ALL RIGHTS RESERVED.

REVISIONS				
P	LTR	DESCRIPTION	DATE	APVD
-		SEE SHEET 1	-	-

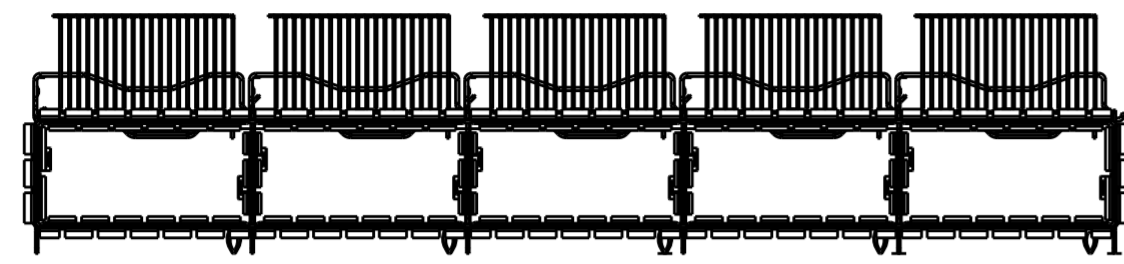

2343987-7 AS SHOWN
 SAME AS -3 EXCEPT HS
 SCALE 3:2

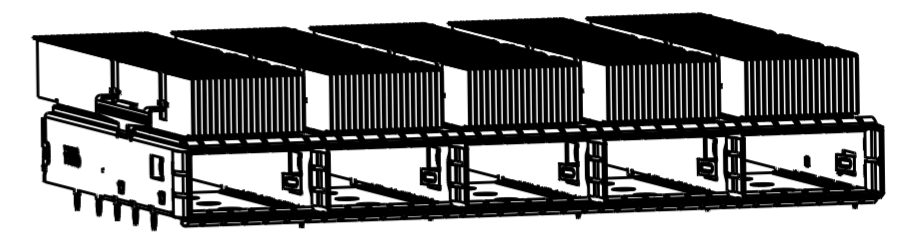
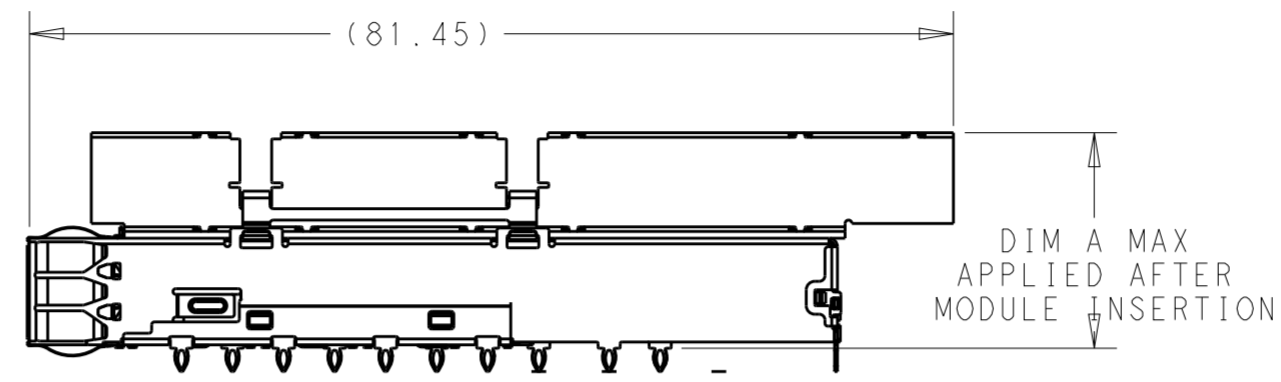

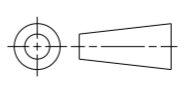
THIS DRAWING IS A CONTROLLED DOCUMENT.		DWN J. WANG 13SEP2018	 TE Connectivity	
DIMENSIONS:		CHK S. HAN 13SEP2018		
TOLERANCES UNLESS OTHERWISE SPECIFIED:		APVD S. HAN 13SEP2018		
mm	0 PLC ±0.25 1 PLC ±0.25 2 PLC ±0.25 3 PLC ± 4 PLC ±	PRODUCT SPEC -	NAME CAGE ASSEMBLY WITH HEATSINK THRU BEZEL, 1X5, QSFPDD	
	ANGLES ± FINISH ±	APPLICATION SPEC -	SIZE A2	CAGE CODE -
MATERIAL -		WEIGHT -	DRAWING NO. C-2343987	RESTRICTED TO -
		CUSTOMER DRAWING	SCALE 2:1	SHEET 3 OF 7
				REV A2

THIS DRAWING IS UNPUBLISHED. RELEASED FOR PUBLICATION 20
 © COPYRIGHT 20 BY - ALL RIGHTS RESERVED.

REVISIONS					
P	LTR	DESCRIPTION	DATE	DWN	APVD
-	-	SEE SHEET 1	-	-	-

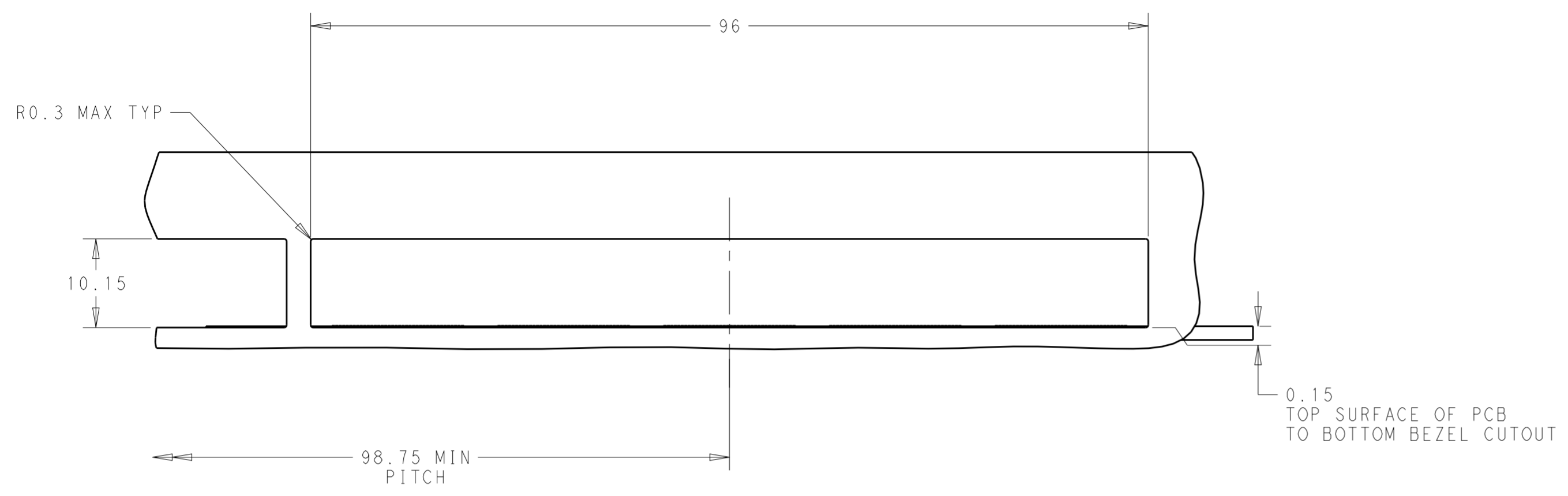

CAGE ASSEMBLY OMITTED FOR CLARITY

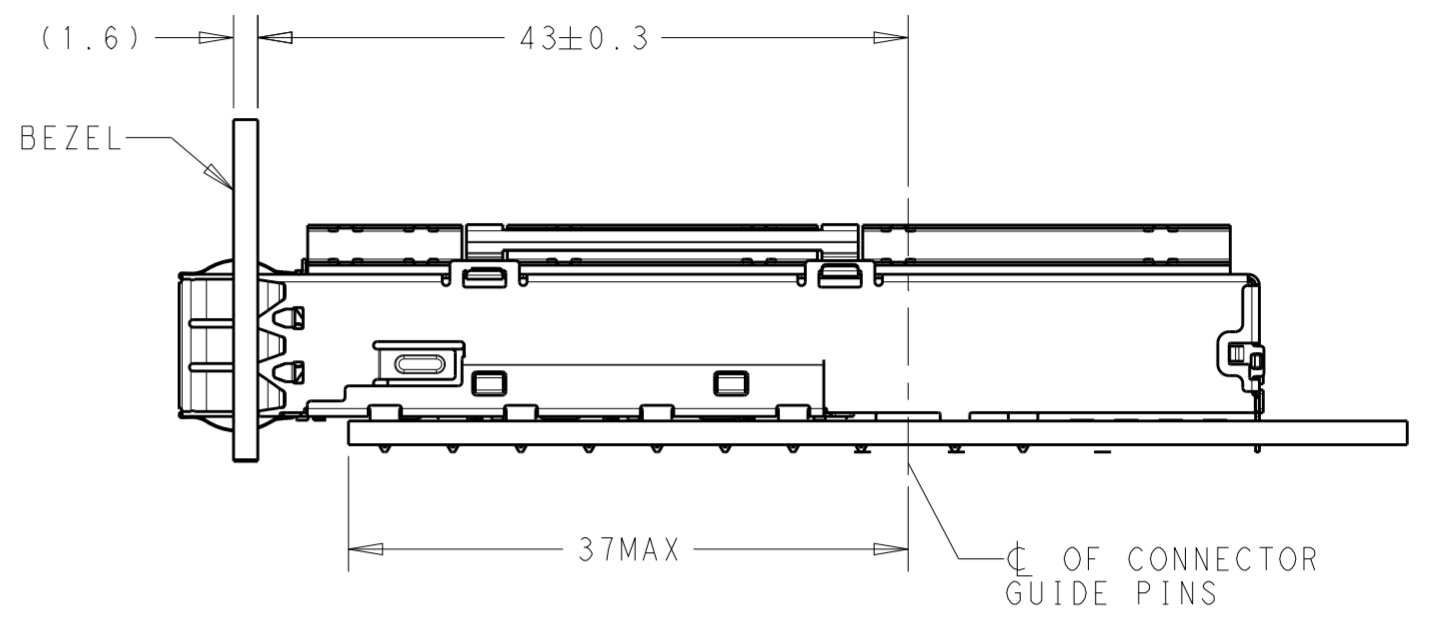

SINGLE SIDE MOUNTING

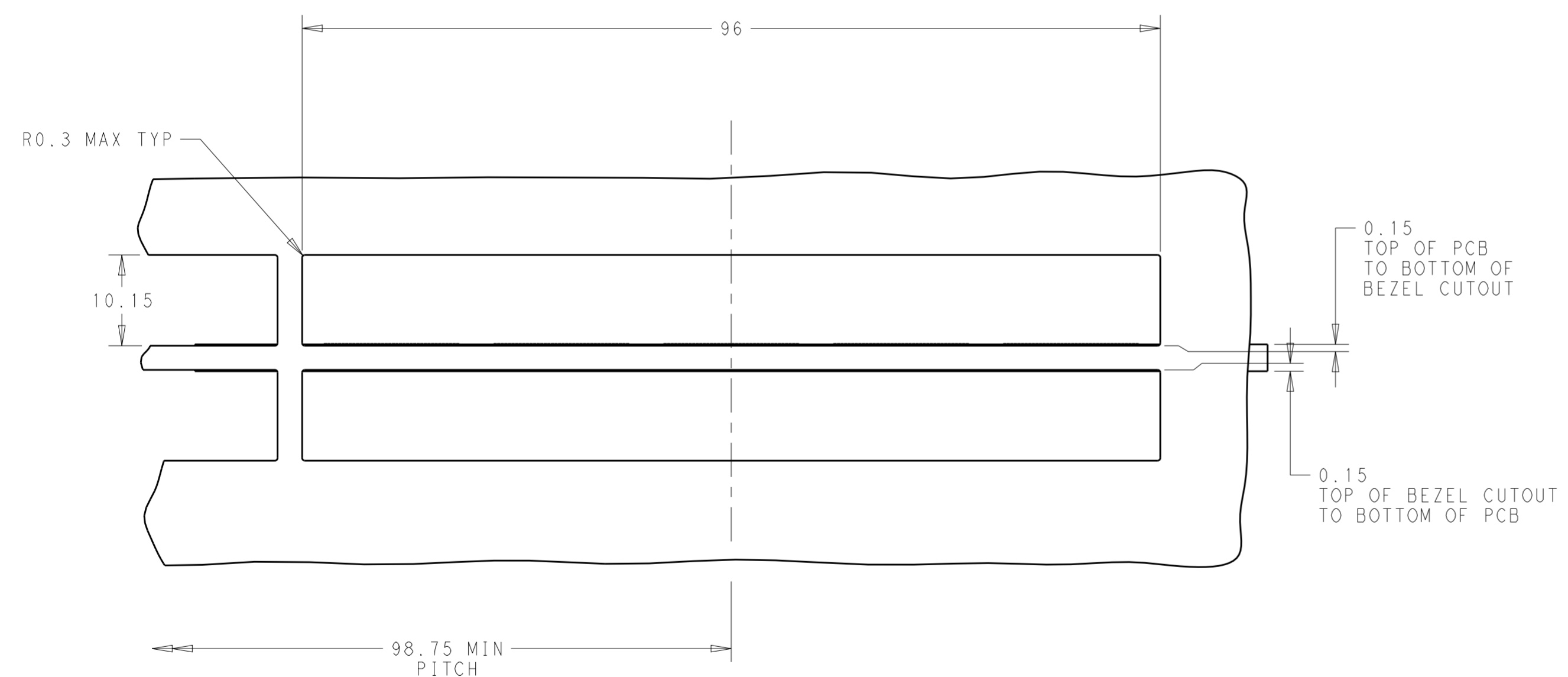

CAGE ASSEMBLY OMITTED FOR CLARITY

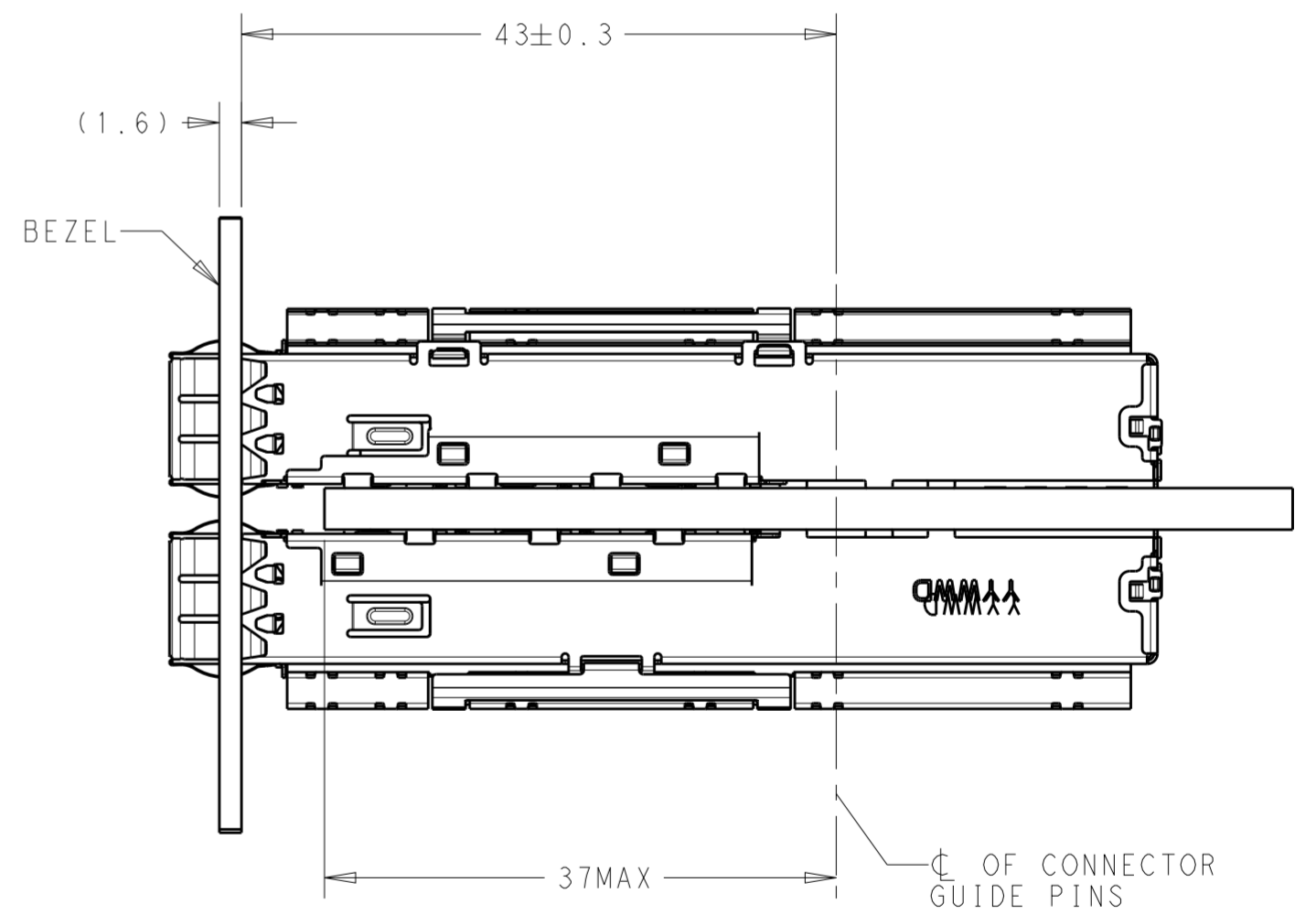

BELLY TO BELLY MOUNTING

THIS DRAWING IS A CONTROLLED DOCUMENT.		DWN J. WANG 13SEP2018	 TE Connectivity
DIMENSIONS:		CHK S. HAN 13SEP2018	
mm		APVD S. HAN 13SEP2018	
TOLERANCES UNLESS OTHERWISE SPECIFIED:		PRODUCT SPEC	NAME CAGE ASSEMBLY WITH HEATSINK THRU BEZEL, 1X5, QSFDD
0 PLC	±0.25	APPLICATION SPEC	SIZE A2
1 PLC	±0.25	WEIGHT	CAGE CODE -
2 PLC	±0.25	CUSTOMER DRAWING	DRAWING NO. C-2343987
3 PLC	±	SCALE 2:1	RESTRICTED TO -
4 PLC	±	SHEET 4 OF 7	REV A2
ANGLES	±		
FINISH	-		

THIS DRAWING IS UNPUBLISHED. RELEASED FOR PUBLICATION 20
 © COPYRIGHT 20 BY - ALL RIGHTS RESERVED.

REVISIONS				
P	LTR	DESCRIPTION	DATE	APVD
-	-	SEE SHEET 1	-	-

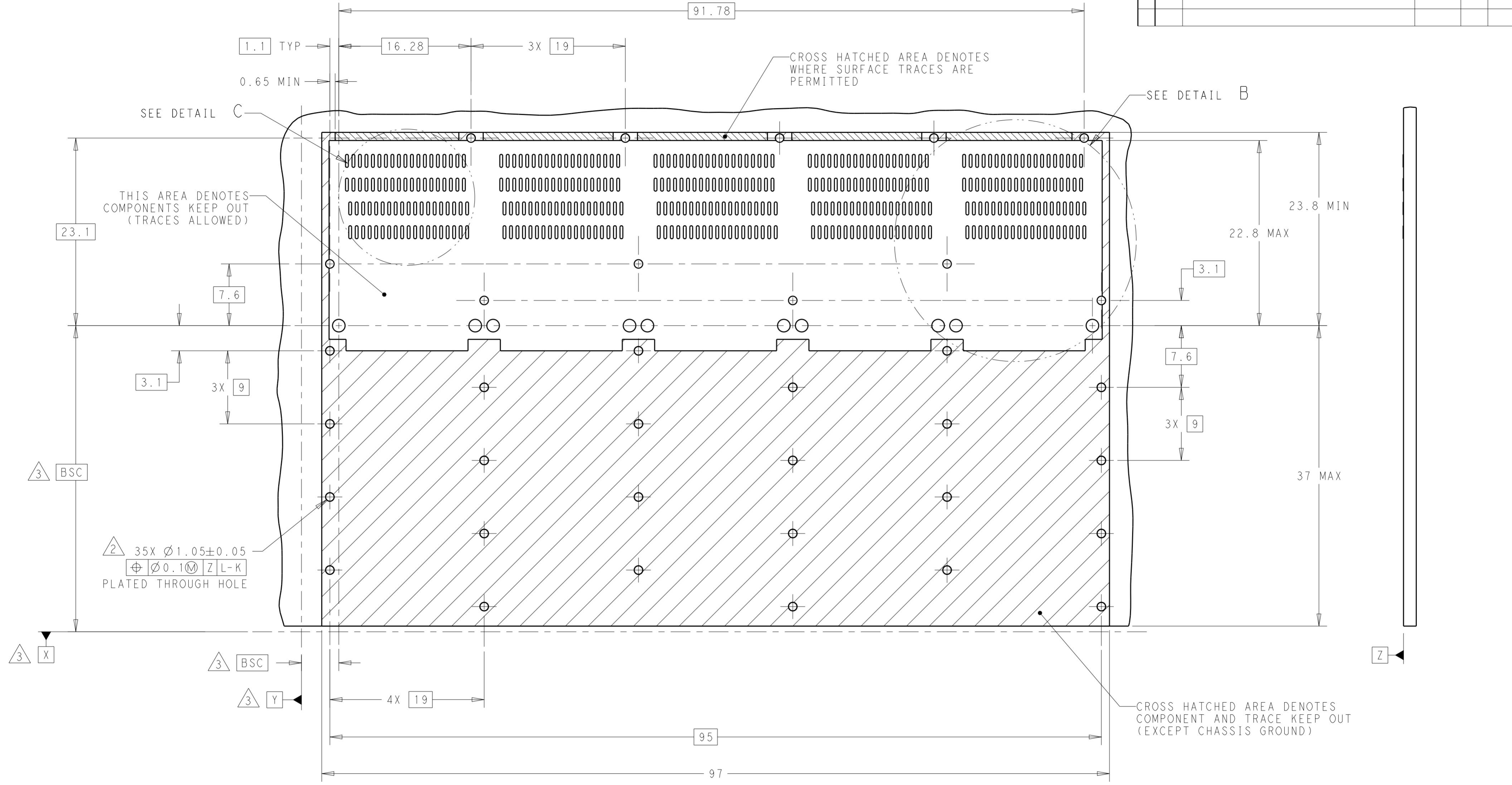

RECOMMENDED PCB LAYOUT
 SINGLE TYPE
 SCALE 3:1

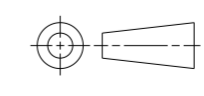
THIS DRAWING IS A CONTROLLED DOCUMENT.		DWN J. WANG 13SEP2018	 TE Connectivity
DIMENSIONS: mm		CHK S. HAN 13SEP2018	
		APVD S. HAN 13SEP2018	
TOLERANCES UNLESS OTHERWISE SPECIFIED:		PRODUCT SPEC	NAME CAGE ASSEMBLY WITH HEATSINK THRU BEZEL, 1X5, QSFDD
0 PLC	±0.25	APPLICATION SPEC	SIZE A2
1 PLC	±0.25	WEIGHT	CAGE CODE -
2 PLC	±0.25	CUSTOMER DRAWING	DRAWING NO C-2343987
3 PLC	±	SCALE 2:1	RESTRICTED TO -
4 PLC	±	SCALE 2:1	SHEET 5 OF 7
ANGLES	±	SCALE 2:1	REV A2
FINISH	-	SCALE 2:1	REV A2

THIS DRAWING IS UNPUBLISHED. RELEASED FOR PUBLICATION 20
 © COPYRIGHT 20 BY - ALL RIGHTS RESERVED.

REVISIONS				
P	LTR	DESCRIPTION	DATE	APVD
-	-	SEE SHEET 1	-	-

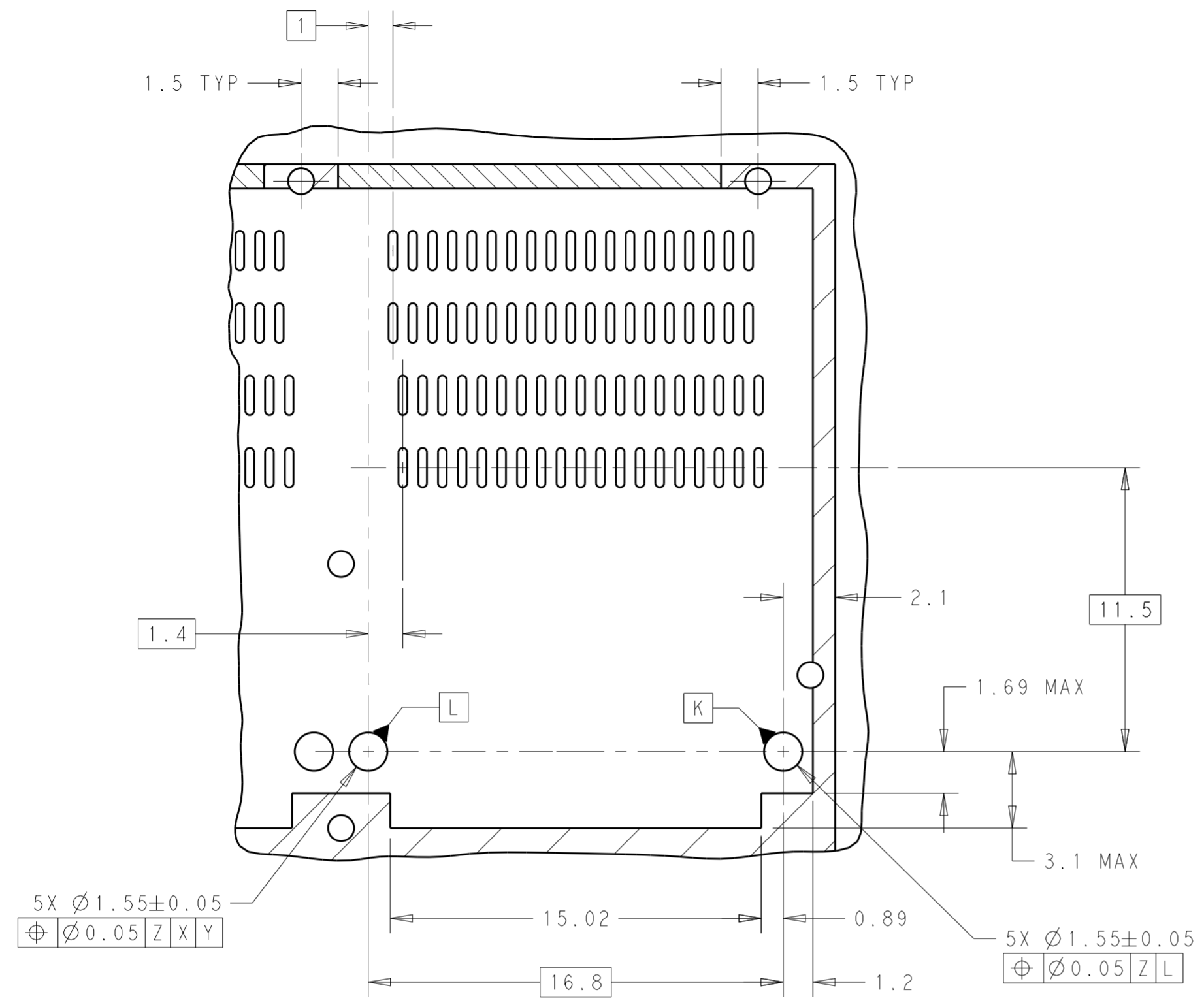

DETAIL B
 SCALE 5:1

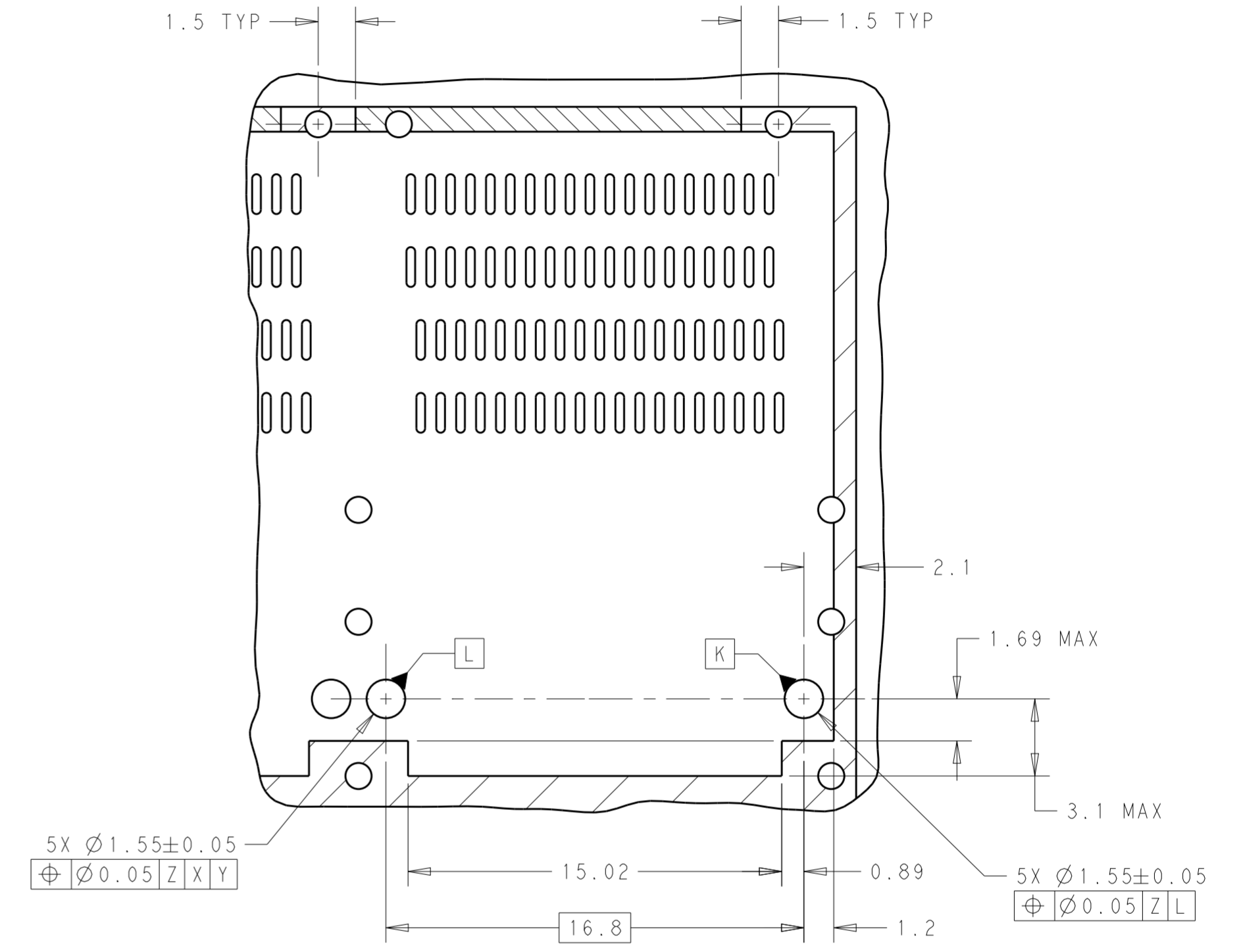

DETAIL D
 SCALE 5:1

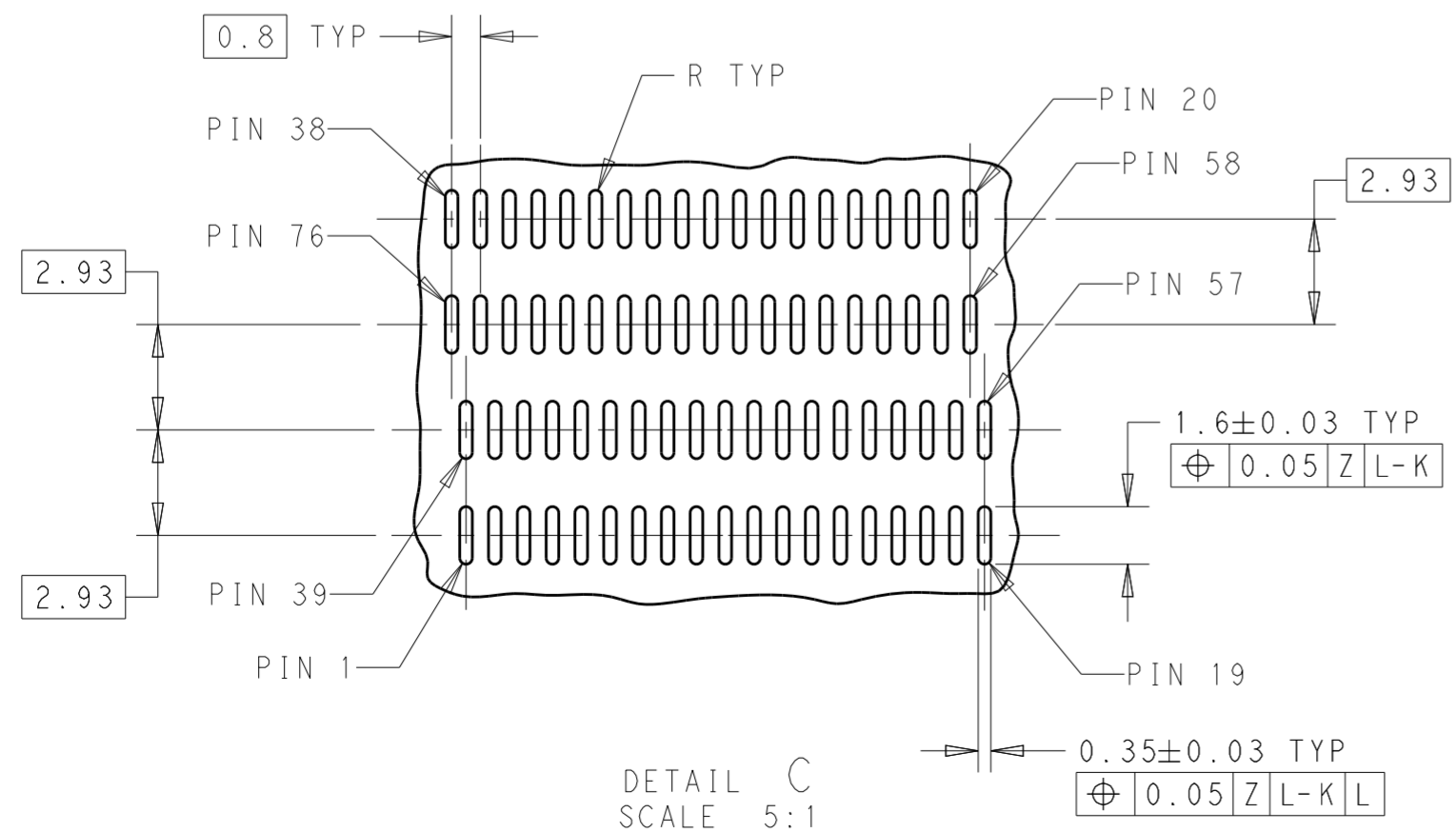

DETAIL C
 SCALE 5:1

THIS DRAWING IS A CONTROLLED DOCUMENT.		DWN J. WANG 13SEP2018	TE Connectivity	
DIMENSIONS: mm		CHK S. HAN 13SEP2018		
TOLERANCES UNLESS OTHERWISE SPECIFIED:		APVD S. HAN 13SEP2018	NAME CAGE ASSEMBLY WITH HEATSINK THRU BEZEL, 1X5, QSPFDD	
0 PLC ±0.25		PRODUCT SPEC	SIZE A2	
1 PLC ±0.25		APPLICATION SPEC	CAGE CODE -	
2 PLC ±0.25		WEIGHT	DRAWING NO C-2343987	
3 PLC ±		CUSTOMER DRAWING	RESTRICTED TO -	
4 PLC ±		SCALE 2:1	SHEET 7 OF 7	
ANGLES ±		REV A2		
FINISH ±				