

NOTES: UNLESS OTHERWISE SPECIFIED:

1. INTERPRET DRAWING PER ASME Y14.5M-1994.
2. MATERIAL: ALUMUNUM ADC -10 CASTING ALLOY
3. FINAL PRODUCT FREE OF LUBRICATING SUBSTANCE.
4. PART SHALL BE DIECAST, MOUNTING SURFACE TO BE FLY CUT IN ONE PASS.
5. ALL EXPOSED EDGES MUST MEET THE SAFE HANDLING REQUIREMENTS BY UL 1439.
6. THIS PART/ASSEMBLY MUST COMPLY WITH:
 - A) IBM SPECIFICATION 53P6233-COMPLIANCE REQUIREMENTS OF EUROPEAN UNION DIRECTIVE ON THE RESTRICTION OF THE USE OF CERTAIN HAZARDOUS SUBSTANCES IN ELECTRICAL AND ELECTRONICS EQUIPMENT FOR IBM PRODUCTS AND
 - B) IBM SPECIFICATION 46G3772-IBM ENVIROMENTAL REQUIREMENTS FOR MATERIALS, PARTS AND PRODUCTS. SUPPLIER MUST COMPLETE AND FORWARD AND ECP QUESTIONAIRE TO IBM PROCUREMENT ENGINEERING AS PART OF THE FIRST ARTICLE INSPECTION (FAI) PROCESS.
7. RoHS COMPLIANCE AND CERTIFIED.

OBSOLETE

CUSTOMER DRAWING
SPECIFICATIONS ARE SUBJECT TO CHANGE WITHOUT NOTICE

REVISION INFO	REV.
PRELIMINARY ERN #111661 BM 9-14-06 APP'D: VK 9-14-06	I
RELEASED ERN #: 11669 BM 9-22-06 APP'D: VK 9-22-06	A
RELEASED ECO-06-027162 ETAO 11-17-06 APP'D: V.K 11-17-07	B
RELEASED ECO-06-027485 BM 11-22-06 APP'D: V.K 11-22-06	C
RELEASED ECO-07-000246 BM 1-2-07 APP'D: VK 1-4-07	D
UNRELEASED ECO-07-02114 ETAO 9-7-07 APP'D: BP 9-7-07	E

DO NOT SCALE	TE TE Connectivity		Norwood, Massachusetts 02062	
	UNLESS OTHERWISE SPECIFIED TOLERANCES ARE:	DRAWN BY: BM	DATE: 9-14-06	MATERIAL: SEE NOTE 2
	X, X ± .25 X, XX ± .15 X, XXX ± .051 ANGLES ± 1°	ENGINEER: V. KHEIL	DATE: 9-14-06	FINISH:
		FILENAME 1963054C	PROJECT PRO-E	

CONFIDENTIAL PROPERTY OF TE CONNECTIVITY. NOT TO BE DISCLOSED TO OTHERS, REPRODUCED OR USED FOR ANY PURPOSES EXCEPT AS AUTHORIZED IN WRITING BY AN AUTHORIZED OFFICIAL OF TE CONNECTIVITY. MUST BE RETURNED TO TE CONNECTIVITY ON DEMAND, ON COMPLETION OF ORDERS OR OTHER PURPOSES FOR WHICH LENT.		TITLE: CUSTOMER DRAWING, HEATSINK, MDA-EZ	
		DIMENSIONS ARE IN: MILLIMETERS	SCALE: 1:1
THIRD ANGLE PROJECTION	SIZE B	DWG. NO.: C-1963054	REV. E1

OBSOLETE

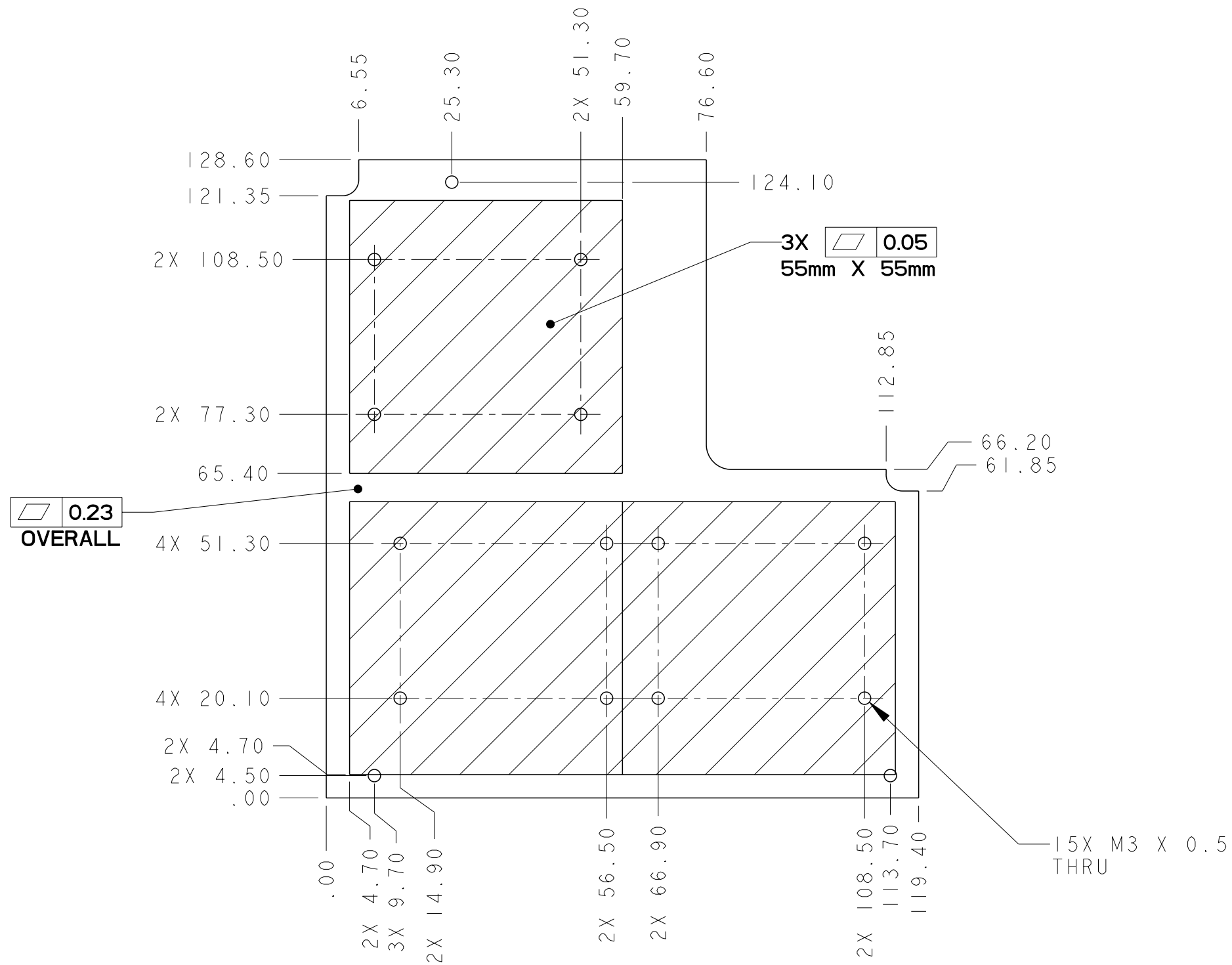

REVISION INFO	REV.
RELEASED	
SEE SHEET 1	

DO NOT SCALE	TE TE Connectivity		Norwood, Massachusetts 02062	
	UNLESS OTHERWISE SPECIFIED TOLERANCES ARE:	DRAWN BY: BM	DATE: 9-14-06	MATERIAL: SEE SHEET 1
	SEE SHEET 1	ENGINEER: V. KHEIL	DATE: 9-14-06	FINISH:
		FILENAME 1963054C	PROJECT PRO-E	

CONFIDENTIAL PROPERTY OF TE CONNECTIVITY. NOT TO BE DISCLOSED TO OTHERS, REPRODUCED OR USED FOR ANY PURPOSES EXCEPT AS AUTHORIZED IN WRITING BY AN AUTHORIZED OFFICIAL OF TE CONNECTIVITY. MUST BE RETURNED TO TE CONNECTIVITY ON DEMAND, ON COMPLETION OF ORDERS OR OTHER PURPOSES FOR WHICH LENT.		TITLE: HEATSINK, MDA-EZ		
		DIMENSIONS ARE IN: MILLIMETERS	SCALE: 1:1	TE PART NO.: SEE SHEET 1
THIRD ANGLE PROJECTION		SIZE B	DWG. NO.: 1963054C	REV. E1