

THIS DRAWING IS UNPUBLISHED. RELEASED FOR PUBLICATION  
 © COPYRIGHT - By - ALL RIGHTS RESERVED.

REVISIONS				
P	LTR	DESCRIPTION	DATE	APVD
P3		REVISED PER ECR-19-013075	10SEP2019	BDA SW

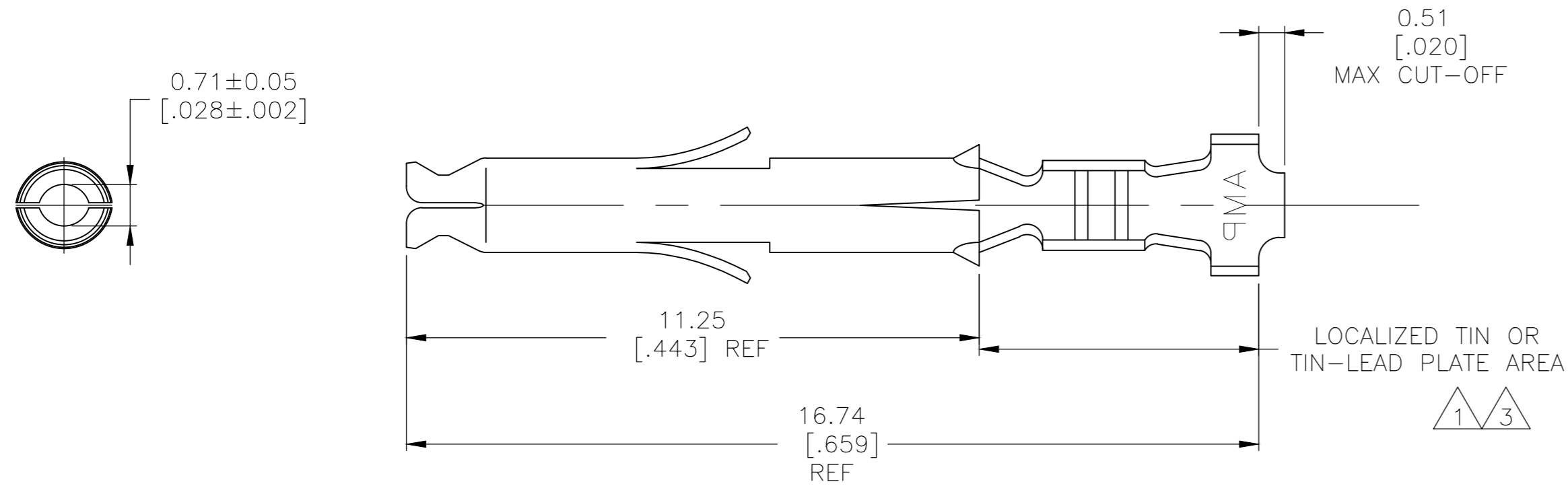

- 1. 0.00076 [.000030] MIN GOLD IN LOCALIZED GOLD PLATE AREA AND 0.00254 [.000100] MIN BRIGHT TIN-LEAD IN LOCALIZED TIN-LEAD PLATE AREA OVER 0.0013 [.000050] MIN NICKEL.
- 2. WIRE RANGE: 0.5-0.15 mm<sup>2</sup>(30-26 AWG)
- 3. 0.00076 [.000030] MIN GOLD IN LOCALIZED GOLD PLATE AREA AND 0.00254 [.000100] MIN MATTE TIN IN LOCALIZED TIN PLATE AREA OVER 0.0013 [.000050] MIN NICKEL.
- 4. SUPERSEDED BY 1-770834-1

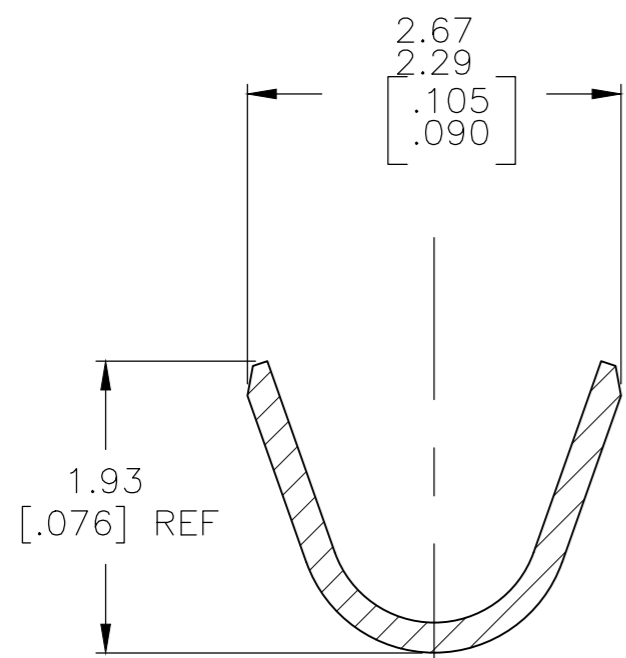
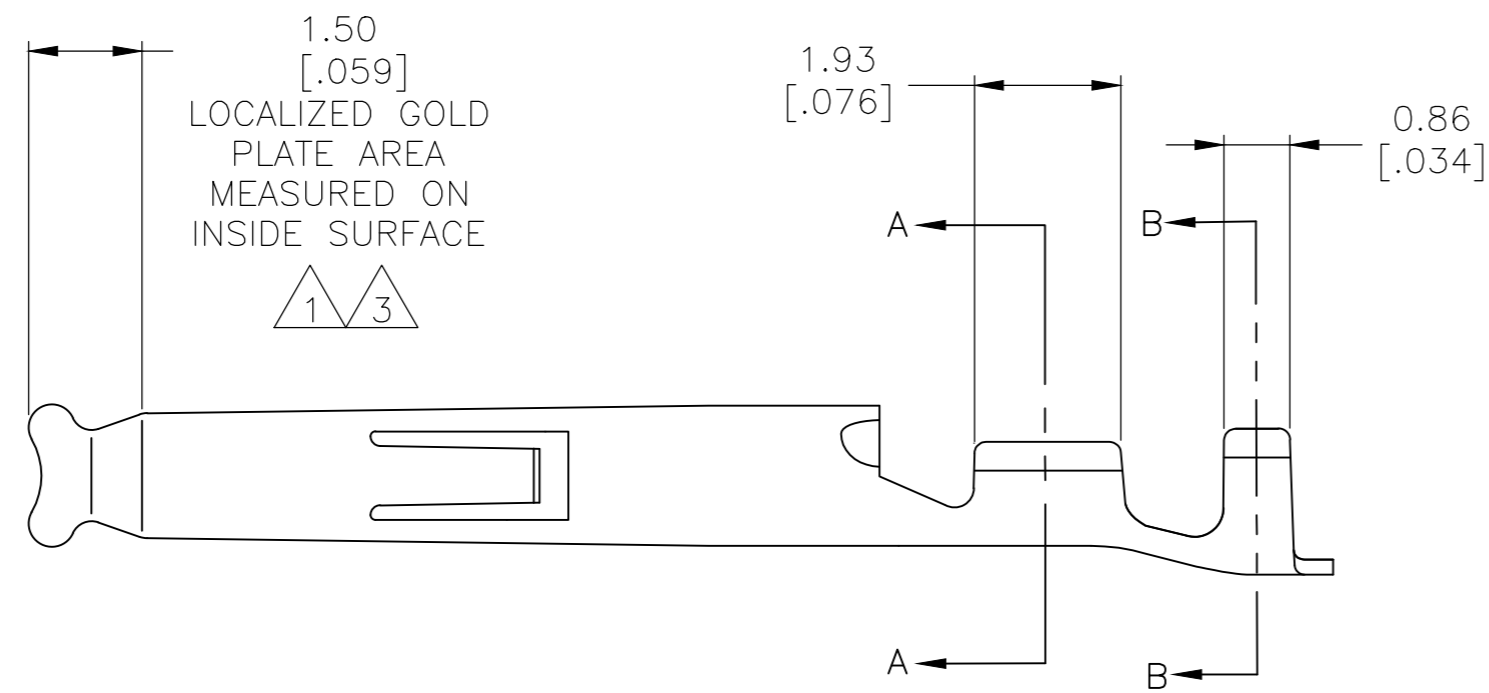

SECTION B-B  
SCALE 20:1

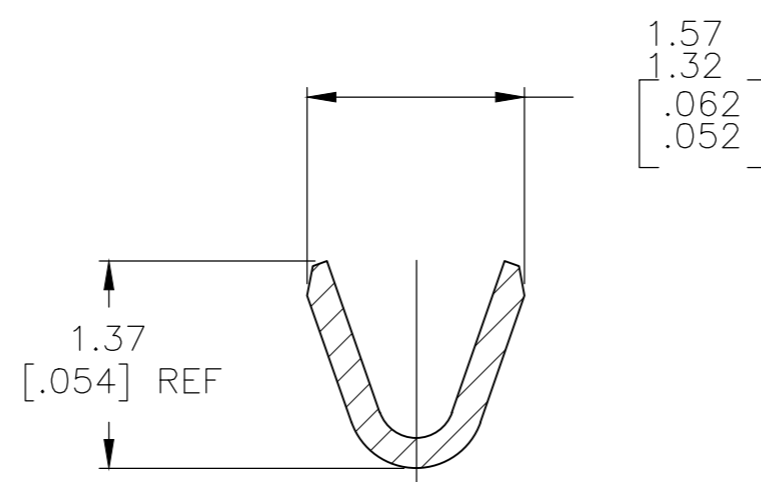

SECTION A-A  
SCALE 20:1

FINISH	MATERIAL	PART NUMBER
3	0.20 [.008] PH BRZ	1-770834-1
3	0.20 [.008] BRASS	1-770834-0
1	0.20 [.008] PH BRZ	<del>770834-6</del>
PRE-TIN	0.20 [.008] PH BRZ	770834-4
1	0.20 [.008] BRASS	770834-3
PRE-TIN	0.20 [.008] BRASS	770834-1

THIS DRAWING IS A CONTROLLED DOCUMENT.		DWN S. HOOVER 17OCT02	<b>STE</b> TE Connectivity	
DIMENSIONS: mm [INCHES]		CHK C. JONES 17OCT02		
TOLERANCES UNLESS OTHERWISE SPECIFIED:		APVD C. JONES 17OCT02	NAME	
0 PLC ± -	1 PLC ± -	PRODUCT SPEC	SOCKET, MINI UNIVERSAL MATE-N-LOK(TM)	
2 PLC ± -	3 PLC ± 0.15[.006]	APPLICATION SPEC	SIZE A2	CAGE CODE 00779
4 PLC ± -	ANGLES ± 1°	WEIGHT	DRAWING NO C=770834	RESTRICTED TO -
MATERIAL -	FINISH -	CUSTOMER DRAWING	SCALE 10:1	SHEET 1 of 1
			REV P3	