

THIS COPY IS PROVIDED ON A RESTRICTED BASIS AND IS NOT TO BE USED IN ANY WAY DETRIMENTAL TO THE INTERESTS OF PANDUIT CORP.

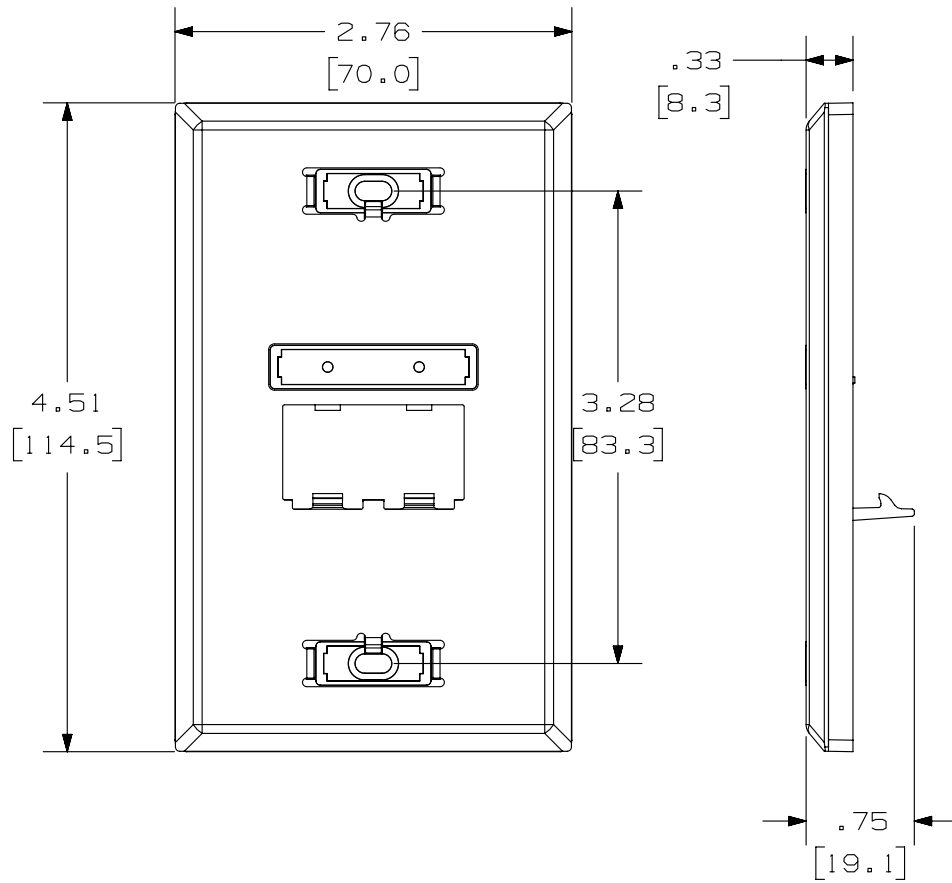

PANDUIT P/N	WEIGHT
UICFP2S	1.47 LB/10 PCS (668.3g/10 PCS)

NOTES:

- SEE CURRENT CATALOG FOR ADDITIONAL PART NUMBER SUFFIXES TO INDICATE COLOR AND OR PACKAGE QUANTITY.
- SEE CATALOG FOR COMPLETE LIST OF PARTS APPLICABLE FOR USE WITH THIS PART.
- DIMENSIONS IN PARENTHESES ARE IN METRIC.
- PART INCLUDES:
  - 1- FACEPLATE
  - 2- MOUNTING SCREWS
  - 1- CLEAR SCREW COVER
  - 1- COLOR COORDINATED SCREW COVER
  - 1- CLEAR LABEL COVER

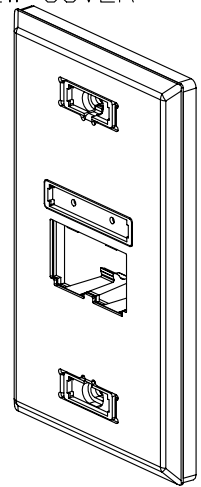

PART NUMBER		UICFP2S	
TITLE			
MINI-COM ULTIMATE ID 2 POSITION STAINLESS STEEL FACEPLATE			
CUSTOMER DRAWING			
ITEM REVISION NAME		M02237AA/01	
DATASET FILE NAME		M02237AA_DC/01B	
UNLESS OTHERWISE SPECIFIED, DIMENSIONAL TOLERANCES ARE: IN (mm)		MATERIAL:	
.x ± .xx ± .03 (.8)		FACEPLATE: 304 STAINLESS STEEL	
.xxx ± .010 (.3)		BACKING: ABS	
ANGLES ±		DRAWING NUMBER:	
THIRD ANGLE PROJECTION		02237-07	
DRAWN BY	DATE	CHK	SCALE
JSP	4-4-07	JCO	NONE
SHT 1 OF 1			SIZE
			A

1	5-20-14	BJN	JSP	MMR	REVISED & REDRAWN PREVIOUS REVISIONS REMVD FOR CLARITY	02237-07
REV	DATE	BY	CHK	APR	DESCRIPTION	ECN

D10100DA/14