

## 6-Ω, Low Voltage, Dual SPST Analog Switch

### DESCRIPTION

The DG2737, DG2738 and DG2739 are high performance, low on-resistance analog switches of dual SPST configuration.

Built on Vishay Siliconix's sub-micro CMOS technology, the DG2737, DG2738, DG2739 achieve switch on-resistance of 6 Ω at 3 V V+. Its -3 dB bandwidth is typically 720 MHz.

It can switch signals with amplitudes of up to V<sub>CC</sub> to be transmitted in either direction.

Combining low power, high speed, low on-resistance and small physical size, the DG2737, DG2738, DG2739 are ideal for portable and battery powered applications requiring high performance and efficient use of board space.

The DG2737, DG2738, DG2739 come in a small miniQFN8 lead package (1.4 x 1.4 x 0.55 mm). As a committed partner to the community and the environment, Vishay Siliconix manufactures this product with the lead (Pb)-free device terminations and is 100 % RoHS compliant.

### FEATURES

- Voltage range: 2.3 V to 4.3 V
- Low on-resistance: 6 Ω typ. at 3 V
- -48 dB crosstalk at 240 MHz
- Low power consumption
- Ultra small miniQFN8 package of 1.4 x 1.4 x 0.55 mm
- > 300 mA latch up current per JEDEC78
- Switch exceeds 5 kV ESD/HBM

**RoHS**  
COMPLIANT

### FUNCTIONAL BLOCK DIAGRAM AND PIN CONFIGURATION

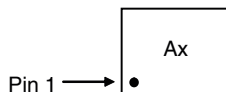
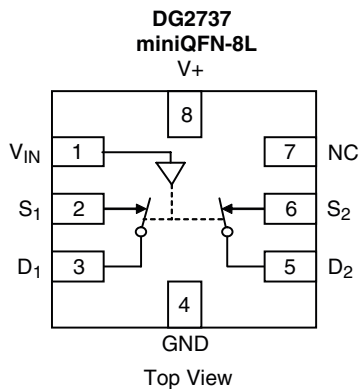

Device Marking: Ax for DG2737  
x = Date/Lot Traceability Code

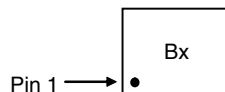
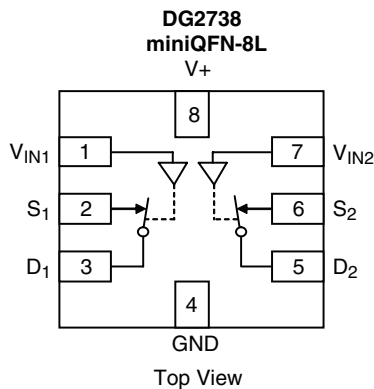

Device Marking: Bx for DG2738  
x = Date/Lot Traceability Code

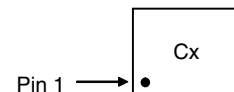
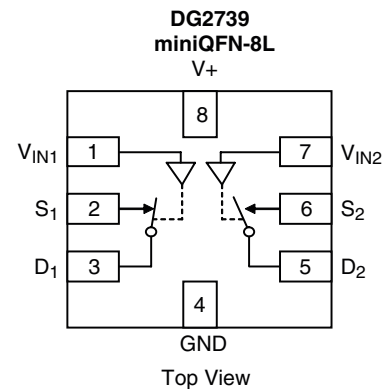

Device Marking: Cx for DG2739  
x = Date/Lot Traceability Code

TRUTH TABLE 1			
Input	Logic	DG2737	
		S <sub>1</sub> and D <sub>1</sub>	S <sub>2</sub> and D <sub>2</sub>
V <sub>IN</sub>	Low	ON	ON
	High	OFF	OFF

TRUTH TABLE 2					
Input	Logic	DG2738		DG2739	
		S <sub>1</sub> and D <sub>1</sub>	S <sub>2</sub> and D <sub>2</sub>	S <sub>1</sub> and D <sub>1</sub>	S <sub>2</sub> and D <sub>2</sub>
V <sub>IN1</sub>	Low	ON	X	ON	X
	High	OFF	X	OFF	X
V <sub>IN2</sub>	Low	X	ON	X	OFF
	High	X	OFF	X	ON

ORDERING INFORMATION		
Temp. Range	Package	Part Number
- 40 °C to 85°C	miniQFN-8L	DG2737DN-T1-E4 DG2738DN-T1-E4 DG2739DN-T1-E4

ABSOLUTE MAXIMUM RATINGS T <sub>A</sub> = 25 °C, unless otherwise noted			
Parameter		Limit	Unit
Reference to GND	V+	- 0.3 to 5.0	V
	V <sub>IN</sub> , D, S <sup>a</sup>	- 0.3 to (V+ + 0.3)	
Current (Any terminal except D or S)		30	mA
Continuous Current (D or S)		± 300	
Peak Current (Pulsed at 1 ms, 10 % Duty Cycle)		± 500	
Storage Temperature (D Suffix)		- 65 to 150	°C
Power Dissipation (Packages) <sup>b</sup>	miniQFN-8L <sup>c</sup>	190	mW

Notes:

- a. Signals on V<sub>IN</sub>, D, or S exceeding V+ will be clamped by internal diodes. Limit forward diode current to maximum current ratings.
- b. All leads welded or soldered to PC board.
- c. Derate 2.4 mW/°C above 70 °C.

SPECIFICATIONS V+ = 3 V							
Parameter	Symbol	Test Conditions Unless Otherwise Specified V+ = 3 V, V <sub>IN</sub> = 0.4 V or 1.4 V <sup>e</sup>	Temp. <sup>a</sup>	Limits - 40 °C to 85 °C			Unit
				Min. <sup>b</sup>	Typ. <sup>c</sup>	Max. <sup>b</sup>	
<b>Analog Switch</b>							
Analog Signal Range <sup>d</sup>	V <sub>analog</sub>	R <sub>ON</sub>	Full	0		V+	V
On-Resistance	R <sub>ON</sub>	V+ = 3 V, I <sub>S</sub> = 8 mA, V <sub>D</sub> = 0.4 V	Room		6	8	Ω
			Full			9	
R <sub>ON</sub> Match <sup>d</sup>	ΔR <sub>ON</sub>	V+ = 3 V, I <sub>S</sub> = 8 mA, V <sub>D</sub> = 0.4 V	Room		0.1	0.5	
R <sub>ON</sub> Flatness <sup>d</sup>	R <sub>ON</sub> Flatness	V+ = 3 V, I <sub>S</sub> = 8 mA, V <sub>D</sub> = 0 V, 1 V	Room		2.6	4	



SPECIFICATIONS $V_+ = 3\text{ V}$								
Parameter	Symbol	Test Conditions Unless Otherwise Specified $V_+ = 3\text{ V}$ , $V_{IN} = 0.4\text{ V}$ or $1.4\text{ V}^e$	Temp. <sup>a</sup>	Limits - 40 °C to 85 °C			Unit	
				Min. <sup>b</sup>	Typ. <sup>c</sup>	Max. <sup>b</sup>		
<b>Analog Switch</b>								
Switch Off Leakage Current	$I_{S(off)}$	$V_+ = 4.3\text{ V}$ , $V_S = 0.3\text{ V}/3.3\text{ V}$ , $V_D = 3.3\text{ V}/0.3\text{ V}$	Room	- 10		10	nA	
			Full	- 100		100		
	$I_{D(off)}$		Room	- 10		10		
			Full	- 100		100		
Channel-On Leakage Current	$I_{D(on)}$	$V_+ = 4.3\text{ V}$ , $V_S = V_D = 4\text{ V}/0.3\text{ V}$	Room	- 10		10		
			Full	- 100		100		
<b>Digital Control</b>								
Input High Voltage	$V_{INH}$	$V_+ = 2.3\text{ V}$ to $4.3\text{ V}$	Full	1.3			V	
Input Low Voltage	$V_{INL}$		Full			0.5		
Input Current	$I_{INL}$ or $I_{INH}$	$V_{IN} = 0$ or $V_+$	Full	- 1		1	$\mu\text{A}$	
<b>Dynamic Characteristics</b>								
Turn-On Time <sup>e</sup>	$t_{ON}$	$V_+ = 2.3\text{ V}$ to $3.6\text{ V}$ , $V_{NO}$ or $V_S = 1.5\text{ V}$ , $R_L = 50\ \Omega$ , $C_L = 35\text{ pF}$	Room		23	60	ns	
			Full			70		
Turn-Off Time <sup>e</sup>	$t_{OFF}$		Room		13	50		
			Full			60		
Break-Before-Make Time	$t_{BBM}$	$V_+ = 2.3\text{ V}$ to $4.3\text{ V}$	Room		6		ns	
			Full	1				
Charge Injection <sup>d</sup>	Q	$C_L = 1\text{ nF}$ , $R_{GEN} = 0\ \Omega$ , $V_{GEN} = 0\text{ V}$	Room		10.4		pC	
Off-Isolation <sup>d</sup>	$O_{IRR}$	$R_L = 50\ \Omega$ , $C_L = 5\text{ pF}$ , $f = 1\text{ MHz}$ $R_L = 50\ \Omega$ , $C_L = 5\text{ pF}$ , $f = 10\text{ MHz}$ $R_L = 50\ \Omega$ , $C_L = 5\text{ pF}$ , $f = 240\text{ MHz}$	Room		- 79		dB	
					- 59			
					- 28			
Crosstalk <sup>d</sup>	$X_{TALK}$		$R_L = 50\ \Omega$ , $C_L = 5\text{ pF}$ , $f = 1\text{ MHz}$ $R_L = 50\ \Omega$ , $C_L = 5\text{ pF}$ , $f = 10\text{ MHz}$ $R_L = 50\ \Omega$ , $C_L = 5\text{ pF}$ , $f = 240\text{ MHz}$	Room		- 109		
						- 99		
						- 48		
3 dB bandwidth <sup>d</sup>		$R_L = 50\ \Omega$ , $C_L = 5\text{ pF}$		Room		720		MHz
Channel to Channel skew <sup>d</sup>		$R_L = 50\ \Omega$ , $C_L = 5\text{ pF}$		Room		25		ps
Skew of Opposite Transitions of the Same Output <sup>d</sup>					20			
Total Jitter <sup>d</sup>			200					
Source Off Capacitance <sup>d</sup>	$C_{S(off)}$	$f = 1\text{ MHz}$ , $V_S = 0\text{ V}$	Room		4.4		pF	
Drain Off Capacitance <sup>d</sup>	$C_{D(off)}$	$f = 1\text{ MHz}$ , $V_D = 0\text{ V}$	Room		3.8			
Drain On Capacitance <sup>d</sup>	$C_{D(on)}$	$f = 1\text{ MHz}$ , $V_D = V_S = 0\text{ V}$	Room		10			
Control Pin Capacitance <sup>d</sup>	$C_{IN}$	$f = 1\text{ MHz}$	Room		8.3			
<b>Power Supply</b>								
Power Supply Range	$V_+$			2.3		4.3	V	
Power Supply Current	$I_+$	$V_{IN} = 0$ or $V_+$	Full			1.0	$\mu\text{A}$	

Notes:

- a. Room = 25 °C, Full = as determined by the operating suffix.
- b. The algebraic convention whereby the most negative value is a minimum and the most positive a maximum, is used in this data sheet.
- c. Typical values are for design aid only, not guaranteed nor subject to production testing.
- d. Guarantee by design, not subjected to production test.
- e.  $V_{IN}$  = input voltage to perform proper function.

Stresses beyond those listed under "Absolute Maximum Ratings" may cause permanent damage to the device. These are stress ratings only, and functional operation of the device at these or any other conditions beyond those indicated in the operational sections of the specifications is not implied. Exposure to absolute maximum rating conditions for extended periods may affect device reliability.

**TYPICAL CHARACTERISTICS** 25 °C, unless otherwise noted

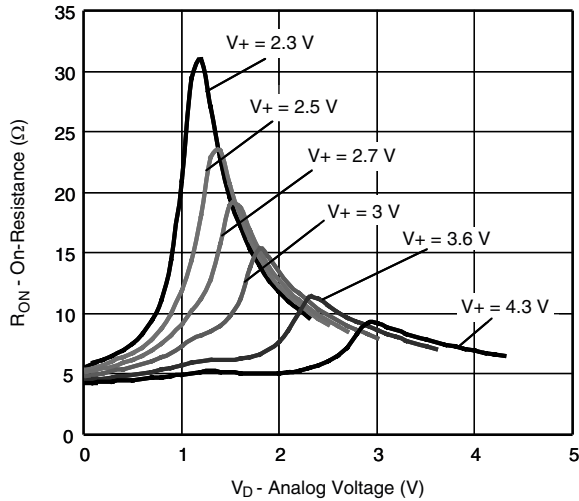

**RON vs. VD and Supply Voltage**

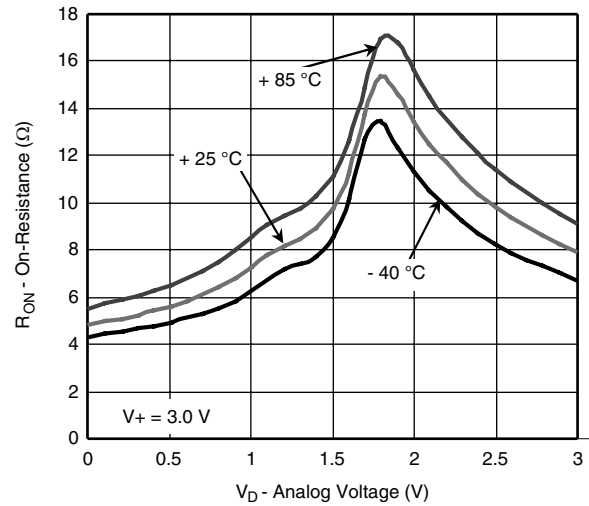

**RON vs. VD and Temperature**

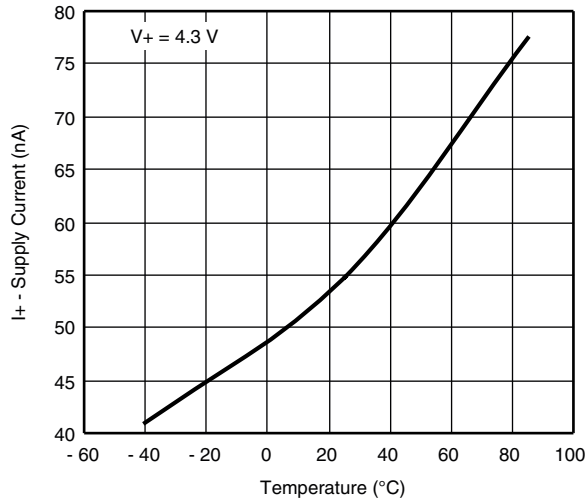

**Supply Current vs. Temperature**

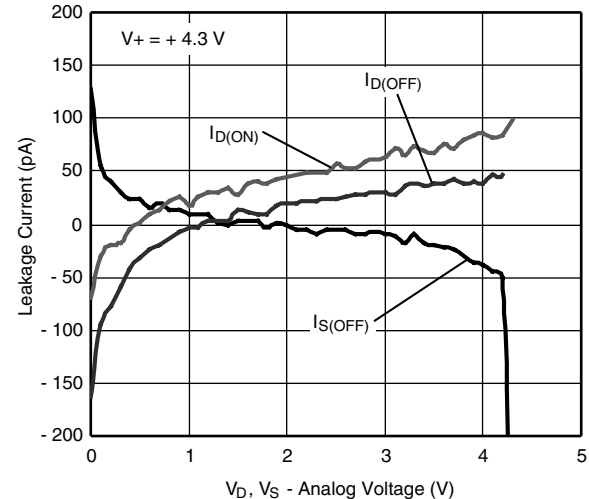

**Leakage vs. Analog Voltage**

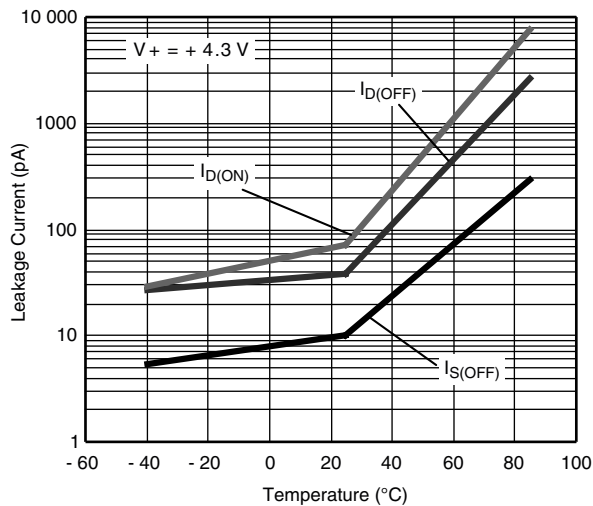

**Leakage Current vs. Temperature**

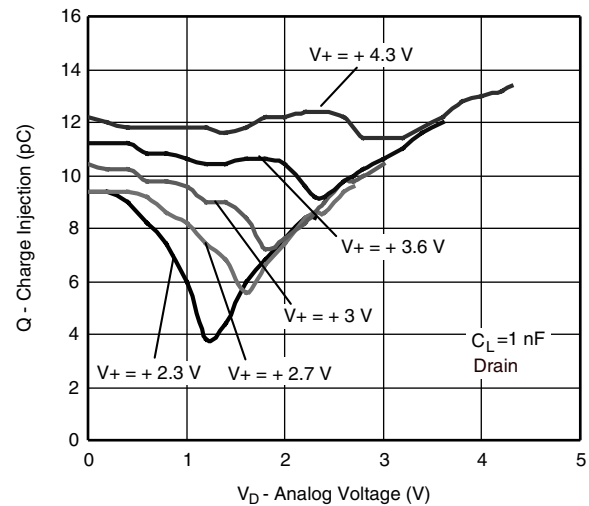

**Charge Injection vs. Analog Voltage**

**TYPICAL CHARACTERISTICS** 25 °C, unless otherwise noted

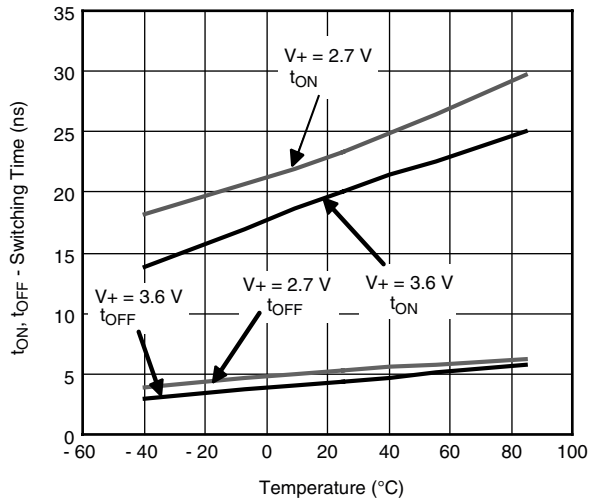

Switching Time vs. Temperature

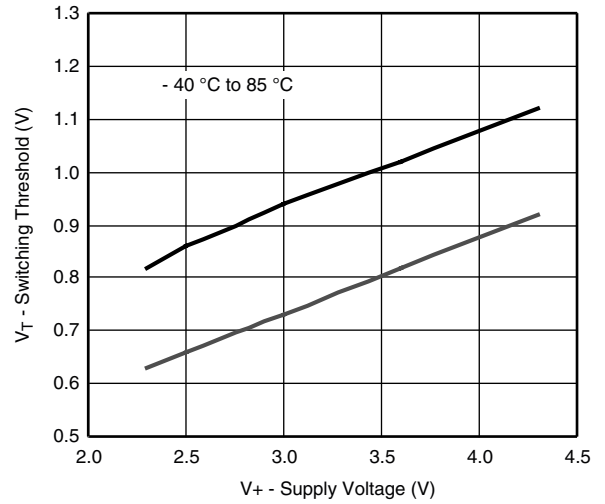

Switching Threshold vs. Supply Voltage

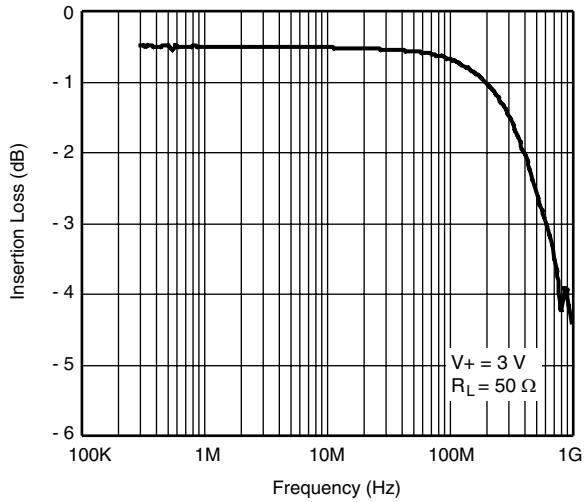

Insertion Loss vs. Frequency

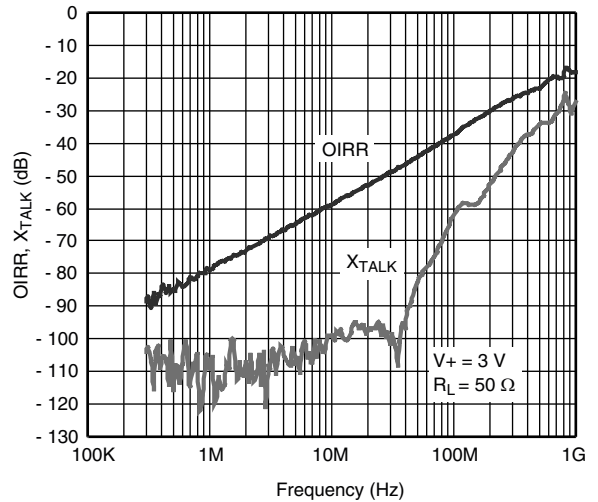

Off-Isolation, Crosstalk vs. Frequency

**TEST CIRCUITS**

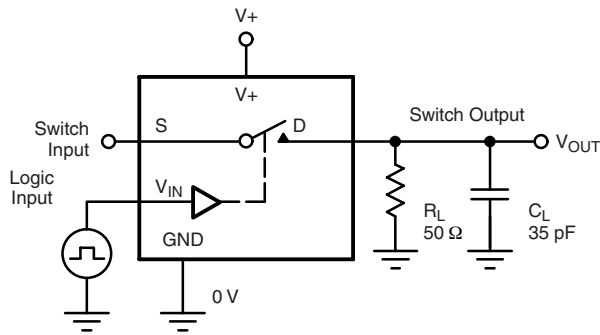

$C_L$  (includes fixture and stray capacitance)

$$V_{OUT} = V_D \left( \frac{R_L}{R_L + R_{ON}} \right)$$

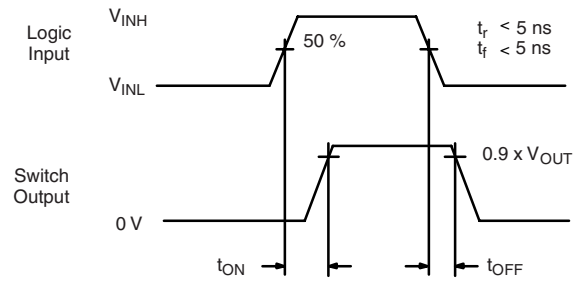

Logic "1" = Switch On  
Logic input waveforms inverted for switches that have the opposite logic sense.

**Figure 1. Switching Time**

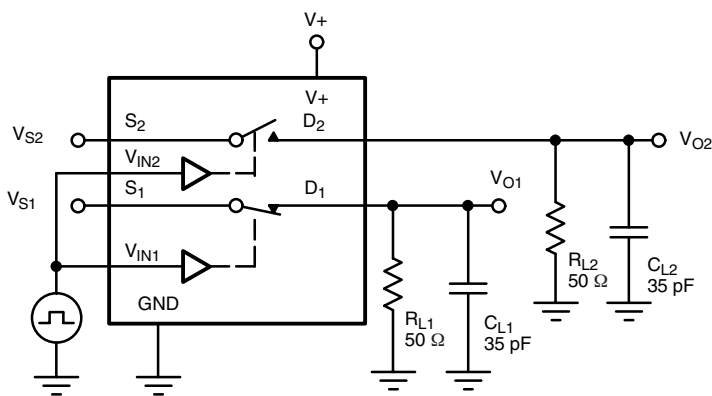

$C_L$  (includes fixture and stray capacitance)

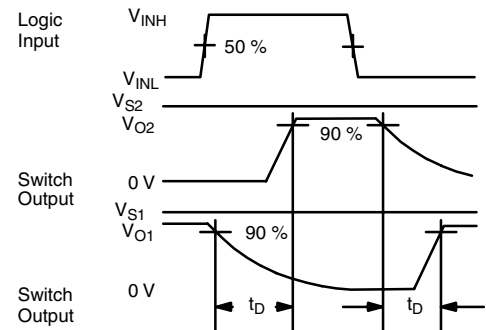

**Figure 2. Break-Before-Make (DG2739)**

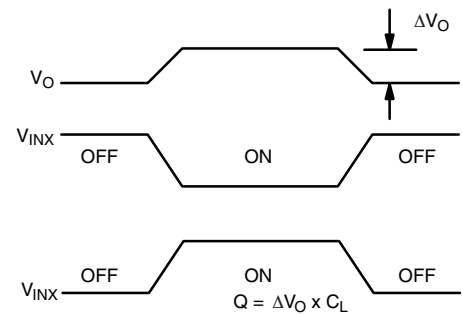
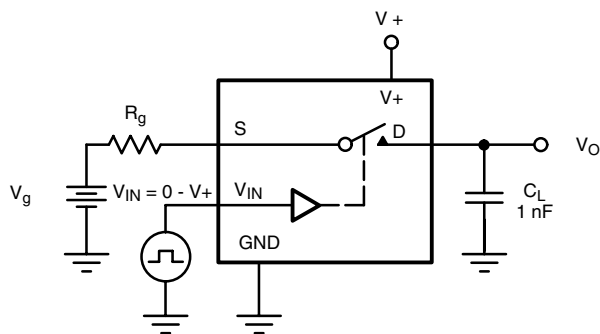

**Figure 3. Charge Injection**

TEST CIRCUITS

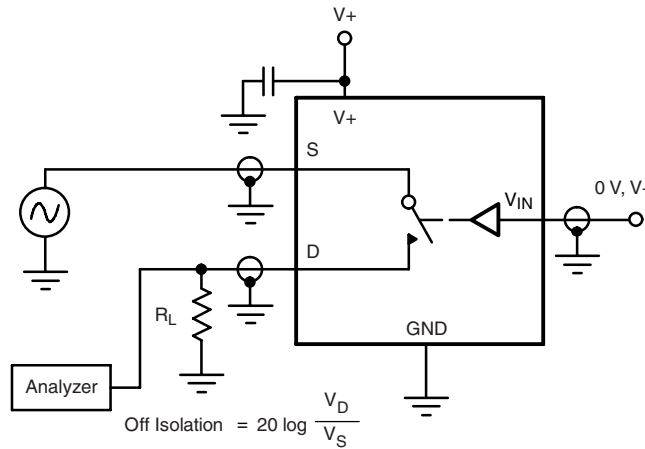

Figure 4. Off-Isolation

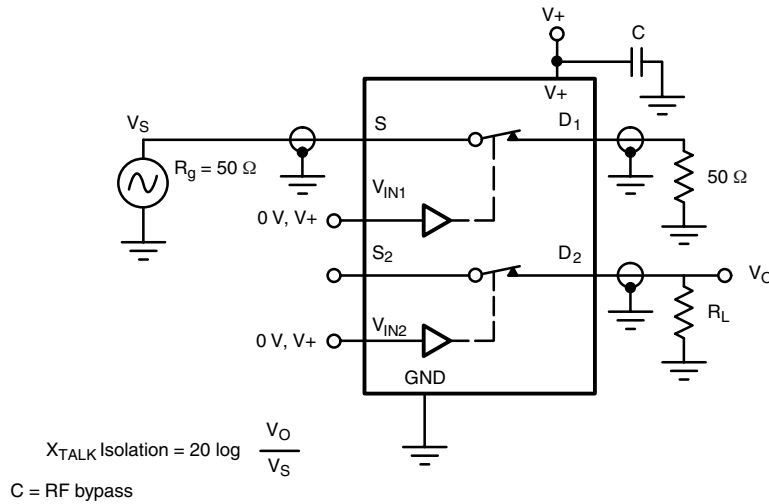

Figure 5. Crosstalk

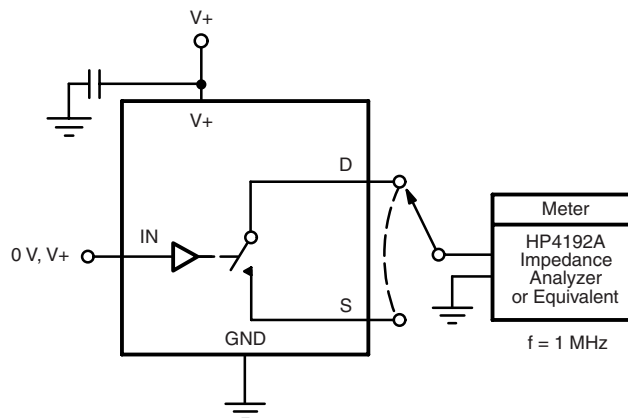
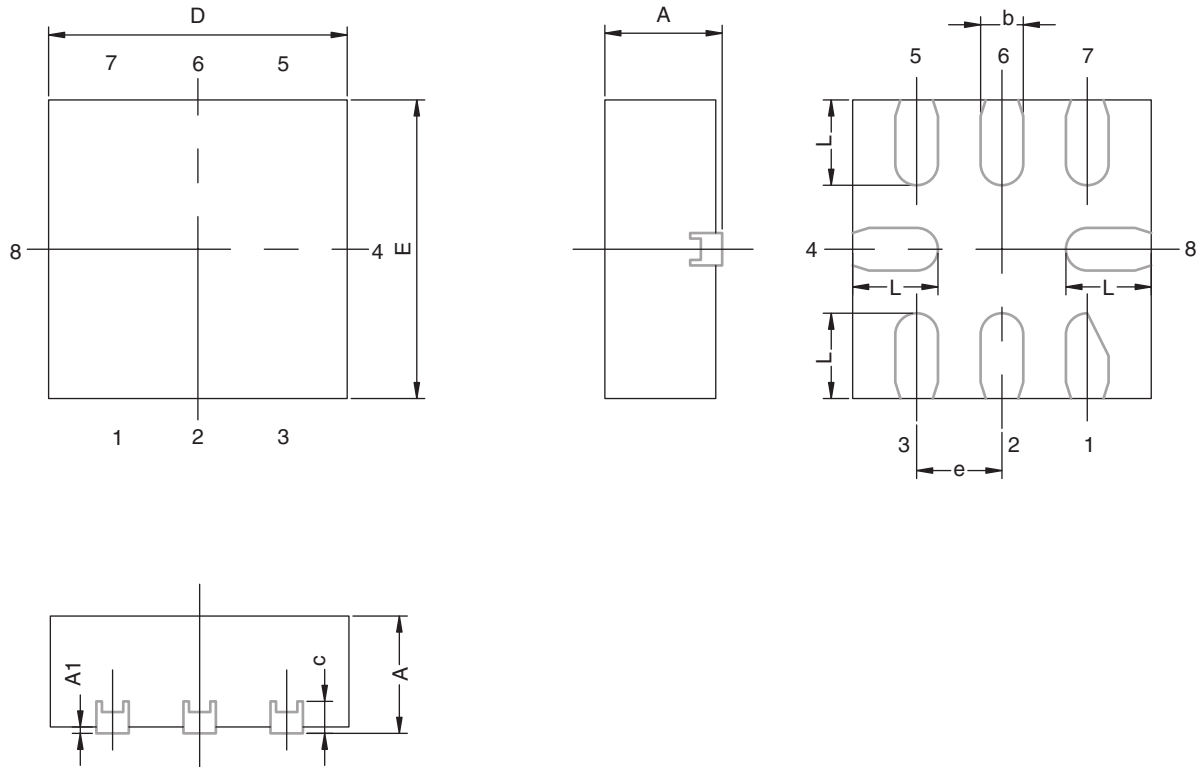

Figure 6. Channel Off/On Capacitance

Vishay Siliconix maintains worldwide manufacturing capability. Products may be manufactured at one of several qualified locations. Reliability data for Silicon Technology and Package Reliability represent a composite of all qualified locations. For related documents such as package/tape drawings, part marking, and reliability data, see <http://www.vishay.com/ppg?68801>.

## MINIQFN-8L CASE OUTLINE



DIM	MILLIMETERS			INCHES		
	MIN.	NOM.	MAX.	MIN.	NOM.	MAX.
A	0.50	0.55	0.60	0.0197	0.0217	0.0236
A1	0.00	-	0.05	0.000	-	0.002
b	0.15	0.20	0.25	0.006	0.008	0.010
c	0.15 REF			0.006 REF		
D	1.35	1.40	1.45	0.053	0.055	0.057
E	1.35	1.40	1.45	0.053	0.055	0.057
e	0.40 BSC			0.016 BSC		
L	0.35	0.40	0.45	0.014	0.016	0.018
ECN: C-08336-Rev. A, 05-May-08						
DWG: 5964						



**RECOMMENDED MINIMUM PADS FOR MINI QFN 8L**

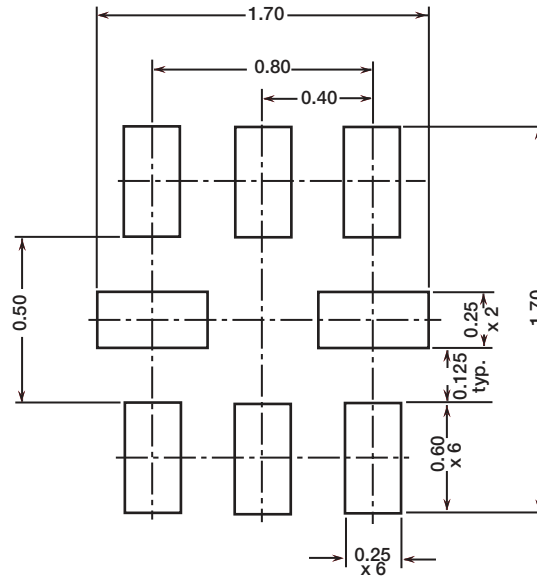

Suggested Minimum Pad  
Dimensions in mm



## Disclaimer

ALL PRODUCT, PRODUCT SPECIFICATIONS AND DATA ARE SUBJECT TO CHANGE WITHOUT NOTICE TO IMPROVE RELIABILITY, FUNCTION OR DESIGN OR OTHERWISE.

Vishay Intertechnology, Inc., its affiliates, agents, and employees, and all persons acting on its or their behalf (collectively, "Vishay"), disclaim any and all liability for any errors, inaccuracies or incompleteness contained in any datasheet or in any other disclosure relating to any product.

Vishay makes no warranty, representation or guarantee regarding the suitability of the products for any particular purpose or the continuing production of any product. To the maximum extent permitted by applicable law, Vishay disclaims (i) any and all liability arising out of the application or use of any product, (ii) any and all liability, including without limitation special, consequential or incidental damages, and (iii) any and all implied warranties, including warranties of fitness for particular purpose, non-infringement and merchantability.

Statements regarding the suitability of products for certain types of applications are based on Vishay's knowledge of typical requirements that are often placed on Vishay products in generic applications. Such statements are not binding statements about the suitability of products for a particular application. It is the customer's responsibility to validate that a particular product with the properties described in the product specification is suitable for use in a particular application. Parameters provided in datasheets and/or specifications may vary in different applications and performance may vary over time. All operating parameters, including typical parameters, must be validated for each customer application by the customer's technical experts. Product specifications do not expand or otherwise modify Vishay's terms and conditions of purchase, including but not limited to the warranty expressed therein.

Except as expressly indicated in writing, Vishay products are not designed for use in medical, life-saving, or life-sustaining applications or for any other application in which the failure of the Vishay product could result in personal injury or death. Customers using or selling Vishay products not expressly indicated for use in such applications do so at their own risk. Please contact authorized Vishay personnel to obtain written terms and conditions regarding products designed for such applications.

No license, express or implied, by estoppel or otherwise, to any intellectual property rights is granted by this document or by any conduct of Vishay. Product names and markings noted herein may be trademarks of their respective owners.

## Material Category Policy

**Vishay Intertechnology, Inc. hereby certifies that all its products that are identified as RoHS-Compliant fulfill the definitions and restrictions defined under Directive 2011/65/EU of The European Parliament and of the Council of June 8, 2011 on the restriction of the use of certain hazardous substances in electrical and electronic equipment (EEE) - recast, unless otherwise specified as non-compliant.**

**Please note that some Vishay documentation may still make reference to RoHS Directive 2002/95/EC. We confirm that all the products identified as being compliant to Directive 2002/95/EC conform to Directive 2011/65/EU.**

**Vishay Intertechnology, Inc. hereby certifies that all its products that are identified as Halogen-Free follow Halogen-Free requirements as per JEDEC JS709A standards. Please note that some Vishay documentation may still make reference to the IEC 61249-2-21 definition. We confirm that all the products identified as being compliant to IEC 61249-2-21 conform to JEDEC JS709A standards.**