

NPN HIGH POWER SILICON TRANSISTOR
Qualified per MIL-PRF-19500/ 371
Devices
2N3902
2N5157
Qualified Level
**JAN
JANTX**
MAXIMUM RATINGS

Ratings	Symbol	2N3902	2N5157	Unit
Collector-Emitter Voltage	V_{CEO}	400	500	Vdc
Emitter-Base Voltage	V_{EBO}	5.0	6.0	Vdc
Collector-Base Voltage	V_{CBO}	700		Vdc
Base Current	I_B	2.0		Adc
Collector Current	I_C	3.5		Adc
Total Power Dissipation	P_T	@ $T_A = +25^{\circ}C$ ⁽¹⁾	5.0	W
		@ $T_C = +75^{\circ}C$ ⁽²⁾	100	W
Operating & Storage Temperature Range	T_j, T_{stg}	-65 to +200		$^{\circ}C$

THERMAL CHARACTERISTICS

Characteristics	Symbol	Max.	Unit
Thermal Resistance, Junction-to-Case	$R_{\theta JC}$	1.25	$^{\circ}C/W$

 1) Derate linearly 29 mW/ $^{\circ}C$ for $T_A > +25^{\circ}C$

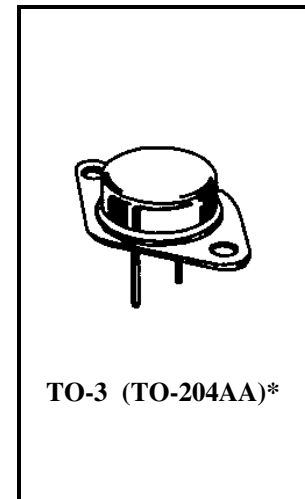
 2) Derate linearly 0.8 W/ $^{\circ}C$ for $T_C > +75^{\circ}C$

*See Appendix A for Package Outline

ELECTRICAL CHARACTERISTICS

Characteristics	Symbol	Min.	Max.	Unit
-----------------	--------	------	------	------

OFF CHARACTERISTICS

Collector-Emitter Cutoff Current $V_{CE} = 325$ Vdc $V_{CE} = 400$ Vdc	2N3902 2N5157	I_{CEO}	250 250	μ Adc
Collector-Emitter Cutoff Current $V_{BE} = 1.5$ Vdc; $V_{CE} = 700$ Vdc		I_{CEX}	500	μ Adc
Emitter-Base Cutoff Current $V_{EB} = 5.0$ Vdc $V_{EB} = 6.0$ Vdc	2N3902 2N5157	I_{EBO}	200 200	μ Adc

ON CHARACTERISTICS⁽³⁾

Base-Emitter Saturation Voltage $I_C = 1.0$ Adc; $I_B = 0.1$ Adc $I_C = 3.5$ Adc; $I_B = 0.7$ Adc		$V_{BE(sat)}$	1.5 2.0	Vdc
Collector-Emitter Saturation Voltage $I_C = 1.0$ Adc; $I_B = 0.1$ Adc $I_C = 3.5$ Adc; $I_B = 0.7$ Adc		$V_{CE(sat)}$	0.8 2.5	Vdc

2N3902, 2N5157 JAN SERIES

ELECTRICAL CHARACTERISTICS (con't)

Characteristics	Symbol	Min.	Max.	Unit
ON CHARACTERISTICS⁽³⁾ (con't)				
Forward-Current Transfer Ratio I _C = 0.5 Adc; V _{CE} = 5.0 Vdc I _C = 1.0 Adc; V _{CE} = 5.0 Vdc I _C = 2.5 Adc; V _{CE} = 5.0 Vdc I _C = 3.5 Adc; V _{CE} = 5.0 Vdc	h _{FE}	25 30 10 5	90	
Collector-Emitter Sustaining Voltage I _C = 100 mAdc	V _{CEO(sus)}	325 400		Vdc

DYNAMIC CHARACTERISTICS

Small-Signal Short-Circuit Forward Current Transfer Ratio I _C = 0.2 Adc; V _{CE} = 10 Vdc, f = 1 MHz	h _{fc}	2.5	25	
Output Capacitance V _{CB} = 10 Vdc; I _E = 0, 100 kHz ≤ f ≤ 1.0 MHz	C _{obo}		250	pF

SWITCHING CHARACTERISTICS

Turn-On Time V _{CC} = 125 Vdc; I _C = 1.0 Adc; I _{B1} = 0.1 Adc	t _{on}		0.8	μs
Turn-Off Time V _{CC} = 125 Vdc; I _C = 1.0 Adc; I _{B1} = 0.1 Adc; -I _{B2} = 0.50 Adc	t _{off}		1.7	μs

SAFE OPERATING AREA

DC Tests (continuous)				
T _C = +25°C; t ≥ 1.0 s (See Figure 3 of MIL-PRF-19500/371)				
Test 1				
V _{CE} = 28.6 Vdc, I _C = 3.5 Adc				
Test 2				
V _{CE} = 70 Vdc, I _C = 1.43 Adc				
Test 3				
V _{CE} = 325 Vdc, I _C = 55 mAdc	2N3902			
V _{CE} = 400 Vdc, I _C = 35 mAdc	2N5157			
Switching Tests				
Load condition C (unclamped inductive load)				
T _C = 25°C; duty cycle ≤ 10%; R _S = 0.1 Ω (See Figure 4 of MIL-PRF-19500/371)				
Test 1				
t _p = approximately 3 ms (vary to obtain I _C); R _{BB1} = 20 Ω; V _{BB1} = 10 Vdc; R _{BB2} = 3 kΩ; V _{BB2} = 1.5 Vdc; V _{CC} = 50 Vdc; I _C = 3.5 Adc; L = 60 mH; R = 3 Ω; R _L ≤ 14Ω.				
Test 2				
t _p = approximately 3 ms (vary to obtain I _C); R _{BB1} = 100 Ω; V _{BB1} = 10 Vdc; R _{BB2} = 3 kΩ; V _{BB2} = 1.5 Vdc; I _C = 0.6 Adc V _{CC} = 50 Vdc; L = 200 mH; R = 8 Ω; R _L ≤ 83Ω.				
Switching Tests				
Load condition (clamped inductive load)				
T _C = +25°C; duty cycle ≤ 10%. (See Figure 5 of MIL-PRF-19500/371)				
Test 1				
t _p = approximately 30 ms (vary to obtain I _C); R _S = 0.1 Ω; R _{BB1} = 20 Ω; V _{BB1} = 10 Vdc; R _{BB2} = 100 Ω; V _{BB2} = 1.5 Vdc; V _{CC} = 50 Vdc; I _C = 3.5 Adc; L = 60 mH; R = 3 Ω; R _L ≥ 0Ω. (A suitable clamping circuit or diode can be used.)				
Clamp Voltage = 400 +0, -5 Vdc	2N3902			
Clamp Voltage = 500 +0, -5 Vdc	2N5157			
(Clamped voltage must be reached)				

3.) Pulse Test: Pulse Width = 300μs, Duty Cycle ≤ 2.0%.