



austriamicrosystems AG

is now

ams AG

The technical content of this austriamicrosystems datasheet is still valid.

Contact information:

Headquarters:

ams AG

Tobelbaderstrasse 30

8141 Unterpremstaetten, Austria

Tel: +43 (0) 3136 500 0

e-Mail: ams_sales@ams.com

Please visit our website at www.ams.com

AS1390A, AS1390B

High Power Boost Controller and Buck Converter for LED Backlight

1 General Description

The AS1390A, AS1390B is a high-power, constant-frequency boost controller with an integrated buck converter. The AS1390A can be used for the boost converter in TV sets which are optimized for 2D and 3D mode. AS1390B is designed for single mode operation.

The continuous conduction mode of the AS1390 provides superior bandwidth and transient response. The two output voltages for the boost controller (2D and 3D mode) can be programmed with an external resistor divider.

The buck converter is optimized for supplying a μ P with 5V.

The AS1390A is available in a 20-Pin QFN (4x4mm) package, the AS1390B comes in a 16-pin SOIC package.

2 Key Features

- High Efficiency: Up to 95%
- Supply Voltage Range: 10V to 30V
- Boost Output Current: up to 3A
- Continuous Conduction Mode
- Undervoltage Lockout with hysteresis
- Overvoltage, Overcurrent and Overtemperature Protection
- Low Dropout Operation: 90% Duty Cycle
- Buck always ON, Boost with enable PIN
- Packages:
 - 20-Pin QFN (4x4mm)
 - 16-pin SOIC

3 Applications

The device is ideal for LED backlighting for LCD - TV sets and monitors.

Figure 1. AS1390A - Typical Application

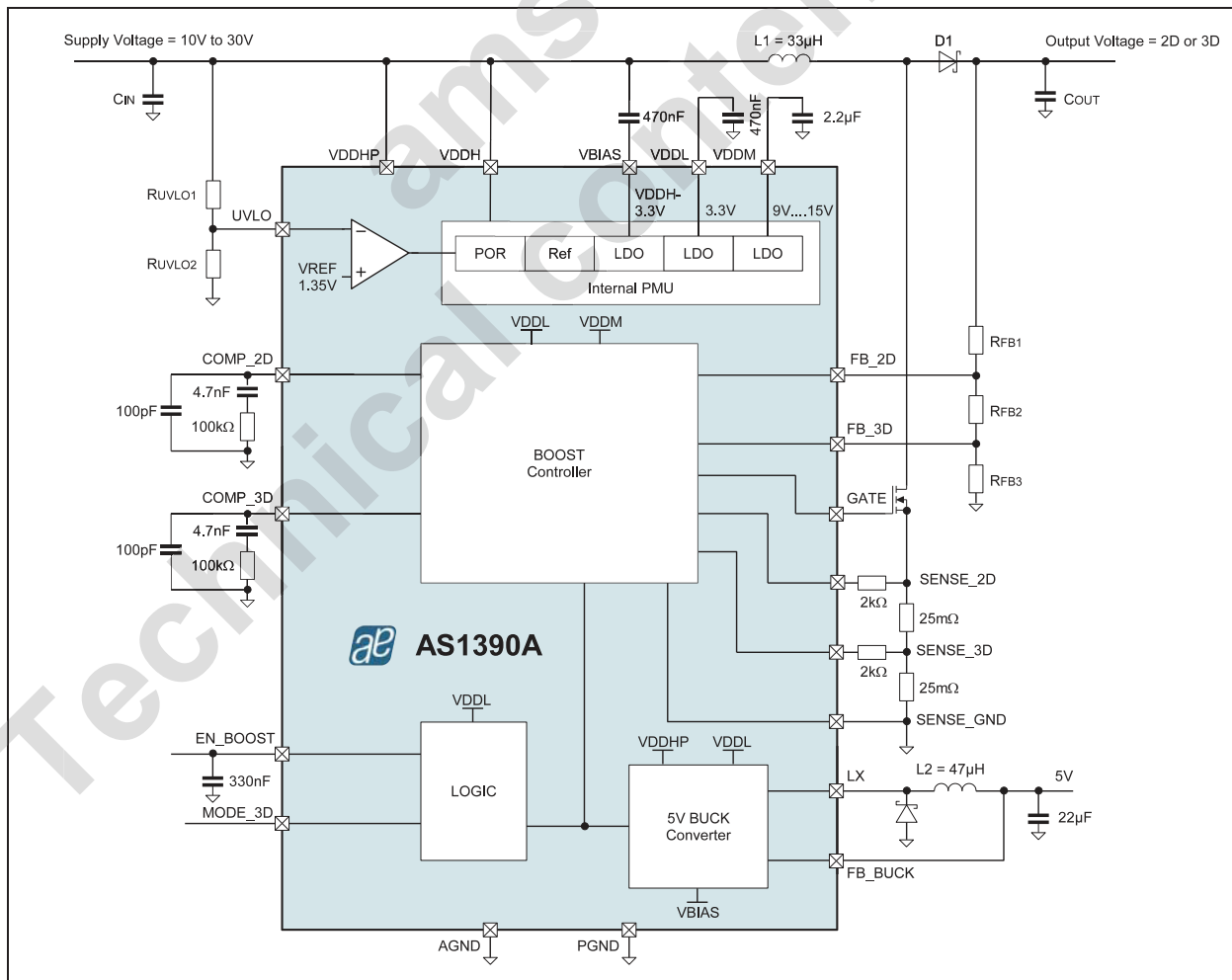
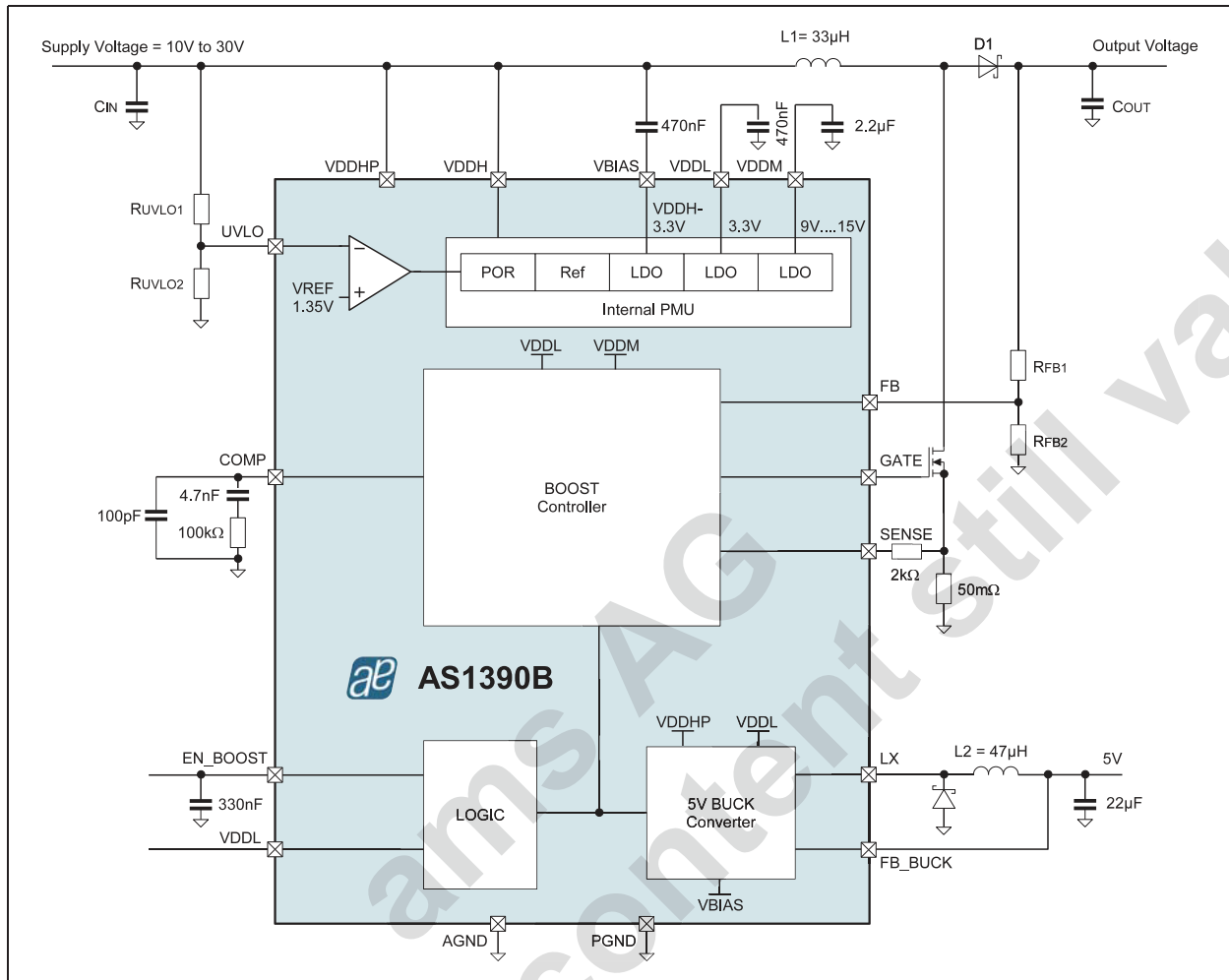
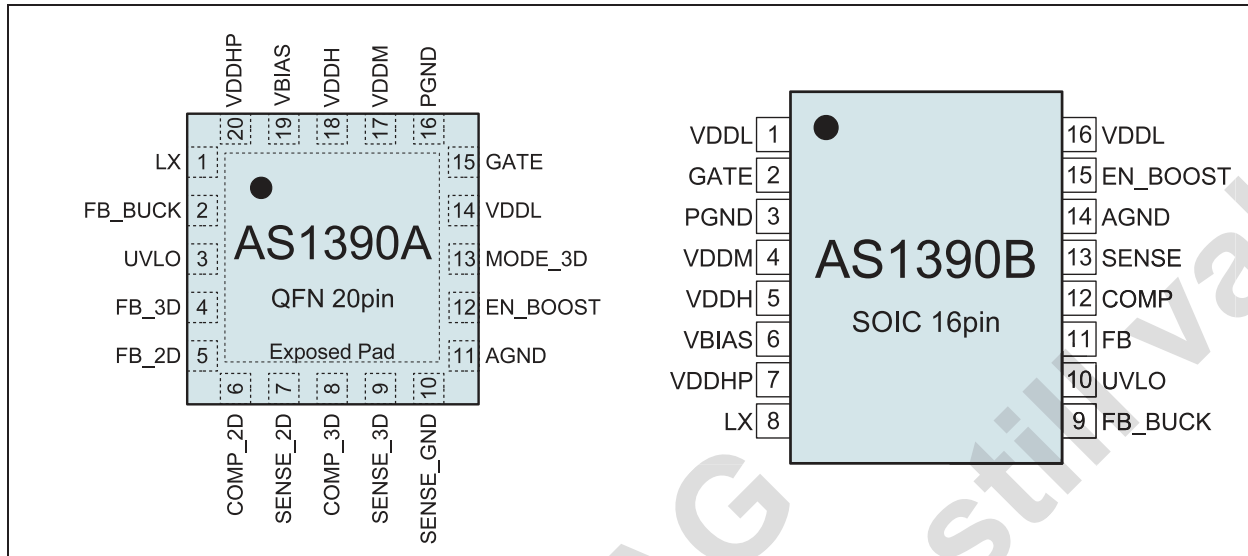

Figure 2. AS1390B - Typical Application



4 Pin Assignments

Figure 3. Pin Assignments (Top View)



4.1 Pin Descriptions

Table 1. Pin Descriptions

Pin Number		Pin Name	Pin Typ	Description
AS1390A	AS1390B			
13	5	VDDH	P	Supply Voltage
3	10	UVLO	A I/O	Undervoltage Lockout
6	12	COMP_2D	A I/O	Compensation Network 2D. default
8		COMP_3D	A I/O	Compensation Network 3D
19	6	VBIAS	A I/O	High Side Regulator Output. Connect this pin to the Supply rail via a capacitor.
14	1, 16	VDDL	A I/O	Internal Regulator Output
17	4	VDDM	A I/O	Drive Voltage Regulator Output
5	11	FB_2D	A I/O	FB Input 2D. default
4		FB_3D	A I/O	FB Input 3D
15	2	GATE	A I/O	Gate Driver Output
7	13	SENSE_2D	A I/O	Current Sense Input 2D. default
9		SENSE_3D	A I/O	Current Sense Input 3D
10	-	SENSE_GND	A I/O	Current Sense Input GND. (only for AS1390A)
1	8	LX	A I/O	Inductor Connector. Connect an inductor from LX to the output of the buck converter
2	9	FB_BUCK	A I/O	Feedback Buck Pin. Connect this pin to the output of the buck converter
20	7	VDDHP	P	Supply for DCDC Buck-Converter
16	3	PGND	P	Power Ground
11	14	AGND	P	Analog Ground
12	15	EN_BOOST	D IN	Enable. Enables the Boost-Controller. 1 = Normal operation; 0 = Shutdown;
13	-	MODE_3D	D IN	Selection for 3D Mode. (only for AS1390A) 1 = 3D; 0 = 2D;
	-	Exposed Pad	n.c.	Exposed Pad. This pad is not connected internally. Can be left floating or connect to GND to achieve an optimal thermal performance.

5 Absolute Maximum Ratings

Stresses beyond those listed in Table 2 may cause permanent damage to the device. These are stress ratings only, and functional operation of the device at these or any other conditions beyond those indicated in Electrical Characteristics on page 5 is not implied. Exposure to absolute maximum rating conditions for extended periods may affect device reliability.

Table 2. Absolute Maximum Ratings

Parameter	Min	Max	Units	Notes
Electrical Parameters				
VDDH to AGND		40	V	
VDDL to AGND		5.0	V	
VDDM to AGND		20	V	
VBIAS to AGND	VDDH - 5.0	VDDH + 0.3	V	
PGND to AGND	-0.3	+0.3	V	
EN_BOOST, FB_2D, FB_3D, FB_BUCK	AGND - 0.3	VDD + 0.3	V	
Input Current (latch-up immunity)	-100	100	mA	Norm: JEDEC 78
Electrostatic Discharge				
Human Body Model @ VDDH, VDDM, LX, VBIAS, GATE, VDDHP		4	kV	Norm: MIL 883 E method 3015
Human Body Model all other pins		2	kV	
Temperature Ranges and Storage Conditions				
Junction Temperature (T _{J-MAX})		+150	°C	
Storage Temperature Range	-65	+150	°C	
Package Body Temperature		+260	°C	The reflow peak soldering temperature (body temperature) specified is in accordance with IPC/JEDEC J-STD-020 "Moisture/Reflow Sensitivity Classification for Non-Hermetic Solid State Surface Mount Devices". The lead finish for Pb-free leaded packages is matte tin (100% Sn).
Humidity non-condensing	5	85	%	
Moisture Sensitive Level	1			Represents a max. floor life time of unlimited for 20-Pin QFN (4x4mm)
	3			Represents a max. floor life time of 168h for 16-pin SOIC

6 Electrical Characteristics

VDDH = 24V, EN_BOOST = 5V, unless otherwise noted. Typical values are at TA=25°C. All limits are guaranteed. The parameters with min and max values are guaranteed with production tests or SQC (Statistical Quality Control) methods.

Table 3. Electrical Characteristics

Symbol	Parameter	Conditions	Min	Typ	Max	Units
TA	Operating Temperature Range		-40		+85	°C
TJ	Operating Junction Temperature Range		-40		+125	°C
VDDH	Supply Voltage Range ¹		10		30	V
VFB	Feedback Voltage			1.25		V
IQ	Quiescent Supply Current			1		mA
Boost Converter						
VOUT Boost ²	Output Voltage Range		30		90	V
	Accuracy		-2		+2	%
IOUT Boost	Output current Boost Converter ³			1000	3000	mA
fsw	Boost Switching Frequency			275		kHz
Buck Converter						
VOUT Buck	Output Voltage Range			5		V
	Accuracy	IOUT Buck = 50mA	-5.0		+5.0	%
IOUT Buck	Output current Buck Converter			100		mA
fsw	Buck Switching Frequency			1000		kHz
RON_Buck	Driver ON Resistance Buck			3		Ω
Driver Stage						
RSWON1	Driver ON Resistance Top			8		Ω
RSWON2	Driver ON Resistance Bottom			8		Ω
VDRV,peak	Driver Peak Voltage (voltage @ VDDM)			9		V
tRISE	Driver Pin Rise Time	CGS = 3nF, VDDM = 9V, VDRV = 0 to 3V		25		ns
tFALL	Driver Pin Fall Time			25		ns
Undervoltage Lockout						
VREF	UVLO Reference Voltage			1.35		V
IHYST	Hysteresis Current			20		μA
Enable						
VIH,EN VIH,MODE	Logic high input threshold		1.8			V
VIL,EN VIL,MODE	Logic low input threshold				0.8V	V

Table 3. Electrical Characteristics

Symbol	Parameter	Conditions	Min	Typ	Max	Units
Thermal Protection						
	Thermal Shutdown Threshold			140		°C
	Thermal Shutdown Hysteresis			30		°C

1. Depending on external components an extended Supply Voltage Range up to 40V is possible.
2. Guaranteed by design and characterisation. Depending on external components an extended Output Voltage Range up to 200V is possible.
3. Depending on parameters of external transistor and max. allowed heat dissipation of the external transistor.

7 Operating Characteristics

V_{OUT Boost} = 60V, I_{OUT Boost} = 1A, V_{OUT Buck} = 5V, I_{OUT Buck} = 50mA, T_A = +25°C (unless otherwise specified);

Figure 4. Boost - Efficiency vs. Output Current; V_{IN} = 12V

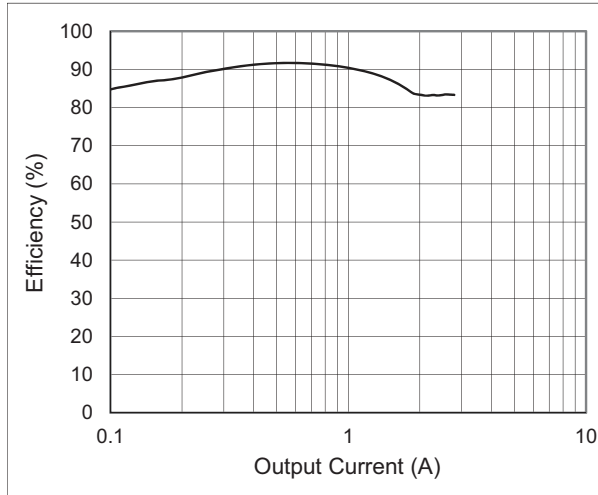

Figure 5. Boost - Output Voltage vs. Output Current; V_{IN} = 12V

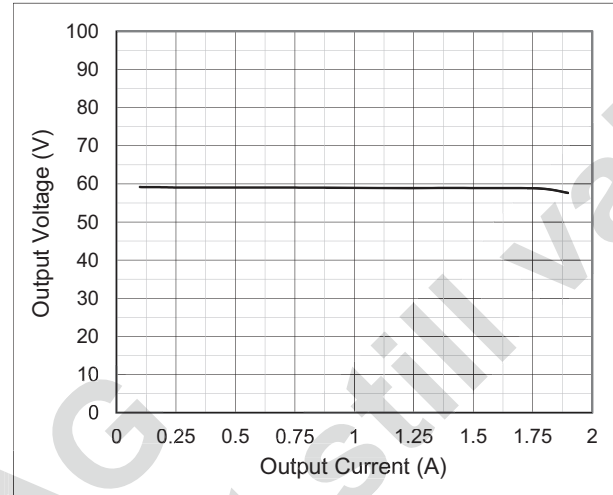

Figure 6. Boost - Efficiency vs. Output Current; V_{IN} = 24V

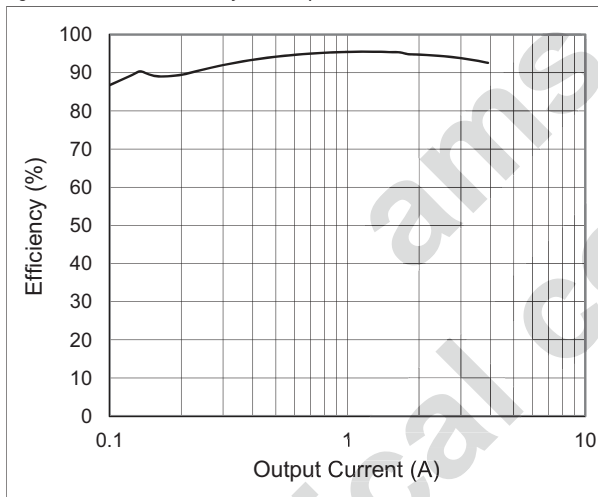

Figure 7. Boost - Efficiency vs. Input Voltage

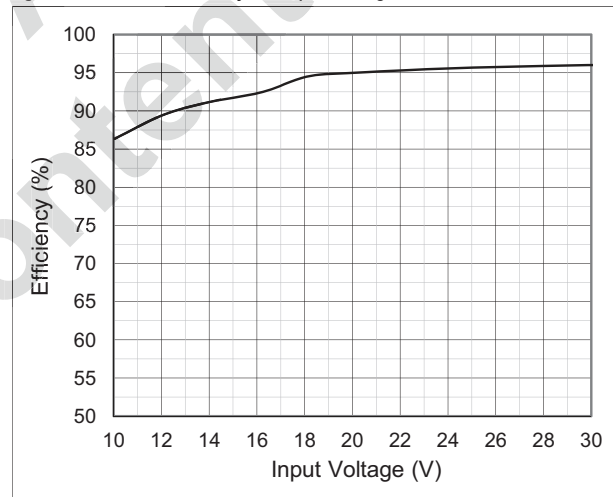

Figure 8. Boost - Output Voltage vs. Output Current; V_{IN} = 24V

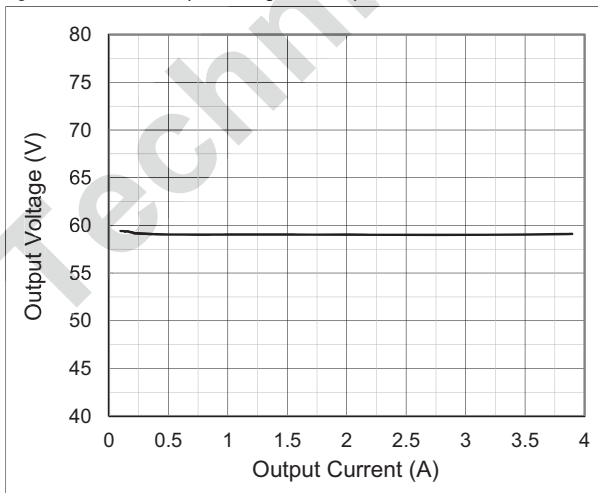

Figure 9. Boost - V_{OUT} vs. Temp.; V_{IN} = 24V, I_{OUT} = 200mA

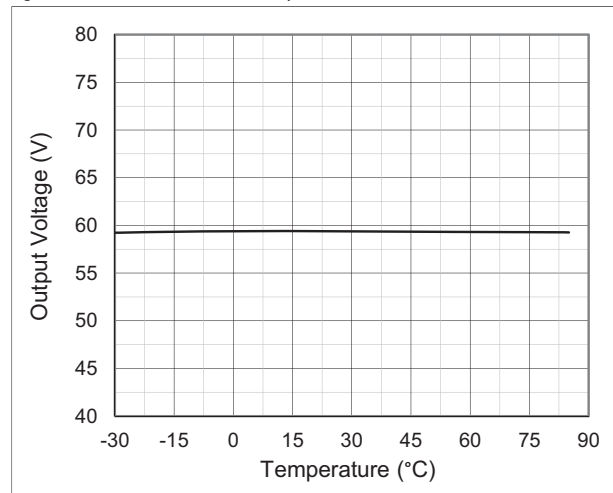

Figure 10. Buck - Efficiency vs. Output Current; $V_{IN} = 12V$

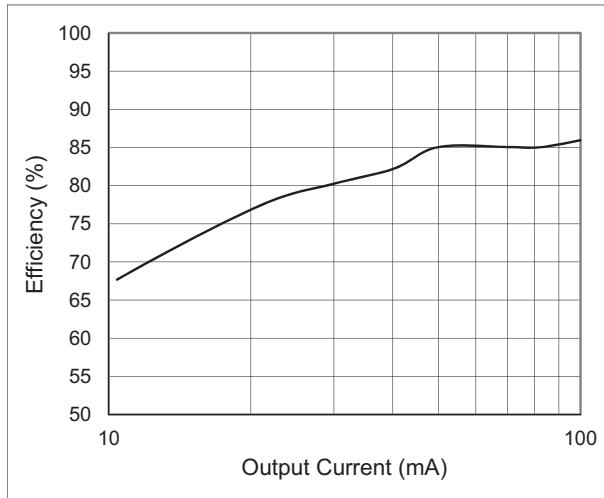

Figure 11. Buck - Output Voltage vs. Output Current; $V_{IN} = 12V$

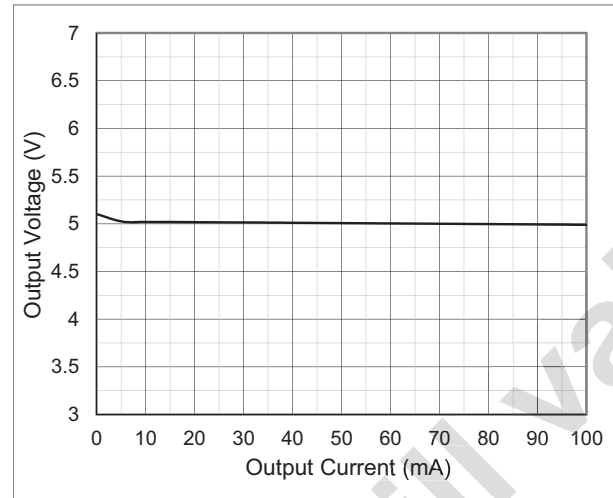

Figure 12. Buck - Efficiency vs. Output Current; $V_{IN} = 24V$

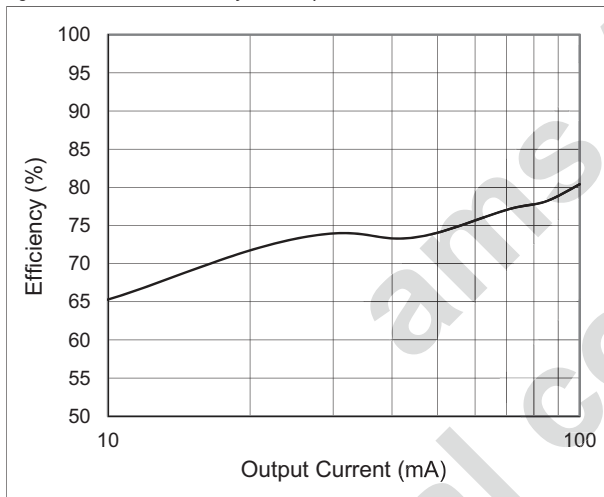

Figure 13. Buck - Output Voltage vs. Output Current; $V_{IN} = 24V$

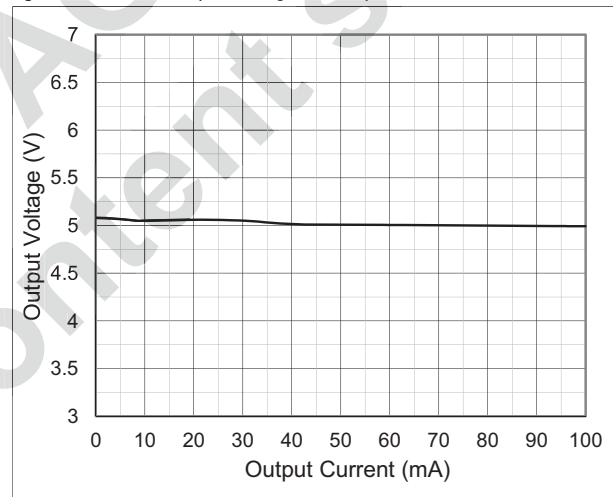

Figure 14. Buck - Efficiency vs. Input Voltage

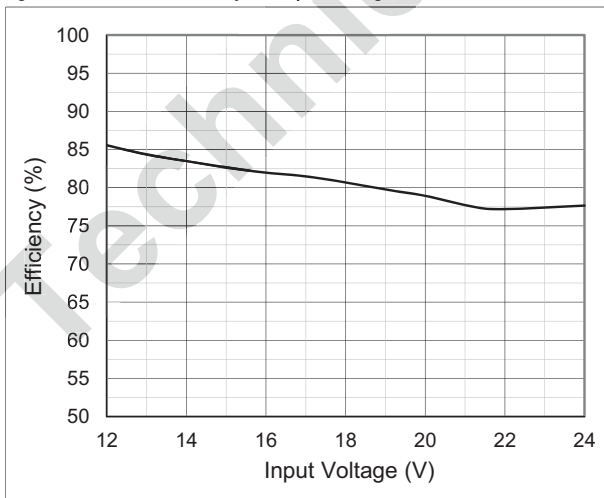

Figure 15. Buck - V_{OUT} vs. Temp.; $V_{IN} = 24V$

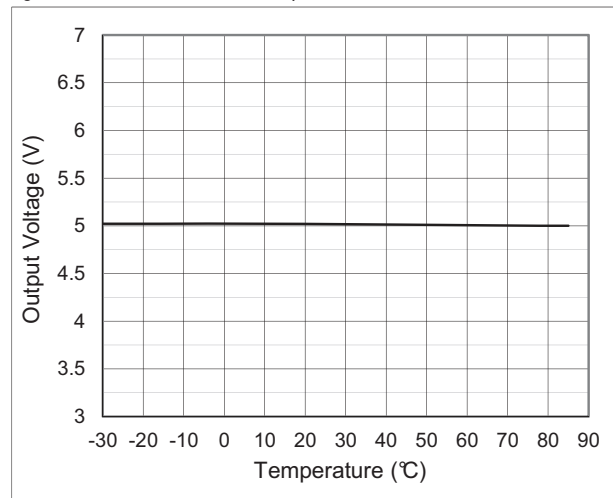

Figure 16. Load Regulation

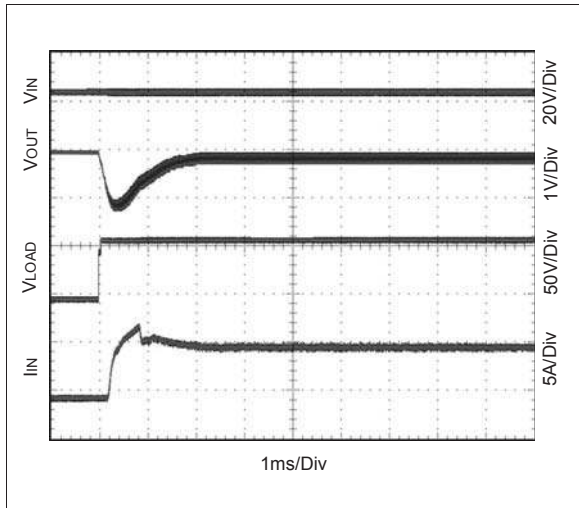
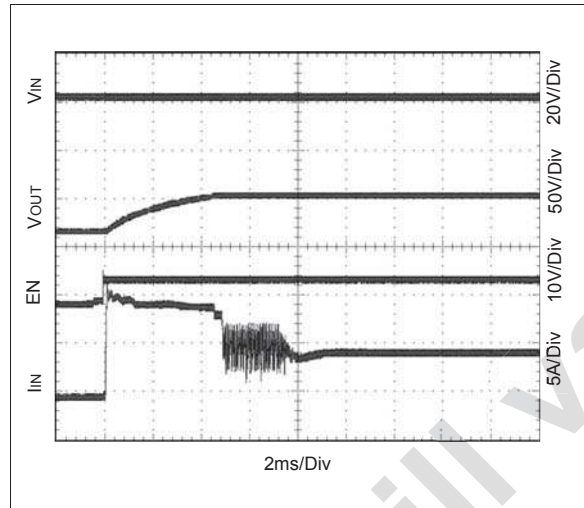

Figure 17. Start with EN_BOOST pin



ams AG
Technical content still valid

8 Detailed Description

The AS1390 is a high efficiency, high voltage and high current DC-DC Step-up controller combined with an Step-down converter. The device is designed for LED backlight in LCD TV-sets. The special feature is the optimized operation point for the 2D and 3D mode. Hence the output voltage of the Step-up Converter can easily be switched via the MODE_3D pin from one voltage to the other.

Figure 18. Detailed Block Diagram Boost Converter

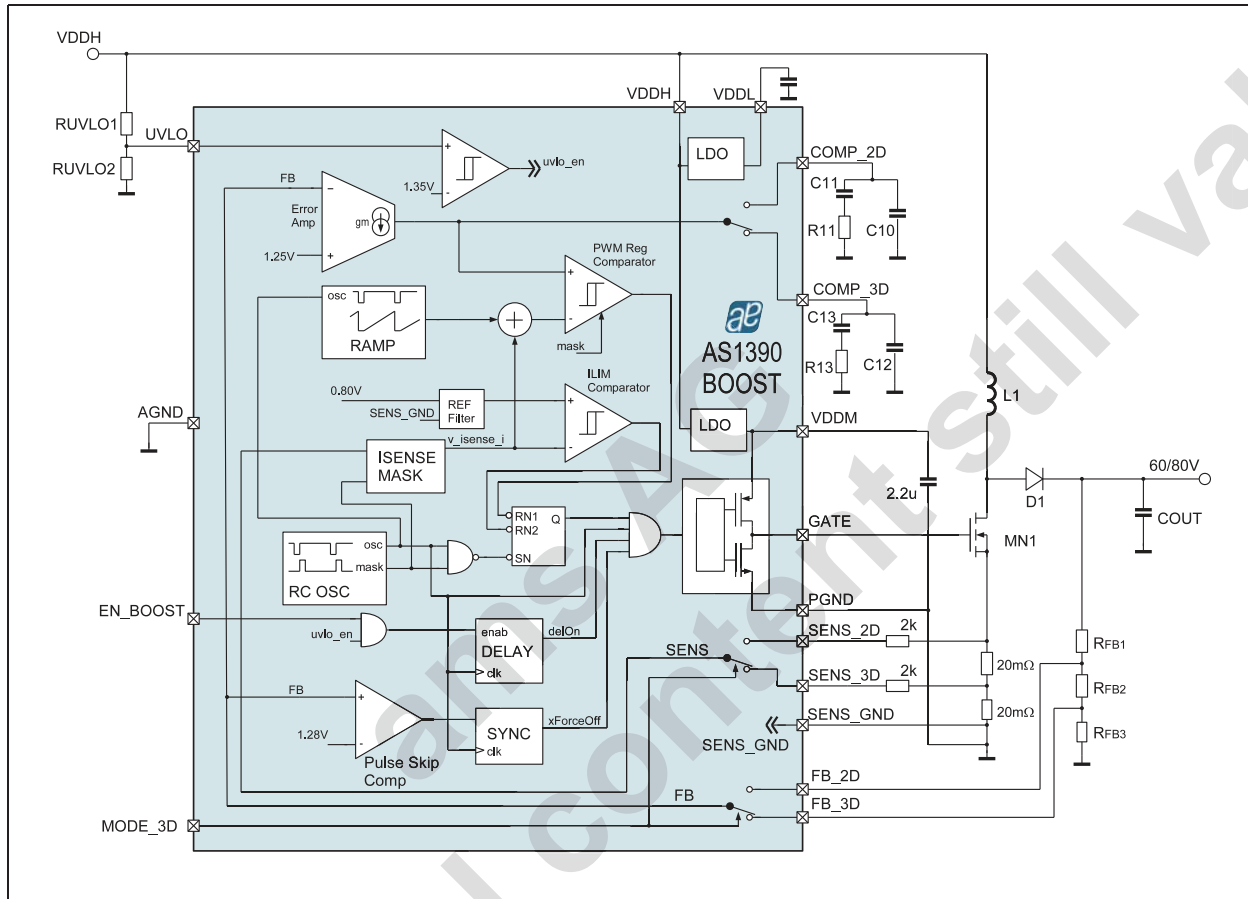

8.1 Boost Controller

8.1.1 Setting output voltages

The Output voltages of the AS1390 are defined by a voltage divider between the FB pin and Vout. Due to the capability of the AS1390 to switch between two output voltages, two dividers are necessary to adjust both output voltages.

Output voltage for 2D-Mode:

$$V_{OUT-2D} = V_{FB} \times \left(1 + \frac{R_{FB1}}{R_{FB2} + R_{FB3}} \right) \quad (EQ 1)$$

Output voltage for 3D-Mode:

$$V_{OUT-3D} = V_{FB} \times \left(1 + \frac{R_{FB1} + R_{FB2}}{R_{FB3}} \right) \quad (EQ 2)$$

Where: $V_{FB} = 1.25V$

Note: The overall resistance should be in the range of 100k to 200kΩ to avoid any noise issues.

8.1.2 Undervoltage-Lockout (UVLO)

To enable the usage of the circuit with a wide input voltage range (typ. 12V and 24V), the threshold for undervoltage detection should be selectable by external components. Therefore a PAD UVLO is implemented, with an external resistor that selects the value of the threshold and implements also a hysteresis. Till UVLOCO gets deactivated, the threshold is higher, after UVLOCO is 0 (no undervoltage condition), the threshold is lowered by a switch-on of a constant current source.

If the undervoltage-lockout is not needed connect the UVLO pin to VDDL.

Figure 19. UVLO - comparator and external resistor divider

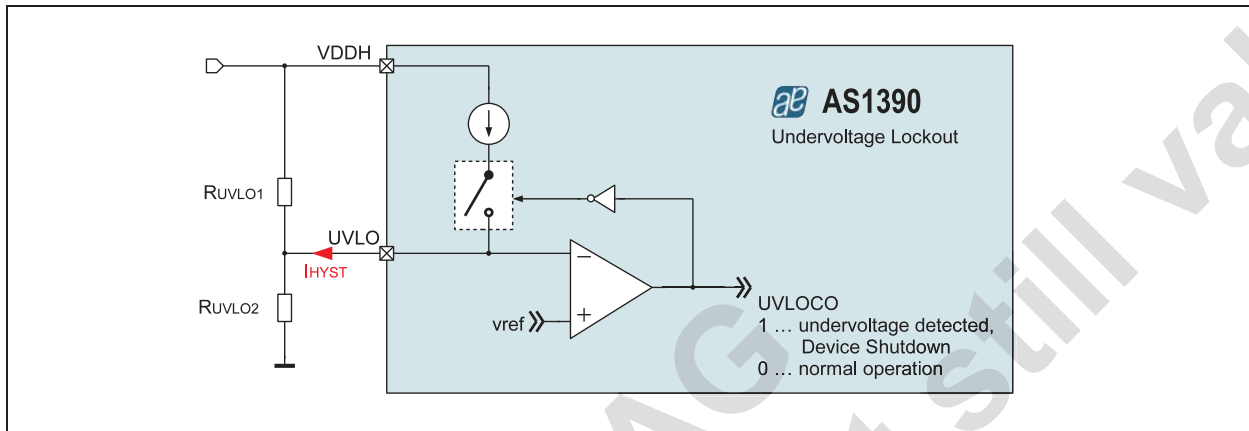
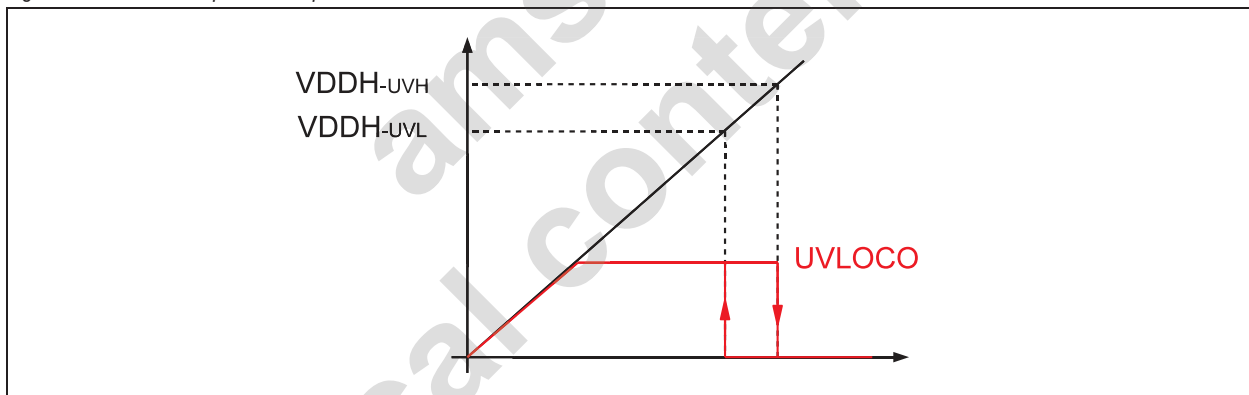

Figure 20. UVLO - comparator Output



Following equations can be derived for adjusting the threshold voltages.

Undervoltage threshold High:

$$V_{DDH-UVH} = V_{REF} \times \left(1 + \frac{R_{UVLO1}}{R_{UVLO2}} \right) \quad (EQ 3)$$

Undervoltage threshold Low:

$$V_{DDH-UVL} = V_{REF} \times \left(1 + \frac{R_{UVLO1}}{R_{UVLO2}} \right) - (I_{HYST} \times R_{UVLO1}) \quad (EQ 4)$$

Where: $I_{HYST} = 20\mu A$

$V_{REF} = 1.35V$

8.1.3 Continuous Conduction Mode (CCM)

For normal operation the converter should stay in continuous conduction mode, to ensure that the inductor value must be bigger than L_{CRIT}.

$$L_{CRIT} = \frac{\left(1 - \frac{V_{IN}}{V_{OUT} + V_D}\right) \times V_{IN}^2 \times R}{2 \times f_{SW} \times (V_{OUT} + V_D)^2} \quad (EQ 5)$$

Where:

V_{IN} ... Input voltage at VDDH

V_{OUT} ... Output voltage

V_D ... Diode forward voltage at D1

f_{sw} ... Switching frequency

R ... Load resistor, should be calculated with minimum current load R = V_{OUT} / I_{OUT_min}

I_{OUT_min} ... Minimum output current (e.g. for LED driver only one LED string is on)

8.1.4 Duty Cycle

Within CCM, the well known relation between input and output voltage is described in the following equation:

$$\frac{V_{OUT} + V_D}{V_{IN}} = \frac{1}{1 - D} \quad (EQ 6)$$

this means for the duty cycle:

$$D = 1 - \frac{V_{IN}}{V_{OUT} + V_D} \quad (EQ 7)$$

8.1.5 Inductor Current

The inductor current varies during a switching cycle. This variation can be expressed by the mean value of the inductor current and the delta rise/fall current within each cycle (see Figure 21).

Figure 21. Inductor Current

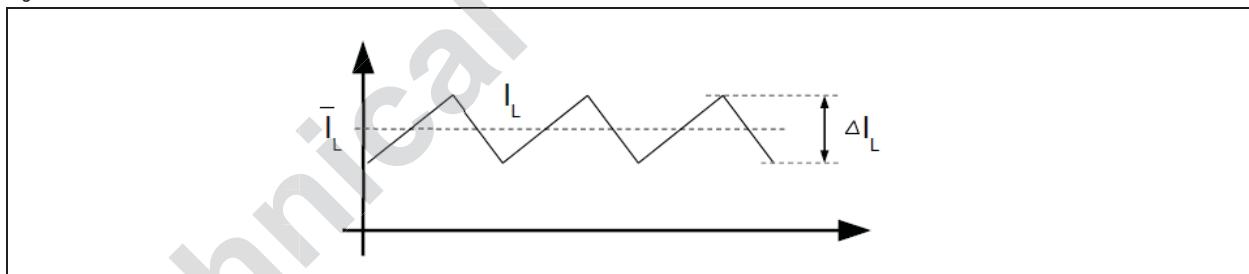

Mean inductor current:

$$\bar{I}_L = \frac{I_{OUT}}{1 - D} \quad (EQ 8)$$

Delta inductor current:

$$\Delta I_L = \frac{D \times V_{IN}}{f_S \times L} \quad (EQ 9)$$

Peak current:

$$I_{pk} = \bar{I}_L + \frac{\Delta I_L}{2} = \frac{I_{OUT}}{1-D} + \frac{D \times V_{IN}}{2 \times f_S \times L} \quad (EQ 10)$$

RMS inductor current:

$$I_{RMS} = \sqrt{\bar{I}_L^2 + (1/12 \times \Delta I_L)^2} \quad (EQ 11)$$

This peak current is flowing through MN1 during phase 1 and through D1 during phase 2 of each cycle. Therefore this peak current is important for a proper diode D1, MOSFET MN1 and inductor L1 selection.

Note: The saturation current of the inductor should be about 20 to 30% larger than the peak current

8.1.6 Input Capacitor

The input capacitor has to supply the delta inductor current and it should be selected according to:

$$C_{IN} > \frac{\Delta I_L}{4 \times \Delta V_{IN} \times f_{SW}} \quad (EQ 12)$$

$$ESR < \frac{\Delta V_{IN}}{2 \times \Delta I_L} \quad (EQ 13)$$

8.1.7 Output Capacitor

The output capacitor must be chosen according to the max allowable output ripple at high load.

$$C_{OUT} > \frac{I_{OUT-max} \times D}{\Delta V_{OUT} \times f_{SW}} \quad (EQ 14)$$

$$ESR < \frac{\Delta V_{OUT}}{\left(\frac{I_{OUT}}{1-D} + \frac{V_{IN} \times D}{2 \times L \times f_{SW}} \right)} \quad (EQ 15)$$

8.1.8 Current Sense Resistor

$$R_{S-max} = \frac{V_{SENSE}}{\bar{I}_L + 0,5 \times \Delta I_L} \quad (EQ 16)$$

$$P_{RS} = I_{L-rms}^2 \times R_S \times D \quad (EQ 17)$$

Note: Low inductance and specifically designed current sensing resistors should be used, e.g. Stackpole Electronics CSR/CSRN series of sensing resistors with less than 0.2nH (typ.).

8.1.9 Compensation Network

For typical use cases a compensation network should be implemented by C10, C11 and R11 for 2D mode and optional by different component values C12, C13, R13 for 3D mode (see Figure 18 on page 10).

A typical choice for values of the compensation network is C10 = 100pF, C11 = 10nF, R11 = 100KΩ. Use these values as initial choice and evaluate the transient response of the system to verify the behavior at output load change. To be able to do a different compensation for 3D mode, a second pin COMP_3D is available. If no separate compensation for 3D mode is necessary, PINs COMP_2D and COMP_3D can be connected to one common compensation network.

8.2 Buck Converter

The buck converter of the AS1390 is working with high-efficiency at a constant-frequency. The buck converter is optimized to supply a μC and with a fixed output voltage of 5V.

The buck converter is working as soon as the AS1390 is powered-up but offers an automatic power save mode. The highly efficient duty cycle provides low dropout operation, which reduces the power consumption of the system.

8.3 Overvoltage Protection (OVP)

An overvoltage condition is detected when the feedback voltage is higher than the skip threshold (1.28V typ.). The device is then entering the skip mode. Meaning the next pulse will be skipped and in the next cycle the overvoltage check is done again.

8.4 Overcurrent Protection (OCP)

An overcurrent comparator is monitoring the output current via the sense pin. If an overcurrent condition occurs the transistor will be switched off immediately. After the overcurrent condition is removed the device is returning to normal operation again.

8.5 Overtemperature Protection (OTP)

As soon as the junction temperature reaches approximately 140°C the AS1390 goes in thermal shutdown. In this mode the internal transistors are turned off. The device will power up again, as soon as the temperature falls below +110°C again.

9 Application Information

9.1 Typical Application

Figure 22. Typical Application

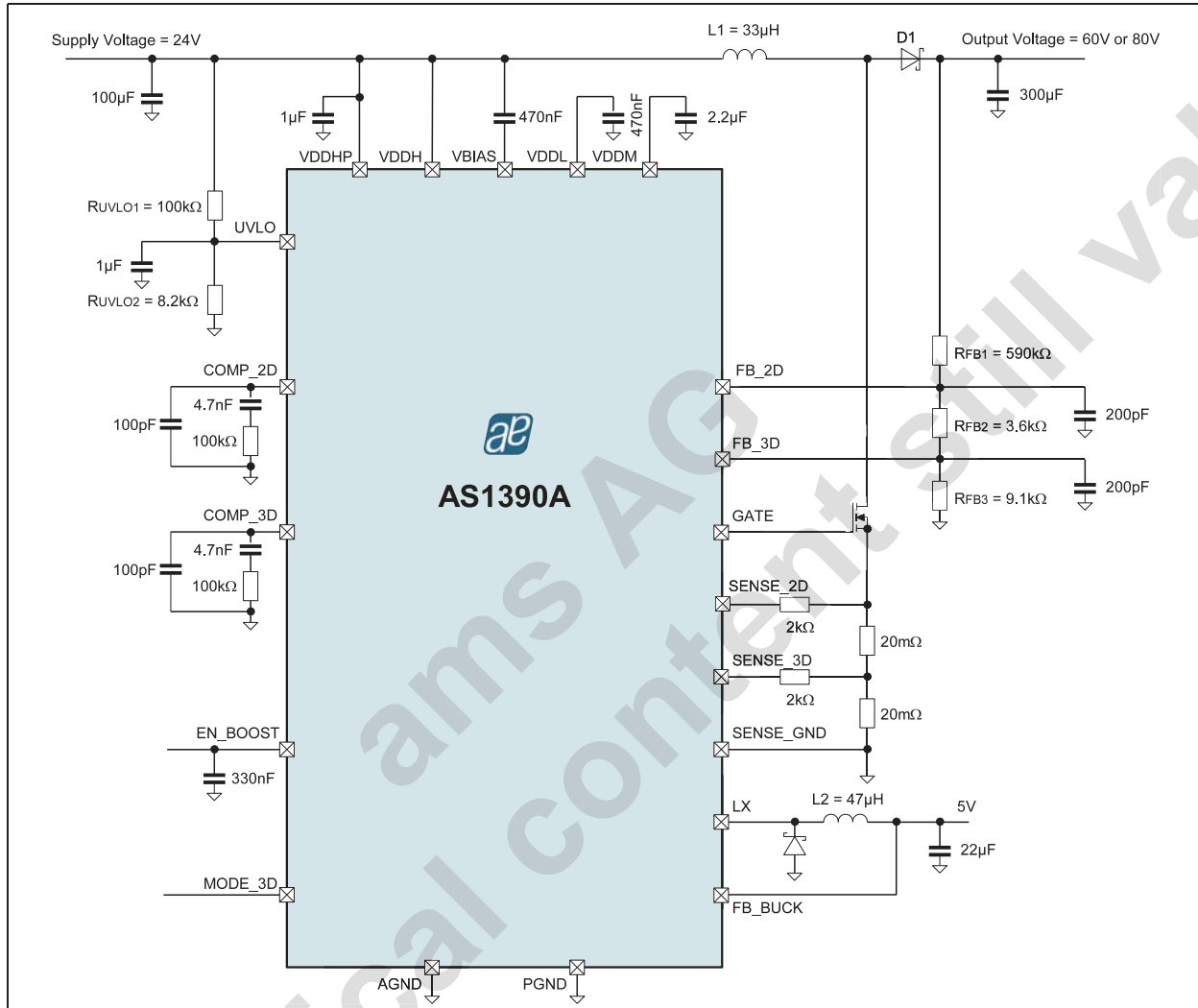

9.2 Recommended external Components

In order to reach the highest efficiency and best performance of the device we recommend to use the following external components.

For the capacitors and resistors standard available components can be used. Depending on the desired voltage and the current special inductors and transistors should be used to guarantee best performance for high current and high voltage operation. For the transistor we recommend the SIR432DP from Vishay Siliconix (www.vishay.com) for the Inductors see Table 4.

Table 4. Recommended Inductors

Part Number	L	DCR	Current Rating	Dimensions (L/W/T)	Manufacturer
74435573300	33µH	22mΩ	8.5A	18.3x18.2x8.9mm	Würth Elektronik www.we-online.de
VLCF4020T-470MR39	47µH	849mΩ	0.39A	4.0x4.0x2.0mm	TDK www.tdk.com

10 Package Drawings and Markings

Figure 23. 20-Pin QFN (4x4mm) Marking

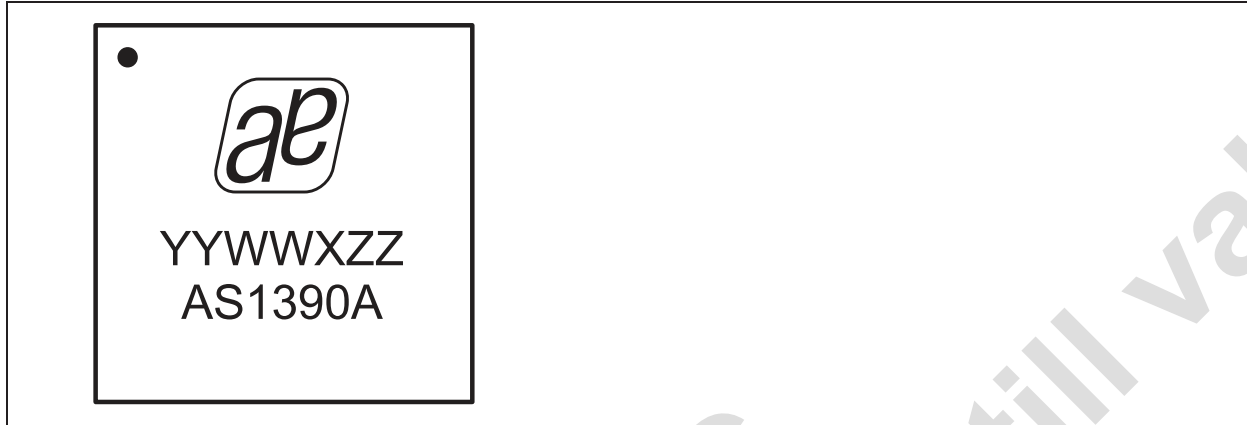

Figure 24. 16-pin SOIC Marking

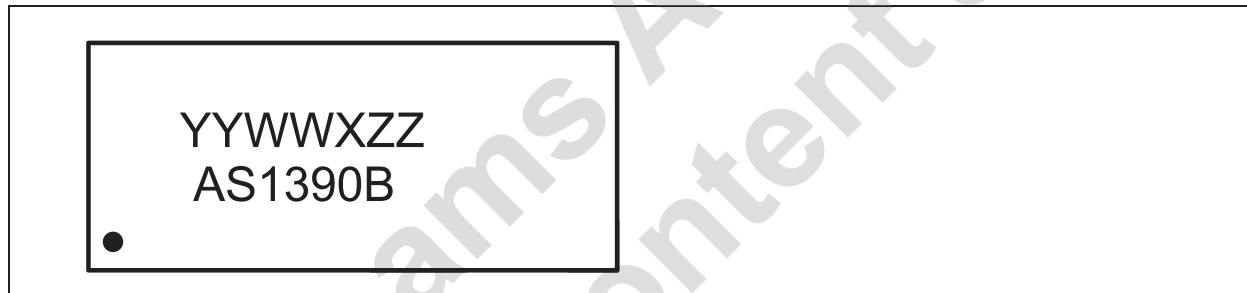

Table 5. Packaging Code YYWWXZZ

YY	WW	X	ZZ
last two digits of the current year	manufacturing week	plant identifier	free choice / traceability code

Figure 25. 20-Pin QFN (4x4mm) Package

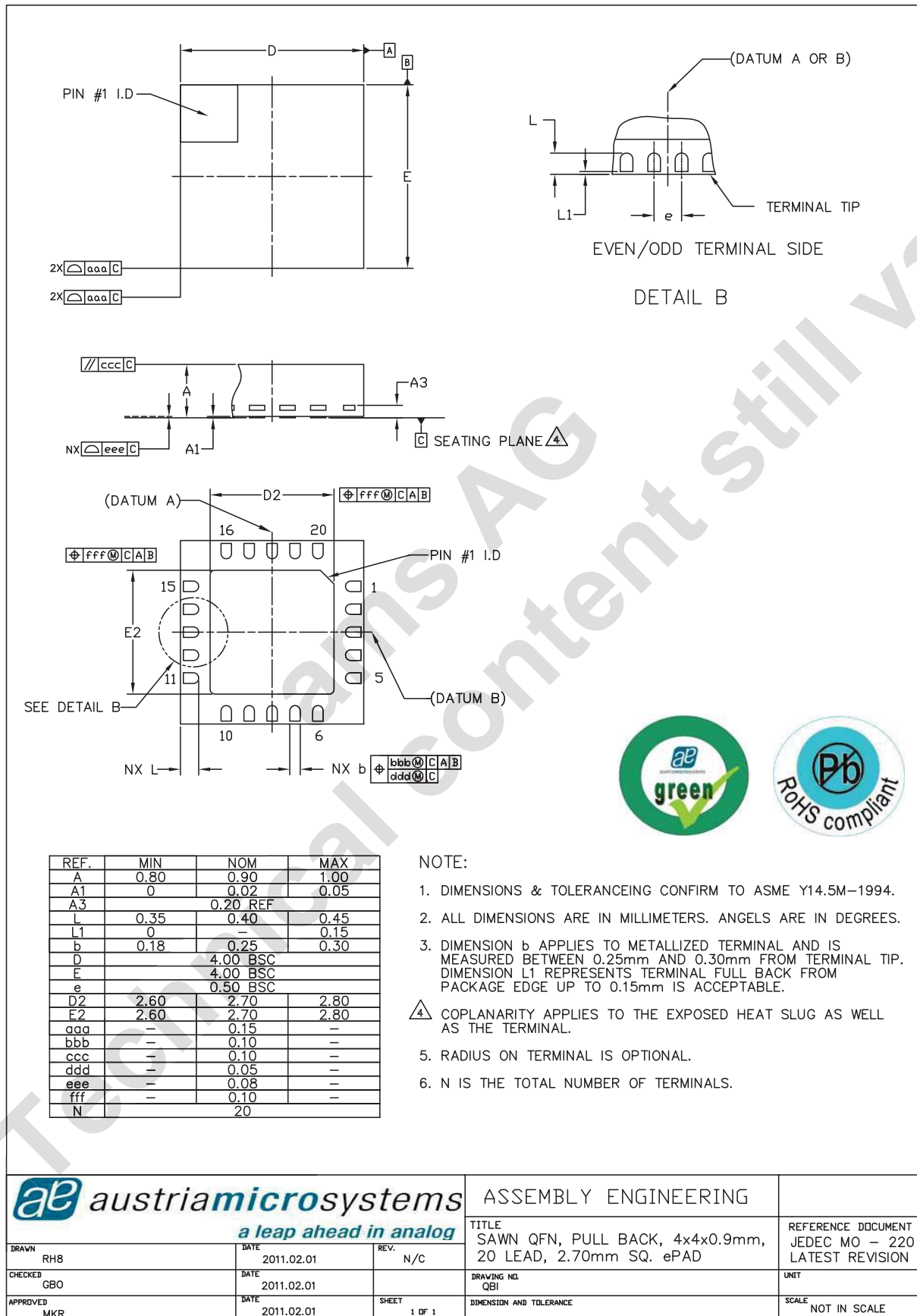
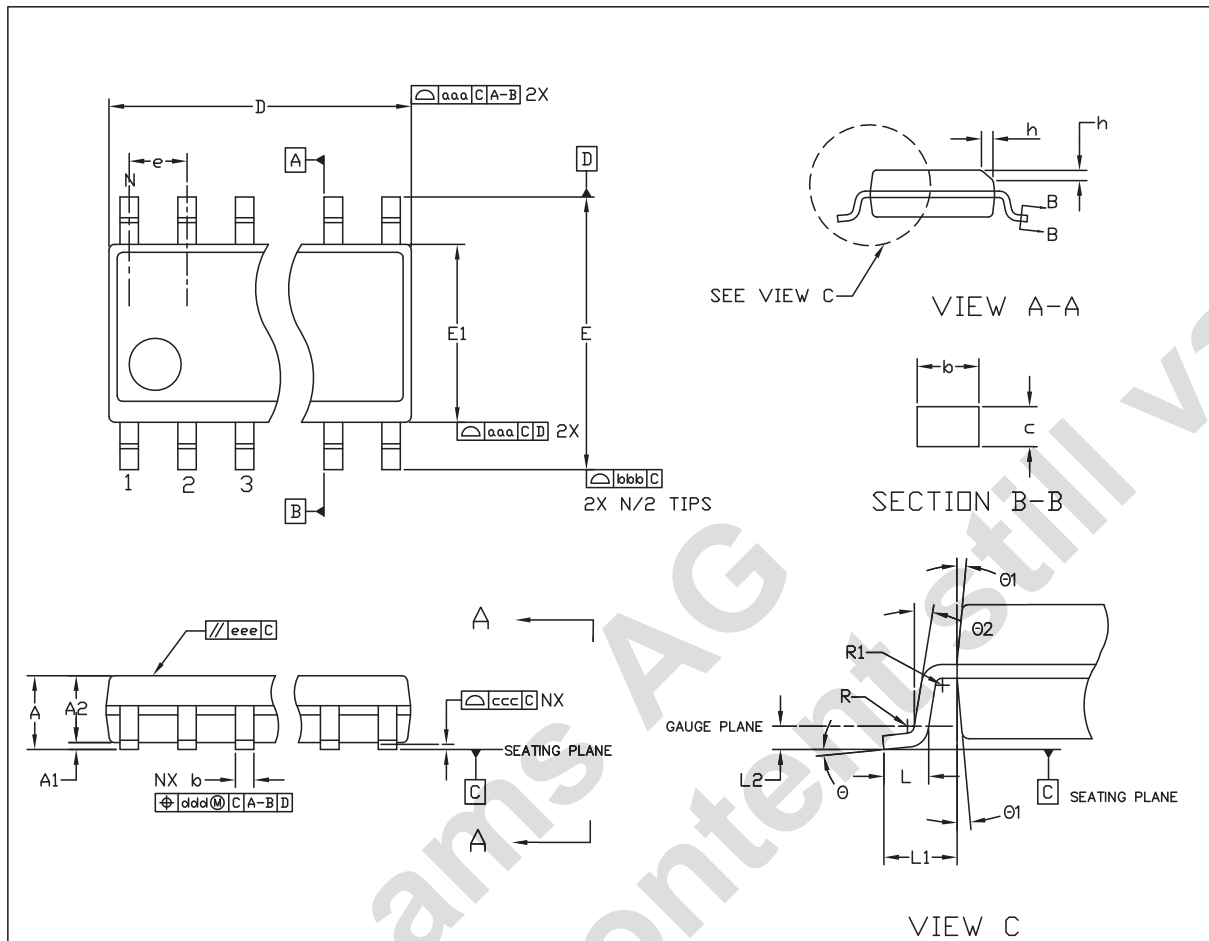

Figure 26. 16-pin SOIC Package



REF.	MIN	NOM	MAX
A	—	—	1.75
A1	0.10	—	0.25
A2	1.25	—	—
b	0.31	—	0.51
c	0.17	—	0.25
D	—	9.90 BSC	—
E	—	6.00 BSC	—
E1	—	3.90 BSC	—
e	—	1.27 BSC	—
L	0.40	—	1.27
L1	—	1.40 REF	—
L2	—	0.25 BSC	—
R	0.07	—	—
R1	0.07	—	—
h	0.25	—	0.50
theta	0°	—	8°
theta1	5°	—	15°
theta2	0°	—	—
aaa	—	0.10	—
bbb	—	0.20	—
ccc	—	0.10	—
ddd	—	0.25	—
eee	—	0.10	—
fff	—	0.15	—
ggg	—	0.15	—
N	—	16	—



NOTE:

1. DIMENSIONS & TOLERANCEING CONFIRM TO ASME Y14.5M-1994.
2. ALL DIMENSIONS ARE IN MILLIMETERS. ANGELS ARE IN DEGREES.

austriamicrosystems <i>a leap ahead in analog</i>			ASSEMBLY ENGINEERING	
DRAWN RH8	DATE 2010.09.21	REV. N/C	TITLE SOIC 150MIL, 16 LEAD	REFERENCE DOCUMENT JEDEC MS - 012 LATEST REVISION
CHECKED GBO	DATE 2010.09.21		DRAWING NO. JUR	UNIT
APPROVED MKR	DATE 2010.09.21	SHEET 1 OF 1	DIMENSION AND TOLERANCE	SCALE NOT IN SCALE

11 Ordering Information

The device is available as the standard products listed below.

Table 6. Ordering Information

Ordering Code	Marking	Description	Delivery Form	Package
AS1390A-BQFT	AS1390A	High Power Boost Controller and Buck Converter for LED Backlight	Tape and Reel	20-Pin QFN (4x4mm)
AS1390B-BSOT*	AS1390B	High Power Boost Controller and Buck Converter for LED Backlight	Tape and Reel	16-pin SOIC

*) on request

Note: All products are RoHS compliant and austriamicrosystems green.
Buy our products or get free samples online at ICdirect: <http://www.austriamicrosystems.com/ICdirect>

Technical Support is found at <http://www.austriamicrosystems.com/Technical-Support>

For further information and requests, please contact us <mailto:sales@austriamicrosystems.com>
or find your local distributor at <http://www.austriamicrosystems.com/distributor>

Copyrights

Copyright © 1997-2012, austriamicrosystems AG, Tobelbaderstrasse 30, 8141 Unterpremstaetten, Austria-Europe. Trademarks Registered ®. All rights reserved. The material herein may not be reproduced, adapted, merged, translated, stored, or used without the prior written consent of the copyright owner.

All products and companies mentioned are trademarks or registered trademarks of their respective companies.

Disclaimer

Devices sold by austriamicrosystems AG are covered by the warranty and patent indemnification provisions appearing in its Term of Sale. austriamicrosystems AG makes no warranty, express, statutory, implied, or by description regarding the information set forth herein or regarding the freedom of the described devices from patent infringement. austriamicrosystems AG reserves the right to change specifications and prices at any time and without notice. Therefore, prior to designing this product into a system, it is necessary to check with austriamicrosystems AG for current information. This product is intended for use in normal commercial applications. Applications requiring extended temperature range, unusual environmental requirements, or high reliability applications, such as military, medical life-support or life-sustaining equipment are specifically not recommended without additional processing by austriamicrosystems AG for each application. For shipments of less than 100 parts the manufacturing flow might show deviations from the standard production flow, such as test flow or test location.

The information furnished here by austriamicrosystems AG is believed to be correct and accurate. However, austriamicrosystems AG shall not be liable to recipient or any third party for any damages, including but not limited to personal injury, property damage, loss of profits, loss of use, interruption of business or indirect, special, incidental or consequential damages, of any kind, in connection with or arising out of the furnishing, performance or use of the technical data herein. No obligation or liability to recipient or any third party shall arise or flow out of austriamicrosystems AG rendering of technical or other services.



Contact Information

Headquarters

austriamicrosystems AG
Tobelbaderstrasse 30
A-8141 Unterpremstaetten, Austria

Tel: +43 (0) 3136 500 0
Fax: +43 (0) 3136 525 01

For Sales Offices, Distributors and Representatives, please visit:

<http://www.austriamicrosystems.com/contact>