

**CONTACT ORIENTATION ON ROLL**

**NOTES : (UNLESS OTHERWISE SPECIFIED)**

- 1. MATERIAL :**
  - 1.1. CONTACT BODY : COPPER ALLOY.**
  - 1.2. OUTER SPRING : STAINLESS STEEL.**
- 2. SPECIFICATIONS :**
  - 2.1 CURRENT RATING : 23A MAX.**
  - 2.2 TERMINATION TYPE : CRIMPING.**
  - 2.3 WIRE RANGE : 14~12AWG.**
  - 2.4 WIRE INSULATION DIA(MAX) :  $\phi$ 4.3mm.**
- 3. RoHS COMPLIANT.**
- 4. ALL DIMENSIONS ARE FOR REFERENCE USE ONLY.**

P/N	CONTACT PLATING(MATING AREA)
SS12A1T	TIN PLATING OVER NICKEL.
SS12A1F	GOLD FLASH PLATING OVER NICKEL.
SS12A1G10	10 $\mu$ "GOLD PLATING OVER NICKEL.
SS12A1G15	15 $\mu$ "GOLD PLATING OVER NICKEL.
SS12A1G30	30 $\mu$ "GOLD PLATING OVER NICKEL.

REVISIONS					
REV	ECO	DESCRIPTION	DATE	BY	APPR
B1	-	RELEASED DRAWING	JAN-18-2014	ARROW	TOMMY
B2	-	UPDATE DRAWING	NOV-09-2016	FLAN	TOMMY

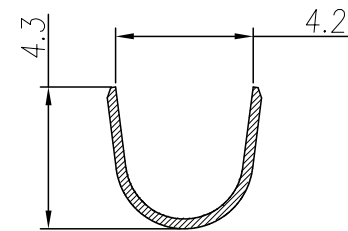

SECTION B-B

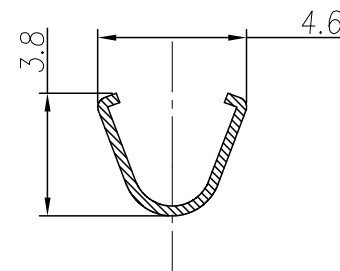

SECTION A-A

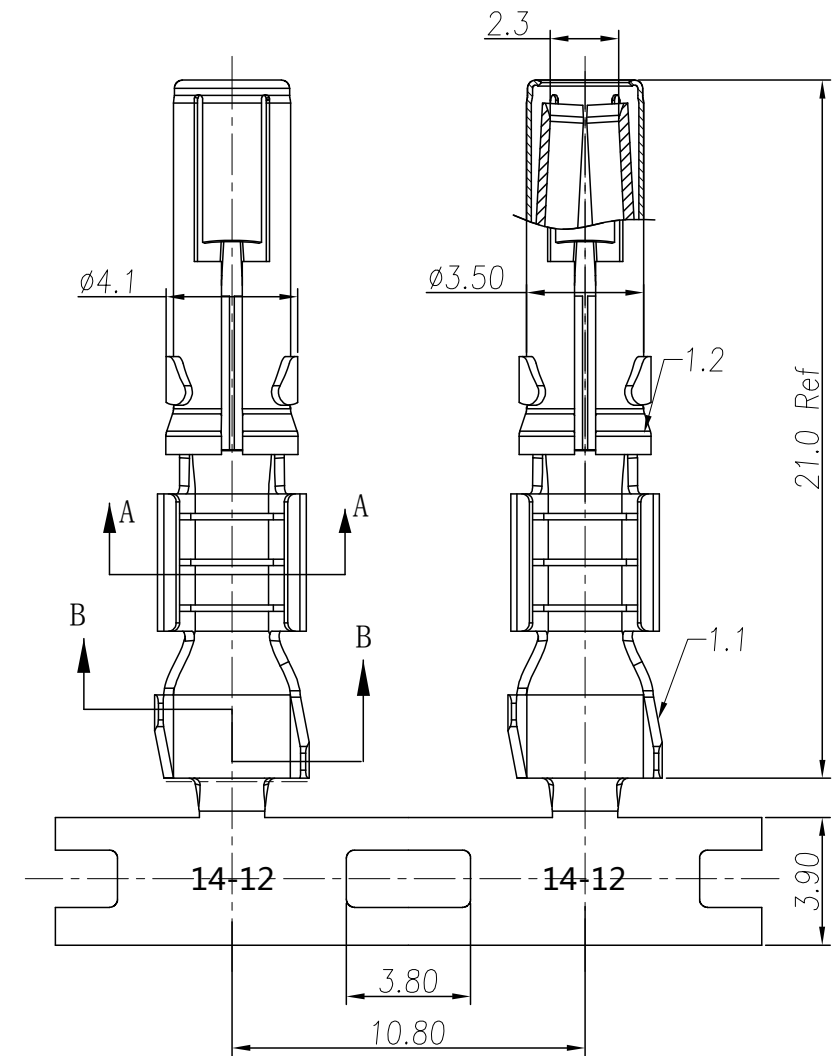

TITLE: ECO-MATE, SOCKET CONTACT, STAMPED, 14-12AWG, 2.5mm  
 DWG NO: SS12A1XX  
 REV: B2  
 SHEET: 1 OF 1

QUANTITY	PART NUMBER	DESCRIPTION	ITEM
<b>MATERIALS LIST</b>			
UNLESS OTHERWISE SPECIFIED 1) All dimensions are in metric(mm). 2) Tolerances are as follows: 1 PL DEC $\pm 0.30$ 2 PL DEC $\pm 0.15$ 3 PL DEC $\pm 0.08$ Fractions $\pm 1/64$ Angles $\pm 1^\circ$ 3) Note reference = $\triangle x$		<b>SIGNATURES</b> DRAWN: FLAN CHECKED: TOD ENGINEER: APPROVAL: TOMMY DATE: Nov-08-2016 Nov-08-2016	<b>Amphenol</b> Sine Systems - www.amphenol-sine.com 44724 Morley Drive Clinton Township, MI 48036
MATERIAL SPECIFICATIONS: PROCESS SPECIFICATIONS: NEXT ASSY:		CUSTOMER: THIS DRAWING IS SUPPLIED FOR INFORMATION ONLY. DESIGN FEATURES, SPECIFICATIONS AND PERFORMANCE DATA SHOWN HEREON ARE THE PROPERTY OF THE AMPHENOL CORPORATION. NO RIGHTS OF REPRODUCTION ARE IMPLIED. ALL DIMENSIONS ARE SUBJECT TO NORMAL MANUFACTURING VARIATIONS.	ECO-MATE, SOCKET CONTACT, STAMPED, 14-12AWG, 2.5mm CONTACT SIZE: B C- DWG NO: SS12A1XX REVISION: B2 SCALE: NONE SHEET 1 OF 1