

REVISIONS					
P	LTR	DESCRIPTION	DATE	DWN	APVD
M3		REVISED PER ECN-22-156403	03JUN2022	RK	CSD

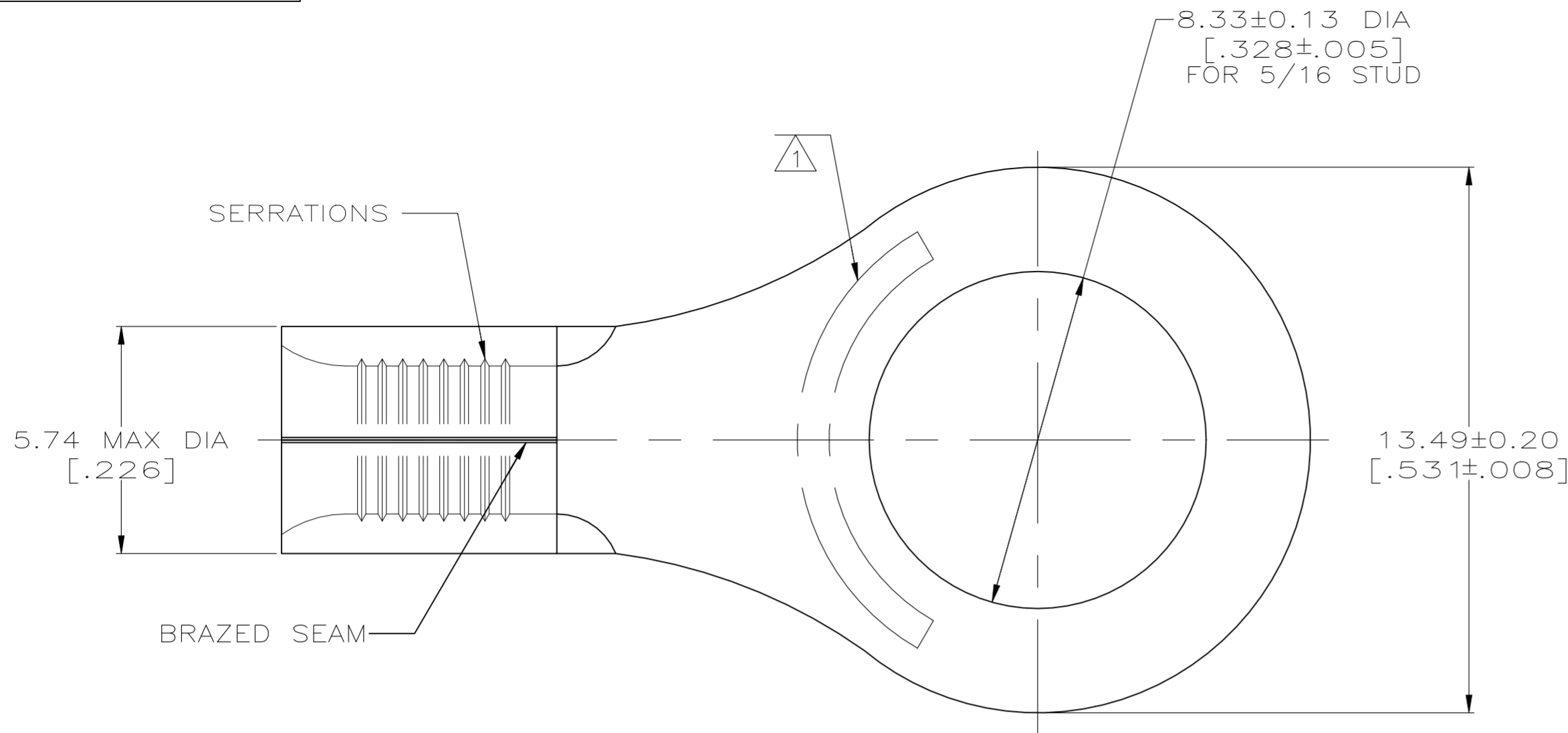

AMP WIRE RANGE	E13288 Listed
12-10 AWG SOLID OR STRANDED	12-10 AWG STRANDED
LR7189 Certified	MILITARY P/N AND CLASS
12-10 AWG SOLID OR STRANDED	MS20659-106 CLASS 1 P/N 33459

1 STAMP AMP 12-10* APPROX AS SHOWN

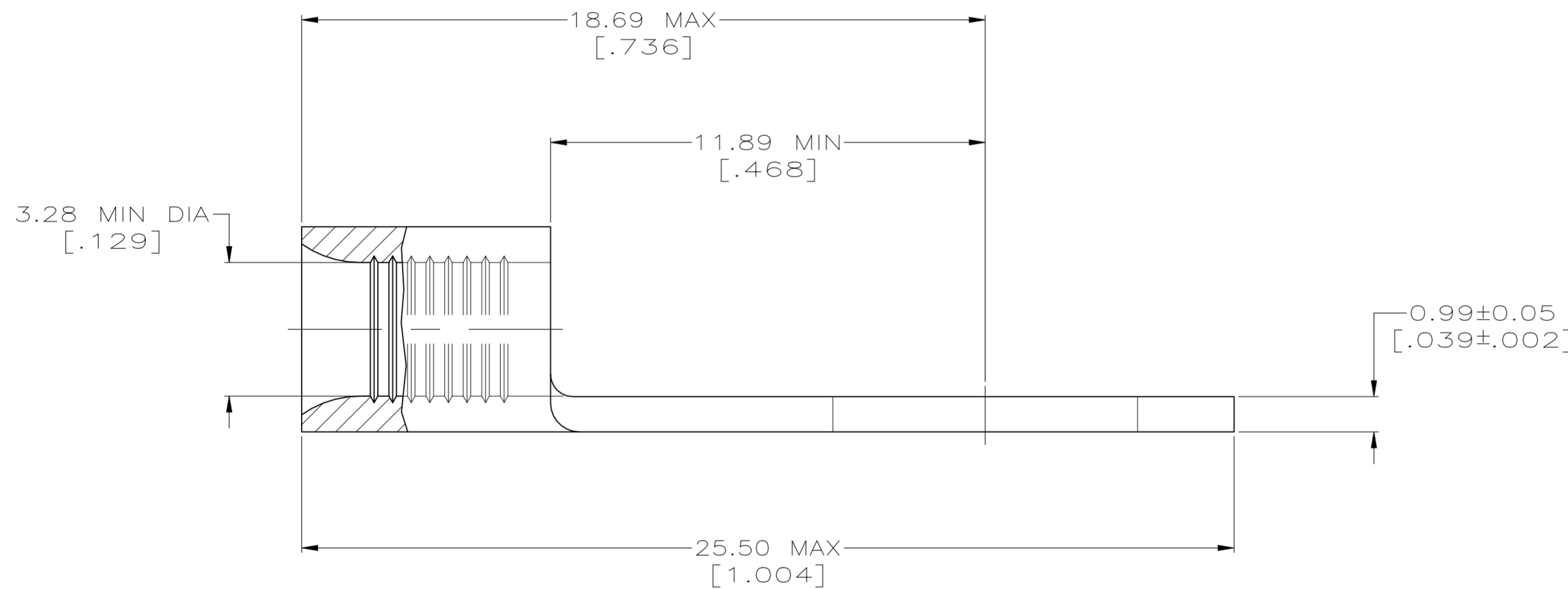

QUANTITY	PACKAGE TYPE	FINISH	PART NO
----	LOOSE PIECE	UNPLATED, FULLY ANNEALED	33459-4
50	LOOSE PIECE BOX 33459	TIN PLATE 0.00254[.000100] MIN THK PER MIL-T-10727	8-33459-2
OBSOLETE	LOOSE PIECE	UNPLATED	2-33459-9
2500	33459 ON TAPE	TIN PLATE 0.00254[.000100] MIN THK PER MIL-T-10727	2-33459-6
----	LOOSE PIECE	TIN PLATE 0.00254[.000100] MIN THK PER MIL-T-10727	33459

AMP INCORPORATED CUSTOMER SERVICE SYSTEMS		MAX RECOMMENDED OPERATING TEMPERATURE: 170° C MAX
FOR ADDITIONAL PRODUCT INFORMATION OR COPIES OF DRAWINGS AND TECHNICAL DOCUMENTS	PRODUCT INFORMATION CENTER 1-800-522-6752	VOLTAGE RATING: NOT APPLICABLE
FOR APPLICATION TOOLING INFORMATION	TOOLING ASSISTANCE CENTER 1-800-722-1111	WIRE CROSS SECTIONAL AREA RANGE: 2.62-6.64mm ² [5,180-13,100] CIR MILS SOLID OR STRANDED
FOR ORDER ENTRY	1-800-526-5142	

THIS DRAWING IS A CONTROLLED DOCUMENT.		DWN TA BRINKMAN 3-17-93	TE Connectivity	
DIMENSIONS: mm[INCHES]		CHK DA PATTERSON 3-17-93	NAME DE MILLER 3-17-93	
TOLERANCES UNLESS OTHERWISE SPECIFIED:		APVD DE MILLER 3-17-93	PRODUCT SPEC	
0 PLC ± -		APPLICATION SPEC		
1 PLC ± -		WEIGHT		
2 PLC ± -		SIZE A2		
3 PLC ± -		CAGE CODE 00779		
4 PLC ± -		DRAWING NO C=33459		
ANGLES ± -		RESTRICTED TO		
FINISH SEE TABLE		SCALE 8:1		
MATERIAL COPPER PER ASTM B-152 ANNEALED		SHEET 1 OF 1		
		REV M3		