

THIS DRAWING CONTAINS INFORMATION PROPRIETARY TO RF INDUSTRIES,
 ANY UNAUTHORIZED USE OF THIS DRAWING IS EXPRESSLY PROHIBITED
 WITHOUT WRITTEN PERMISSION FROM RF INDUSTRIES.
 ANY VIOLATION IS PUNISHABLE UNDER U.S. COPYRIGHT LAWS.

ALL DIMENSIONS ARE REFERENCE ONLY

PART NO.		RFU-545		
REV	DESCRIPTION	DWN	DATE	APPROVED
A	ENGINEERING RELEASE	CJ	10/28/91	J. BENZ
B	THREAD CHANGE	CJ	4/3/92	J. BENZ
C	CHANGE PIN TO SILVER \ DETAIL DIELECTRIC & PIN DIMS	KMM	11/11/94	R. RICE
D	REMOVE P/N FROM CONNECTOR / UPDATE FORMAT & SPECS	CZS	6/12/03	R. RICE

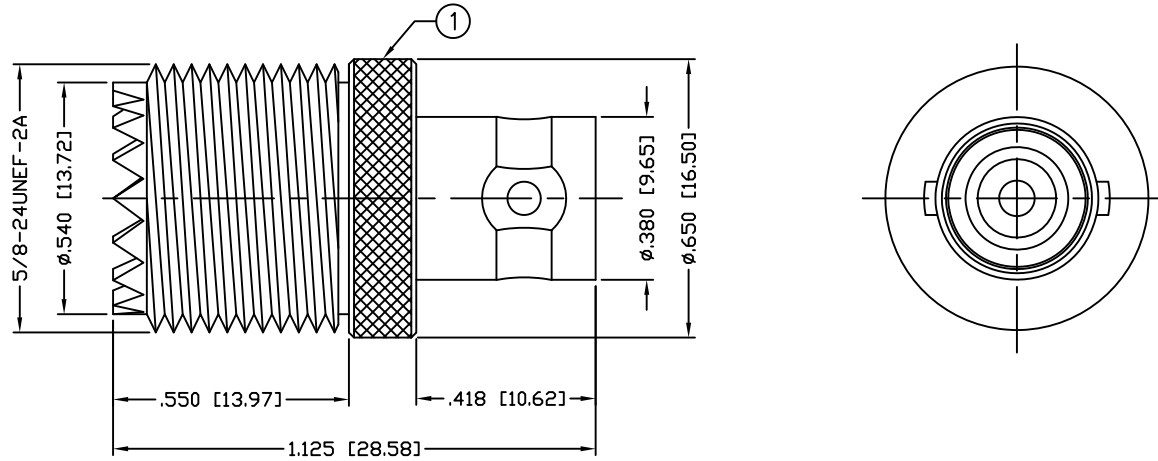

SPECIFICATIONS:

IMPEDANCE: NON CONSTANT
 FREQUENCY RANGE: 0-300 MHz
 WORKING VOLTAGE: 500 V rms max. @ sea level

1	BODY	1	BRASS	NICKEL, 80μ ^p	000486	
2	CONTACT	1	BRASS	SILVER, 5μ		
3	INSULATOR	1	DELTRIN	---		
4	INSULATOR	1	DELTRIN	---		
5	PRESS WASHER	1	BRASS	NICKEL, 80μ ^p		
6						
7						
8						
9						
10					DRAWN C. ZUNIGA	
11					6/12/03	
12					CHECKED	
13						
14					ORJ DRAWN C. JONES	
					10/28/91	
#	DESCRIPTION	QTY	MATERIAL	FINISH	APPROVALS	DATE

UNLESS OTHERWISE SPECIFIED:
 1. REMOVE ALL BURRS
 2. BREAK ALL CORNERS & EDGES .005 R. MAX.
 3. CHAMFER 1ST & LAST THREADS 45°
 4. SURFACE ROUGHNESS 63 FINISH MIL-STD-10
 5. DIAMETERS ON COMMON CENTERS TO BE CONCENTRIC WITHIN .002 T.I.R.
 6. ALL DIMENSIONS ARE AFTER PLATING.

DIMENSIONS ARE IN INCHES AND [MILLIMETERS]
 UNLESS OTHERWISE NOTED TOLERANCES ARE:
 DECIMALS DIAMETER
 .xxx±.003 [.08] .xxx±.001 [.03]
 .xx±.005 [.13] .xx±.003 [.08]

RF connectors
 DIVISION OF RF INDUSTRIES, LTD.
 7610 MIRAMAR RD
 SAN DIEGO, CA 92126
 (858) 549-6340
 (858) 549-6345 FAX

UHF JACK TO BNC JACK
 ADAPTER

SIZE	CABLE GROUP	DWG NO.	REV
A	N/A	RFU-545	D
SCALE: NTS		CAD FILE OUTLINE	SHEET 1 OF 1