

DESCRIPTION

The EV2604DQ-00A is an evaluation board for the MP2604, a linear, high-performance single cell Li-Ion battery charger. By integrating high voltage input protection into the charger IC, the MP2604 can tolerate an input surge up to 28V.

The MP2604 features constant current (CC) and constant voltage (CV) charging modes with programmable charge currents (200mA to 1A), programmable battery full threshold, thermal protection, battery temperature monitoring and reverse current blocking. The device also provides AC adapter power good and charge status indications to the system.

ELECTRICAL SPECIFICATIONS

Parameter	Symbol	Value	Units
Input Voltage	V _{IN}	5	V
Charging Current	I _{CHG}	0.8	A
Charging Voltage	V _{BAT}	4.2	V

FEATURES

- Input Surge up to 28V
- Adapter or USB Input
- Programmable Charge Current: 200mA to 1A
- AC Adapter Power Good Indicator
- Charge Status Indicator
- Programmable Charge Termination Current Threshold
- Fully Assembled and Tested

APPLICATIONS

- Cell Phones
- MP3 Players
- Smart Phones
- PDAs
- Digital Cameras

"MPS" and "The Future of Analog IC Technology" are Registered Trademarks of Monolithic Power Systems, Inc.

EV2604DQ-00A EVALUATION BOARD

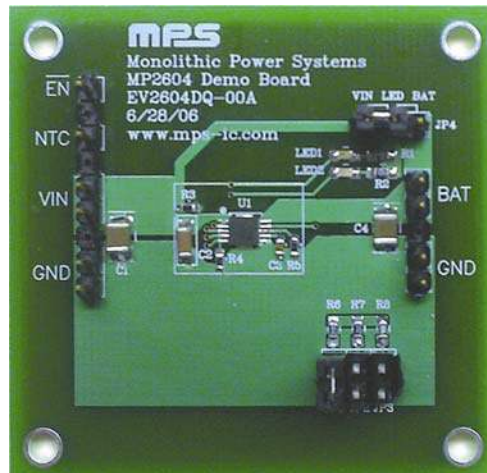

(L x W x H) 2.0" x 1.9" x 0.6"
5.1cm x 4.8cm x 1.5cm

Board Number	MPS IC Number
EV2604DQ-00A	MP2604DQ

EVALUATION BOARD SCHEMATIC

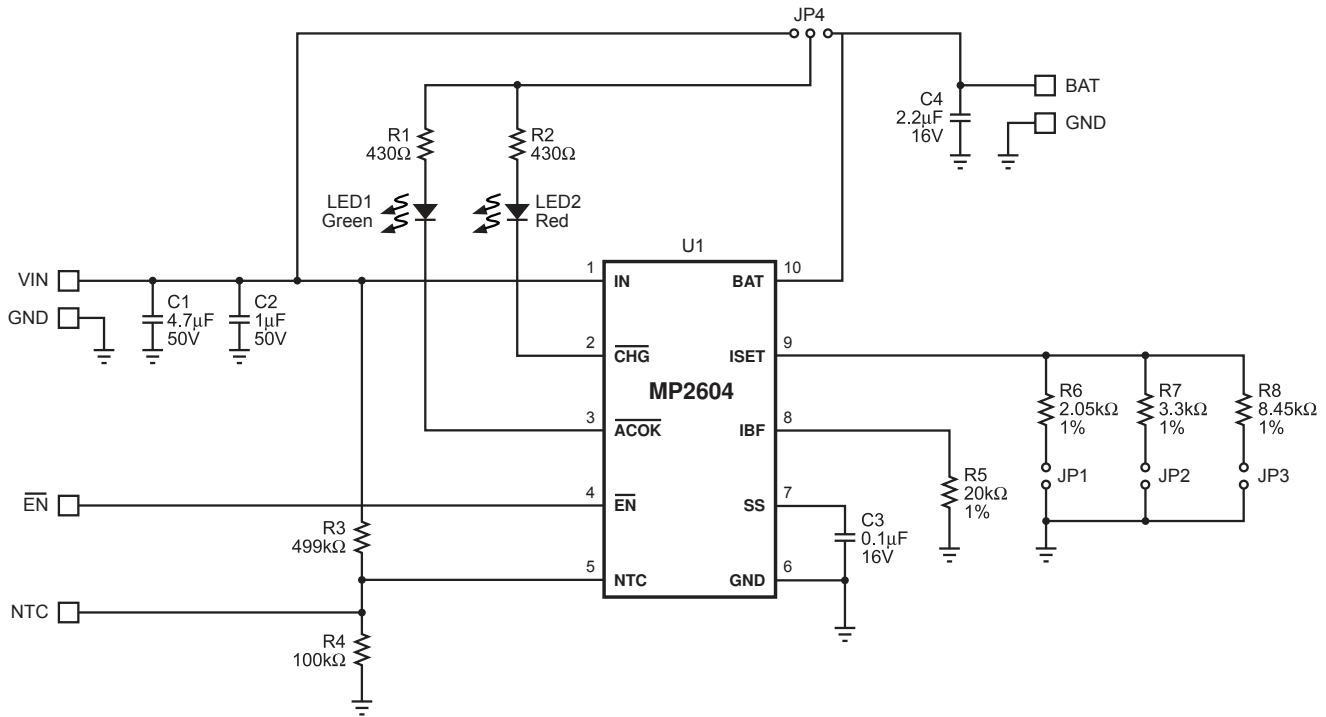

EV2604DQ-00A BILL OF MATERIALS

Qty	Ref	Value	Description	Package	Manufacturer P/N
1	C1	4.7µF	Ceramic Capacitor, 50V, X7R	1210	Murata: GRM32ER71H475KA88L Holystone: C1210B475M035T
1	C2	1µF	Ceramic Capacitor, 50V, X7R	1206	TDK: C3216X7R1H105K
1	C3	0.1µF	Ceramic Capacitor, 16V, X7R	0603	TDK: C1608X7R1C104K
1	C4	2.2µF	Ceramic Capacitor, 16V, X7R	1210	Murata: GRM32MR71C225MC01L
3	JP1, JP2, JP3		2-Pin Connector Header, 0.100"		Sullins: PTC02SAAN
1	JP4		3-Pin Connector Header, 0.100"		Sullins: PTC03SAAN
1	LED1		Green LED, Surface Mount	0603	Lumex: SML-LX0603GW-TR
1	LED2		Red LED, Surface Mount	0603	Lumex: SML-LX0603IW-TR
2	R1, R2	430Ω	Resistor, 5%	0603	Panasonic: ERJ-3GEYJ431V
1	R3	499kΩ	Resistor, 1%	0603	Panasonic: ERJ-3EKF4993V
1	R4	100kΩ	Resistor, 1%	0603	Panasonic: ERJ-3EKF1003V

EV2604DQ-00A BILL OF MATERIALS (continued)

Qty	Ref	Value	Description	Package	Manufacturer P/N
1	R5	20kΩ	Resistor, 1%	0603	Panasonic: ERJ-3EKF2002V
1	R6	2.05kΩ	Resistor, 1%	0603	Yageo: 9C06031A2051FKHFT
1	R7	3.3kΩ	Resistor, 1%	0603	Yageo: 9C06031A3301FKHFT
1	R8	8.45kΩ	Resistor, 1%	0603	Panasonic: ERJ-3EKF8451V
1	U1		Linear Charger	QFN10	MPS: MP2604DQ

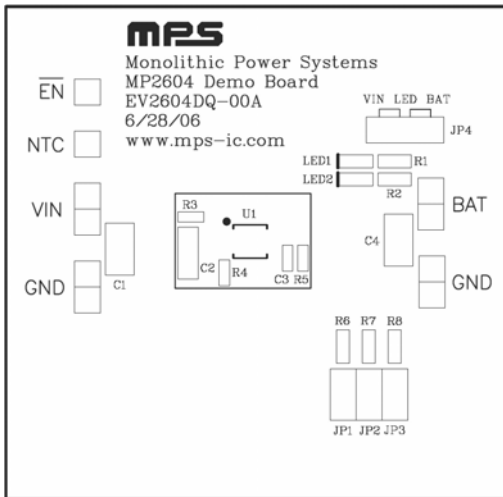
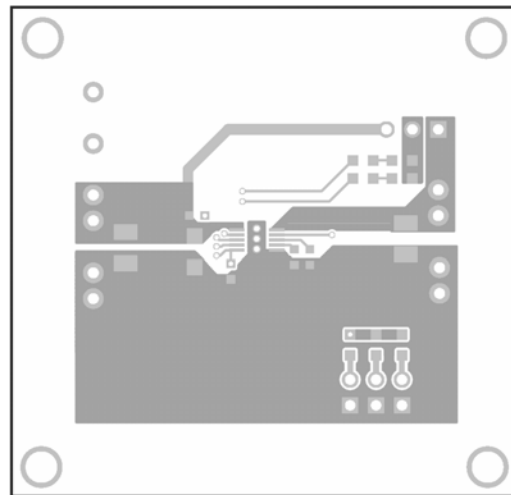
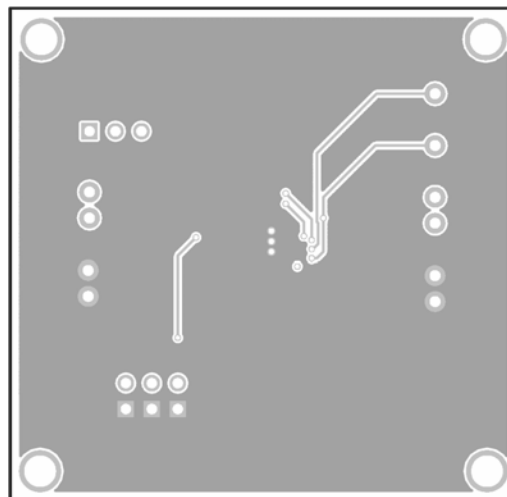
PRINTED CIRCUIT BOARD LAYOUT

Figure 1—Top Silk Layer

Figure 2—Top Layer

Figure 3—Bottom Layer

QUICK START GUIDE

The output voltage on this board is preset to 4.2V (for a single cell battery). The board layout accommodates most commonly used capacitors.

The LEDs are power indicators. When LED1 is on, the 5V input is present (LED1 is off when the input is disconnected). When LED2 is on, the battery is charging, and when the battery is full or there is no battery connected, LED 2 will turn off.

1. Set the charge current I_{CHG} using the jumpers JP1, JP2 and JP3 per the following table:

JP1	JP2	JP3	I_{CHG}
X		X	1000mA
X			800mA
	X	X	700mA
	X		500mA
		X	200mA

Where “X” indicates a connection.

2. Attach the positive and negative ends of the load to the VOUT and GND pins, respectively.
3. Attach the input voltage ($V_{IN}=5V$) and the input ground to the VIN and GND pins, respectively.
4. Set the battery full threshold I_{FB} using R5:

$$I_{FB} = \frac{1700}{R5(\Omega)}$$

5. Set the LED1 and LED2 input power from the VIN side or BAT side using JP4.

NOTICE: The information in this document is subject to change without notice. Users should warrant and guarantee that third party Intellectual Property rights are not infringed upon when integrating MPS products into any application. MPS will not assume any legal responsibility for any said applications.