



Z8 Encore! XP[®] Microcontroller Family

***Z8F04A08100KIT
Z8 Encore! XP[®] 4K Series
8-Pin Development Kit***

User Manual

UM018702-0505

**Z8F04A08100KIT Development Kit
User Manual**



This publication is subject to replacement by a later edition. To determine whether a later edition exists, or to request copies of publications, contact:

ZiLOG Worldwide Headquarters

532 Race Street
San Jose, CA 95126
Telephone: 408.558.8500
Fax: 408.558.8300
www.ZiLOG.com

Document Disclaimer

ZiLOG is a registered trademark of ZiLOG Inc. in the United States and in other countries. All other products and/or service names mentioned herein may be trademarks of the companies with which they are associated.

©2005 by ZiLOG, Inc. All rights reserved. Information in this publication concerning the devices, applications, or technology described is intended to suggest possible uses and may be superseded. ZiLOG, INC. DOES NOT ASSUME LIABILITY FOR OR PROVIDE A REPRESENTATION OF ACCURACY OF THE INFORMATION, DEVICES, OR TECHNOLOGY DESCRIBED IN THIS DOCUMENT. ZiLOG ALSO DOES NOT ASSUME LIABILITY FOR INTELLECTUAL PROPERTY INFRINGEMENT RELATED IN ANY MANNER TO USE OF INFORMATION, DEVICES, OR TECHNOLOGY DESCRIBED HEREIN OR OTHERWISE. Devices sold by ZiLOG, Inc. are covered by warranty and limitation of liability provisions appearing in the ZiLOG, Inc. Terms and Conditions of Sale. ZiLOG, Inc. makes no warranty of merchantability or fitness for any purpose Except with the express written approval of ZiLOG, use of information, devices, or technology as critical components of life support systems is not authorized. No licenses are conveyed, implicitly or otherwise, by this document under any intellectual property rights.



Table of Contents

Table of Contents	iii
List of Figures	v
Introduction	1
Kit Contents	1
Hardware	1
Software (on CD-ROM)	2
Documentation	3
System/Software Requirements	3
Supported Host System Configuration	3
Designing with the USB Smart Cable	4
Installation	5
Development Board	7
Introduction	7
Features	8
MCU	8
UART with IrDA Endec	9
Jumpers and Settings	10
DEMO Mode Jumper Settings	11
USER DEBUG Mode Jumper Settings	12
Switches S1, S2, and SW1	12
External Interface Headers JP1 and JP2	12
Use of Ceramic Resonator Y1	13
Schematic	15

**Z8F04A08100KIT Development Kit
User Manual**

iv





List of Figures

- Figure 1. Z8 Encore! XP® 4K Series 8-Pin Development Kit Contents
(Printed Quick Start Guide Not Shown)2
- Figure 2. Z8 Encore! XP® 4K Series 8-Pin Development Board7

**Z8F04A08100KIT Development Kit
User Manual**

vi





Introduction

The Z8 Encore! XP[®] 4K Series 8-pin MCU is part of the line of ZiLOG microcontroller products.

The Z8 Encore! XP[®] 4K Series 8-Pin Development Kit (Z8F04A08100KIT) enables users to become familiar with the hardware and software tools available with this product. This kit consists of the 4KB version of the Z8 Encore! Development board that supports and presents the features of the Z8 Encore! XP 4K Series 8-pin package. This kit allows users to begin writing application software and contains all supporting documents.

This manual acquaints users with the Z8 Encore! XP 4K Series 8-Pin MCU Development Kit, and gives instructions on setting up and using the tools to start building designs and applications.

Kit Contents

The Z8 Encore! XP 4K Series 8-Pin MCU Development Kit contains the following:

Hardware

- Z8 Encore! XP 4K Series 8-Pin Development board
- USB Smart Cable for PC to Z8 Encore! XP 4K Series 8-Pin Development board
- 5VDC power supply



Figure 1. Z8 Encore! XP® 4K Series 8-Pin Development Kit Contents (Printed Quick Start Guide Not Shown)

Software (on CD-ROM)

- ZDS II- Z8 Encore!® IDE with ANSI C-Compiler
- Sample code
- Document browser
- Acrobat Reader install program



Documentation

- Quick Start Guide (QS0043)
- Registration card
- Z8 Encore! XP 4K Series 8-pin technical documentation (on CD-ROM)
 - Development Kit User Manual
 - ZDS II - IDE User Manual
 - eZ8 CPU User Manual
 - Application notes

The sample code is installed with ZDS II and resides in the <installation directory>\samples in the user's disk drive.

The documentation can be installed by the user with the DemoShield interface or can be viewed on the CD-ROM using the DemoShield menus and a PDF reader. A copy of the Acrobat installer is provided on the CD-ROM and can be installed from the DemoShield install screen. After installing the documentation on the user's system Windows Explorer can be used to select any document to be viewed with your favorite PDF file viewer.

System/Software Requirements

IBM PC (or compatible computer) with the following minimum configurations:

Supported Host System Configuration

- Win98 Second Edition, Win2000 Service Pack 3, WinXP Professional Service Pack 1
- PentiumII/233MHz processor or higher up to Pentium IV, 2.8 GHz
- 96 MB RAM or more



- 25 MB hard disk space or more
- Super VGA video adapter
- CD-ROM
- One USB high-speed or full-speed port on the host chassis or a powered hub

Designing with the USB Smart Cable

The Z8 Encore! XP 4K Series 8-Pin Development Kit requires use of the USB Smart Cable (supplied). The Z8 Encore! Serial Smart Cable and associated TIM will not work with the Z8F04A08100KIT kit. When designing your target board and application:

- Your target design's debug interface must include a RESET pin.
- Your target application must allow the RESET pin to be pulled LOW.

Refer to the chip product specification, PS0228, for further details.



Installation

Follow the directions in the Quick Start Guide (QS0043) for software installation and setup of the Z8 Encore! XP 4K Series 8-Pin Development kit.

**Z8F04A08100KIT Development Kit
User Manual**

6



Development Board

Introduction

The Z8 Encore! XP[®] 4K Series 8-Pin Development board is a development and prototyping board for the Z8 Encore! XP 4K Series 8-Pin MCU. The board provides customers with a tool to evaluate features of Z8 Encore! XP 4K Series 8-Pin MCU, and to start developing an application before building the hardware.

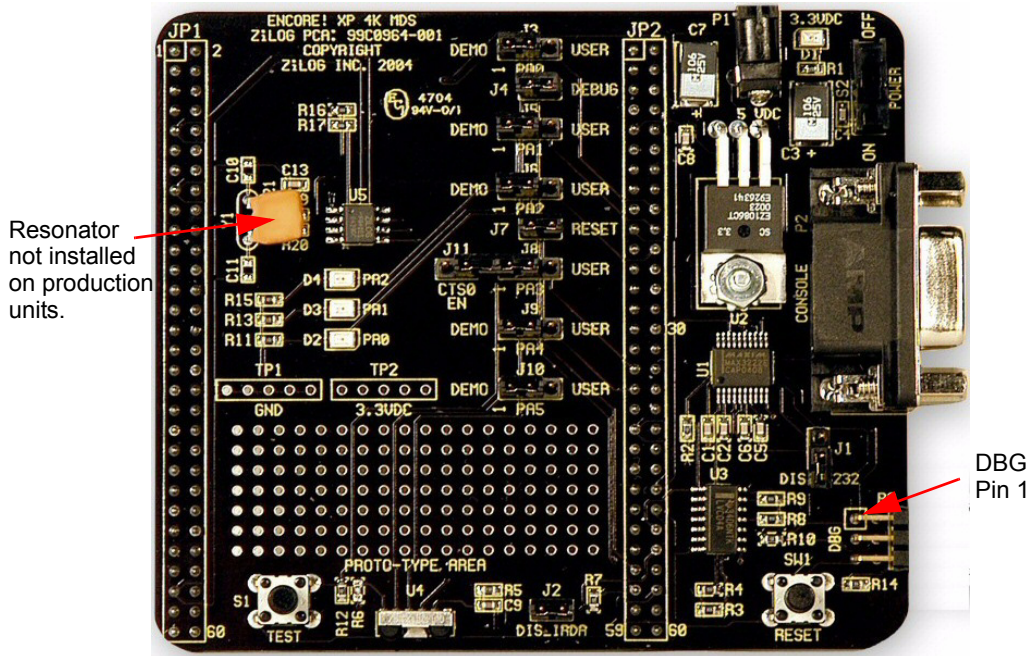

Figure 2. Z8 Encore! XP[®] 4K Series 8-Pin Development Board



Features

- Z8 Encore![®] MCU (8-pin SOIC)
- 3 LEDs
- RS-232 interface
- IrDA transceiver
- Two pushbuttons, RESET and TEST
- 5 VDC power connector
- On-Chip Debugger interface
- Prototyping area
- External interface connectors JP1 and JP2
- 2.7–3.6 V operating voltage with 5V-tolerant inputs

MCU

The Z8 Encore! XP 4K Series 8-pin MCU is member of a family of ZiLOG microcontroller products based upon the 8-bit eZ8 core CPU. The Flash in-circuit programming capability allows for faster development time and program changes in the field. The eZ8 core CPU is upward compatible with existing Z8[®] instructions. The rich peripheral set of the Z8 Encore! XP 4K Series makes it suitable for a variety of applications including motor control, security systems, home appliances, personal electronic devices, and sensors.

The Development board contains circuitry to support and present all the features of the Z8 Encore! XP 4K Series. The main features of the Z8 Encore! XP 4K Series 8-pin MCU are:

- eZ8 core CPU
- 4KB Flash memory with in-circuit programming capability



- 1KB register RAM
- 5-channel, 10-bit analog-to-digital converter (ADC)
- Full-duplex UART
- Infrared Data Association (IrDA)-compliant infrared encoder/decoder
- Two 16-bit timers with capture, compare, and PWM capability
- Watch-Dog Timer (WDT) with internal RC oscillator
- Six I/O pins
- Programmable priority interrupts
- On-Chip Debugger
- Voltage Brown-out Protection (VBO)
- Power-On Reset (POR)
- 2.7–3.6 V operating voltage with 5V-tolerant inputs
- Operating temperatures: $20^{\circ} \pm 10^{\circ} \text{C}$

For further information on the Z8 Encore![®] family of devices, consult the product specification, P/N PS0228, available for download from www.zilog.com.

UART with IrDA Endec

The Z8 Encore! XP 4K Series 8-pin MCU (component U5) contains a fully-functional, high-performance UART with Infrared Encoder/Decoder (ENDEC). The Infrared ENDEC is integrated with an on-chip UART allowing easy communication between the Z8 Encore! XP[™] 4K Series 8-pin MCU and IrDA transceivers. Infrared communication provides secure, reliable, low-cost, point-to-point communication between PCs, PDAs, cell phones, printers and other infrared enabled devices.



Jumpers and Settings

Table 1 provides information on jumper functions.

Table 1. Z8F04A08100KIT Jumper Functions

Jumper	State	Description	Default
J1*	OUT	Enables RS-232 interface	X
	IN	Disables RS-232 interface	
J2*	OUT	Enables IrDA interface	X
	IN	Disables IrDA interface	
J3	1-2	Connects U5 pin PA0 to Green LED D2	X
	2-3	Connects U5 pin PA0 to JP2 pin 18	
J4	OUT	Disconnects PA0 from debug pin	X
	IN	Connects PA0 to DBG pin 4 on ZDI port P3.	
J5	1-2	Connects U5 pin PA1 to yellow LED D3	X
	2-3	Connects U5 pin PA1 to JP2 pin 20	
J6	1-2	Connects U5 pin PA2 to red LED D4.	X
	2-3	Connects U5 pin PA2 to JP2 pin 22	



Table 1. Z8F04A08100KIT Jumper Functions

Jumper	State	Description	Default
J7	OUT	DEMO mode setting	X
	IN	Chip U5 resets when SW1 pressed	
J8	1-2	Connects U5 pin PA3 to J11 pin 1 (CTS0 EN)	X
	2-3	Connects U5 pin PA3 to JP2 pin 35	
J9	1-2	Connects U5 pin PA4 to RXD RS232 signal	X
	2-3	Connects U5 pin PA4 to JP2 pin 35	
J10	1-2	Connects U5 pin PA5 to TXD RS232 signal	X
	2-3	Connects U5 pin PA5 to JP2 pin 36	
J11	OUT	Disconnects PA3 from CTS0 RS232 signal	X
	IN	Connects PA3 to CTS0 RS232 signal	

Note: * These jumpers must not be OUT at the same time

The board has two modes of operation: DEMO and USER. Use DEMO mode to run the sample program included with the kit. Run the board in USER mode:

- When using the ZDI port to debug your code.
- When configuring the board to run your own prototype code.

DEMO Mode Jumper Settings

When running the board in DEMO mode, the following jumpers **MUST** be set:



J3 1-2
J4 OUT
J5 1-2
J6 1-2
J7 OUT
J8 1-2
J9 1-2
J10 1-2
J11 OUT

USER DEBUG Mode Jumper Settings

When running the board in USER DEBUG mode, the following jumpers **MUST** be set:

J3 OUT
J4 IN
J6 OUT
J7 IN

Switches S1, S2, and SW1

Switches S1, S2, and SW1 on the Z8 Encore! XP™ 4K Series 8-Pin Development board perform the following functions:

- S1 – Test switch
- S2 – Power ON/OFF switch
- SW1 – RESET

External Interface Headers JP1 and JP2

External interface headers JP1 and JP2 are shown in the schematic on page 15.



Use of Ceramic Resonator Y1

When using ceramic resonator Y1, pins PA0, PA1, and DBG are unavailable to the user. For more information, refer to the *Z8 Encore! XP™ 4K Series Product Specification*, PS0228.

**Z8F04A08100KIT Development Kit
User Manual**

14





Schematic

This section includes schematics for the Z8 Encore! XP 4K Series 8-Pin Development Board.



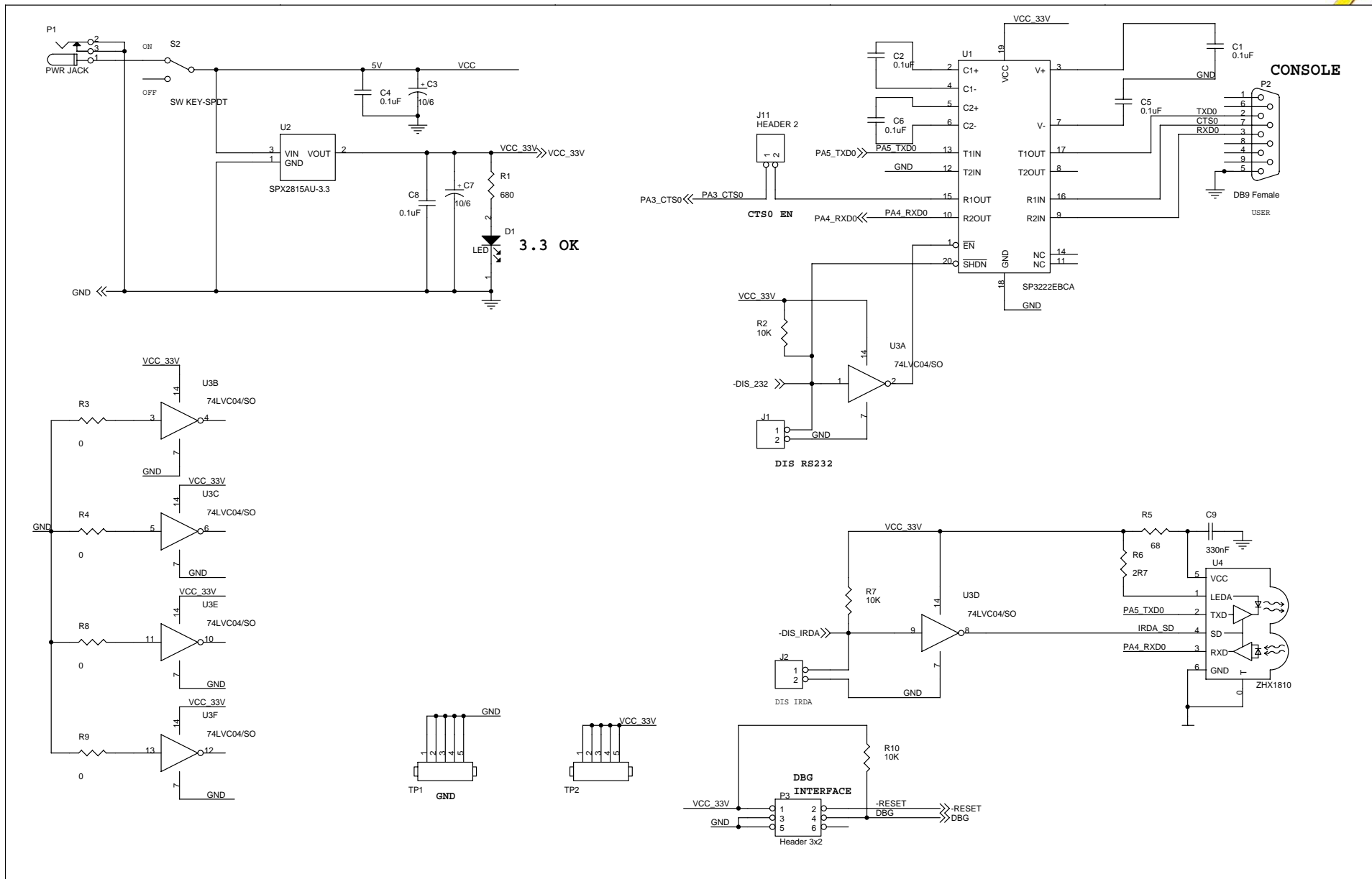

Schematic, Z8 Encore! XPTM 4K Series 8-Pin MCU Development Board, Page 1 of 2

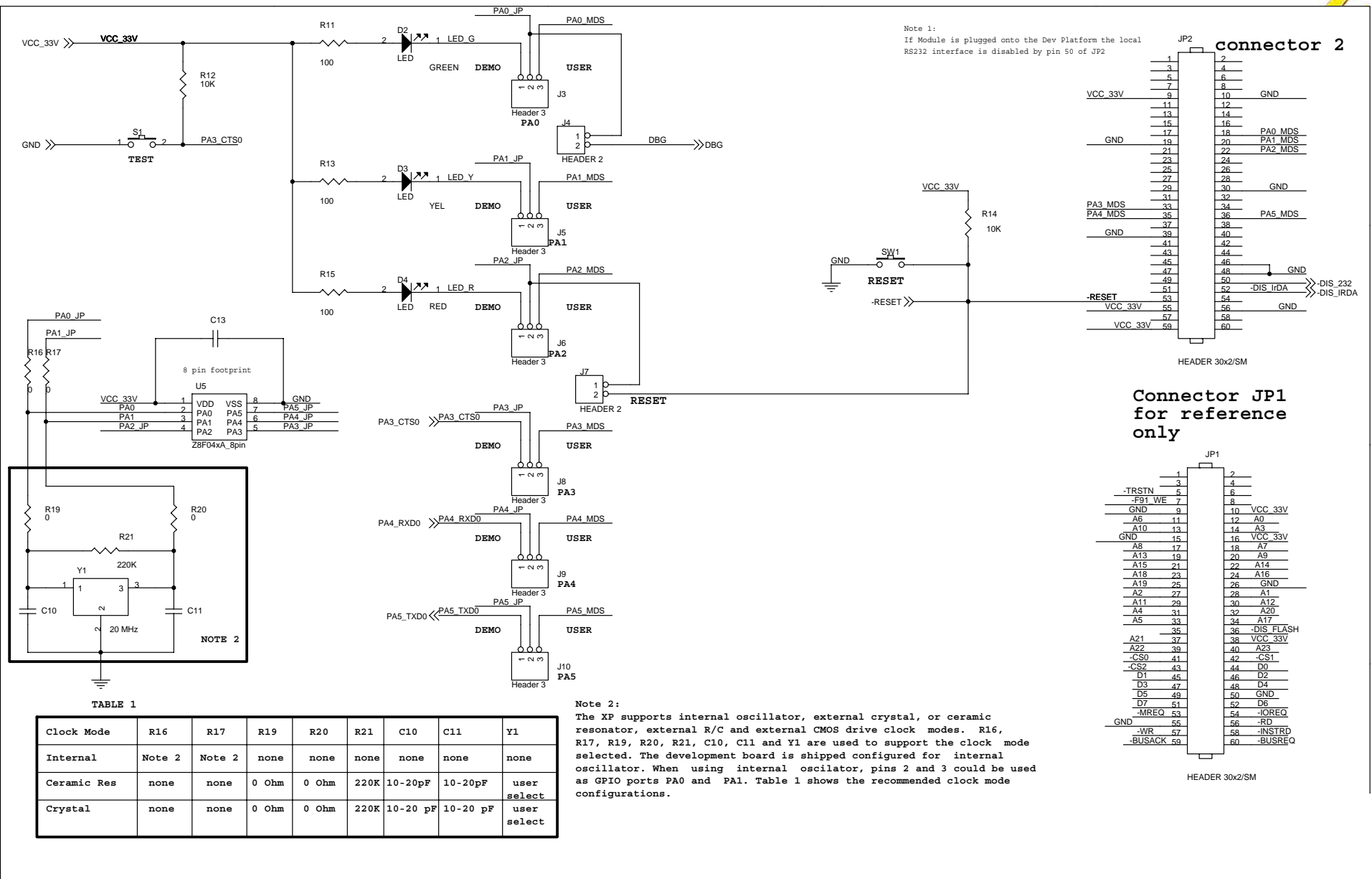

Schematic, Z8 Encore! XP™ 4K Series 8-Pin MCU Development Board, Page 2 of 2