

Auxiliary contacts mounting
Montage des contacts auxiliaires
Montaje de los contactos auxiliares

Maxi : 4 auxiliary contacts
 Maxi : 4 contacts auxiliaires
 Maxi : 4 contactos auxiliares

1 NO (F) : BAC05
 1 NC (O) : BAC06

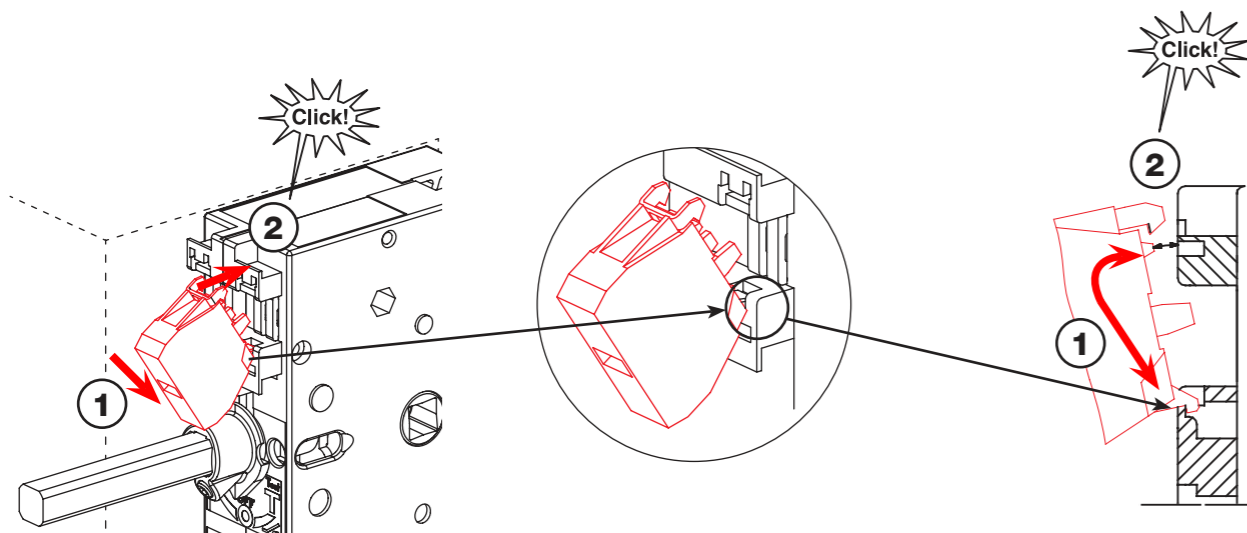
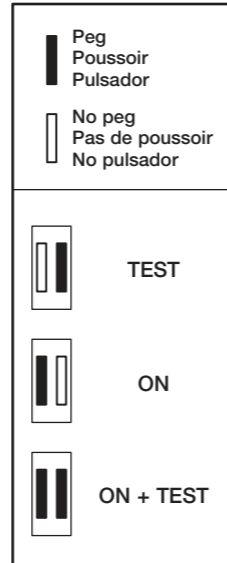

⚠ DANGER / DANGER / PELIGRO

HAZARDOUS VOLTAGE

- This equipment must be installed and serviced only by qualified electrical personnel.
- Turn off all power supplying this equipment before working on or inside equipment.
- Always use a properly rated voltage sensing device to confirm power is OFF.
- Replace all devices, doors, and covers before turning on power to this equipment.
- Maintain electrical clearances between cable and live parts.

Failure to follow these instructions will result in death or serious injury.

TENSION DANGEREUSE

- L'installation et l'entretien de cet appareil ne doivent être effectués que par du personnel qualifié.
- Coupez l'alimentation de cet appareil avant d'y travailler.
- Utilisez toujours un dispositif de détection de tension à valeur nominale approprié pour confirmer que toute alimentation est coupée.
- Remplacez tous les dispositifs, les portes et les couvercles avant de mettre cet appareil sous tension.
- Maintenez les distances d'isolement électrique entre le câble et les pièces sous tension.

Si ces précautions ne sont pas respectées, cela entraînera la mort ou des blessures graves.

TENSION PELIGROSA

- Solamente el personal de mantenimiento eléctrico especializado deberá instalar y prestar servicios de mantenimiento a este equipo.
- Desenergice el equipo antes de realizar cualquier trabajo en él.
- Siempre utilice un dispositivo detector de tensión adecuado para confirmar la desenergización del equipo.
- Vuelva a colocar todos los dispositivos, las puertas y las cubiertas antes de energizar este equipo.
- Mantenga un espacio adecuado para la instalación eléctrica entre el cable y las piezas energizadas.

El incumplimiento de estas precauciones podrá causar la muerte o lesiones serias.

Dual dimensions in/mm
 Double dimensions in/mm
 Doble dimensiones in/mm

- ① RDF30J-2 / RDF60J-2-COMP
- ② RDF30J-3 / RDF60J-3-COMP
- ③ RDF30J-4 / RDF60J-4-COMP
- ④ RDF60J-2 / RDF100J-2
- ⑤ RDF60J-3 / RDF100J-3
- ⑥ RDF60J-4 / RDF100J-4

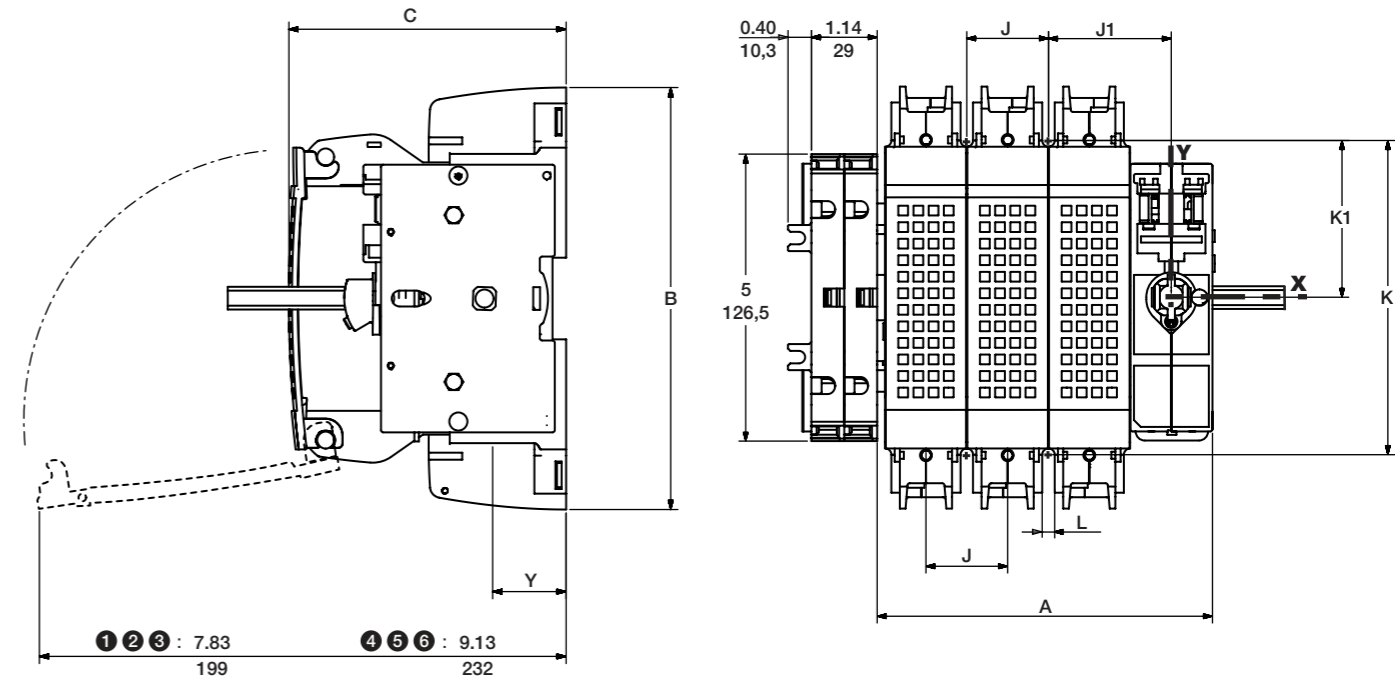

		A		B		C		J		J1		K		K1		L		Y	
		in	mm	in	mm	in	mm	in	mm	in	mm	in	mm	in	mm	in	mm	in	mm
RDF30J-2	2 P	4.27	108,5																
RDF60J-2-COMP																			
RDF30J-3	3 P	5.88	149,5	5.35	136	4.84	123	1.41	36	2.12	54	4.25	108	1.12	54	0.25	6,5	1.43	36,5
RDF60J-3-COMP																			
RDF30J-4	4 P	7.30	185,5																
RDF60J-4-COMP																			
RDF60J-2	2 P	4.27	108,5																
RDF100J-2																			
RDF60J-3	3 P	5.88	149,5	7.32	186	4.84	123	1.41	36	2.12	54	5.45	138,5	2.73	69,5	0.21	5,5	1.16	29,5
RDF100J-3																			
RDF60J-4	4 P	7.30	185,5																
RDF100J-4																			

- ① RDF30J-2 / RDF60J-2-COMP
- ② RDF30J-3 / RDF60J-3-COMP
- ③ RDF30J-4 / RDF60J-4-COMP
- ④ RDF60J-2 / RDF100J-2
- ⑤ RDF60J-3 / RDF100J-3
- ⑥ RDF60J-4 / RDF100J-4

Front operation
Commande frontale
Mando frontal

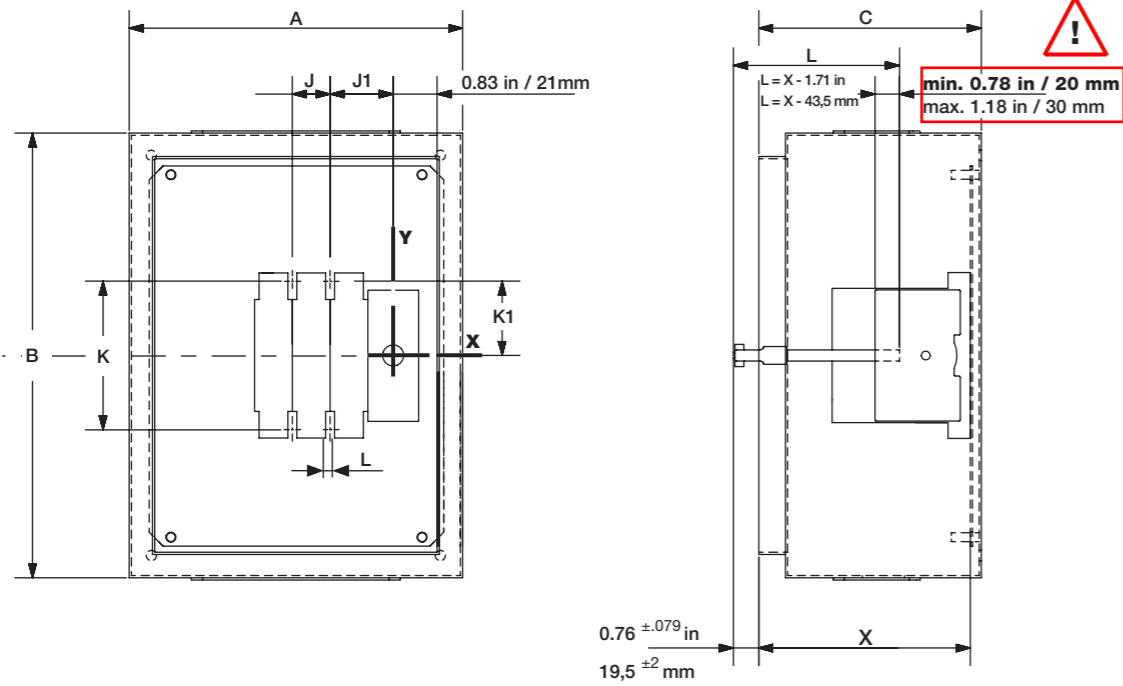

Side operation
Commande latérale
Mando lateral

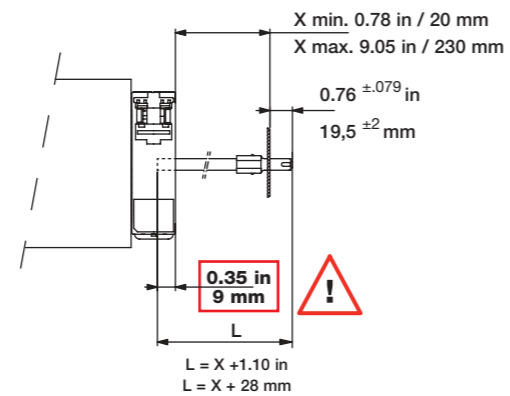

Minimum enclosure dimensions
 Dimensions minimum des coffrets
 Dimensiones mínimas de las cajas

	A		B		C		J		J1		K1		L	
	in	mm	in	mm	in	mm	in	mm	in	mm	in	mm	in	mm
RDF30J-2 RDF60J-2-COMP 2 P	10	254	10	254	6	153	1.41	36	2.12	54	1.12	54	0.25	6,5
RDF30J-3 RDF60J-3-COMP 3 P														
RDF30J-4 RDF60J-4-COMP 4 P														
RDF60J-2 RDF100J-2 2 P	12	305	16	406,5	6	153	1.41	36	2.12	54	2.73	69,5	0.21	5,5
RDF60J-3 RDF100J-3 3 P														
RDF60J-4 RDF100J-4 4 P														

Pozidriv 2 :
 31 lb-in / 3,5Nm

RDF30J-2 RDF60J-2-COMP	2 P	30 - 60A
RDF30J-3 RDF60J-3-COMP	3 P	
RDF30J-4 RDF60J-4-COMP	4 P	

Allen key size 4 :
 6 pans de 4

RDF60J-2 RDF100J-2	2 P	60 - 100A
RDF60J-3 RDF100J-3	3 P	
RDF60J-4 RDF100J-4	4 P	

35.4 lb-in / 4 Nm

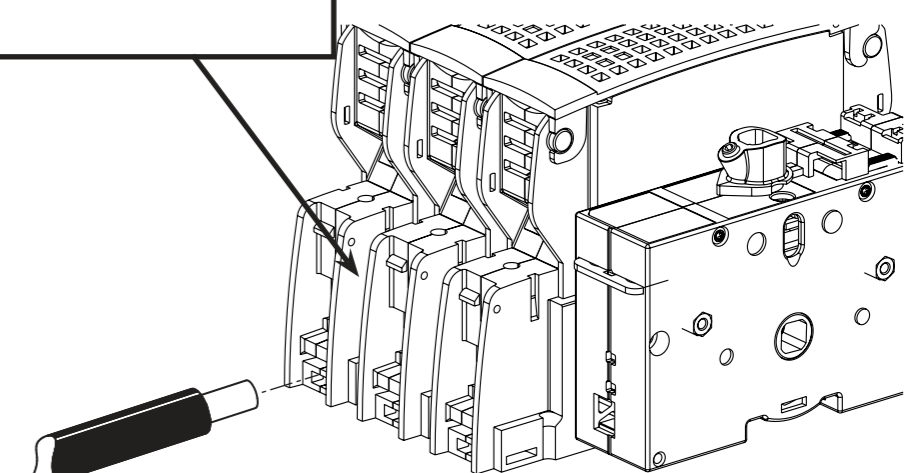

0.47 in 12 mm	RDF30J-2 RDF60J-2-COMP	2 P	30 - 60A
	RDF30J-3 RDF60J-3-COMP	3 P	
	RDF30J-4 RDF60J-4-COMP	4 P	
0.59 in 15 mm	RDF60J-2 RDF100J-2	2 P	60 - 100A
	RDF60J-3 RDF100J-3	3 P	
	RDF60J-4 RDF100J-4	4 P	

Size and torque of cable
 Section et couple de serrage des câbles
 Sección y par de apriete de los cables

	Size / Section Sección (AWG)		Torque Couple Par de apriete	
	min.	max.	lb.in	Nm
RDF30J-2 RDF60J-2-COMP 2 P	Solid Cu		31	3,5
RDF30J-3 RDF60J-3-COMP 3 P	# 14	# 10		
RDF30J-4 RDF60J-4-COMP 4 P	Stranded Cu			
RDF60J-2 RDF100J-2 2 P	Solid Cu		35.4	4
RDF60J-3 RDF100J-3 3 P	# 12	# 10		
RDF60J-4 RDF100J-4 4 P	Stranded Cu			