

NOTES:

1. MATERIAL AND FINISH (PLATING THICKNESS IN MICRO-INCHES):

- BODY; SHELL - BRASS, NICKEL PLATING
- CONTACT PIN - BRASS, GOLD PLATING
- INSULATOR - PTFE, NATURAL
- INSULATOR DISC - ULTEM, NATURAL
- RETAINER RING - SUS 304, NATURAL
- GASKET - SILICONE RUBBER, RED
- FERRULE - COPPER, NICKEL PLATING
- HEAT SHRINK TUBING - POLYOLEFIN, BLACK

2. ELECTRICAL:

- A. IMPEDANCE: 50 OHM
- B. FREQUENCY RANGE: 0-12.4 GHz
- C. VSWR (RETURN LOSS): 1.10 (-26dB) DC-6 GHz
1.20 (-20dB) 6-12.4 GHz
- D. DIELECTRIC WITHSTANDING VOLTAGE: 500 VRMS. MIN.

3. MECHANICAL:

- A. DURABILITY: 500 CYCLES MIN.
- B. TEMPERATURE RANGE: -65°C TO +165°C

4. CABLE ASSEMBLY INSTRUCTIONS:

- A. TRIM CABLE AS SHOWN, TAKING CARE TO NOT DAMAGE THE FOIL.
- B. SLIDE INSULATOR DISC, FERRULE AND HEAT SHRINK TUBE ONTO CABLE
- C. SOLDER CONTACT TO CABLE CENTER CONDUCTOR
- D. INSERT CABLE AND CONTACT INTO CONNECTOR. FOIL IS A SLIP FIT INTO Ø1.75 BODY DIAMETER
- E. CRIMP FERRULE WITH .128" HEX

6. PACKING:

- A. QUANTITY: SINGLE PACK
- B. MARKING: BAG TO BE MARKED "AMPHENOL RF, 901-10604, DATE CODE"

THIRD ANGLE PROJ.

REVISIONS

REV	DESCRIPTION	DATE	ECO	APPR
A	RELEASE TO MANUFACTURING	07-May-19	11442	CJV

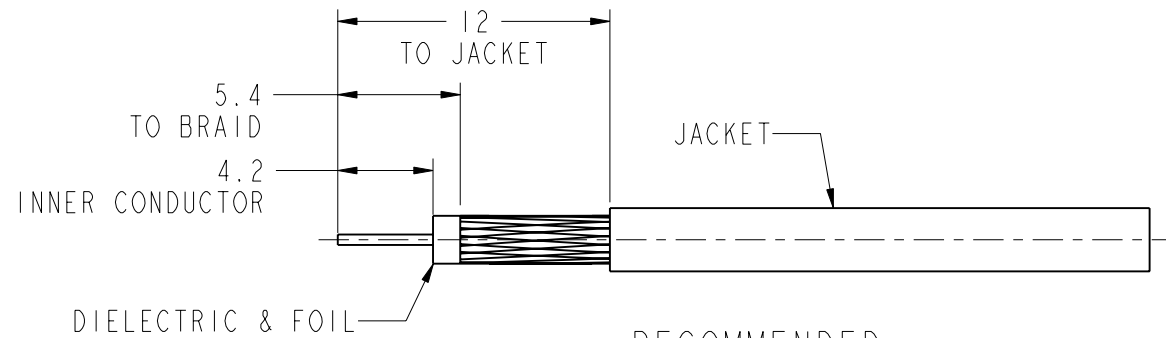

RECOMMENDED
CABLE STRIPPING DIM'S

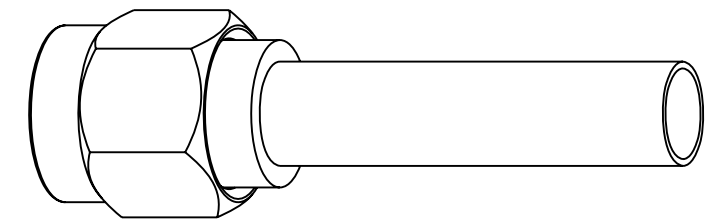

SCALE 3.000

5. CABLE ENTRY DIMENSIONS

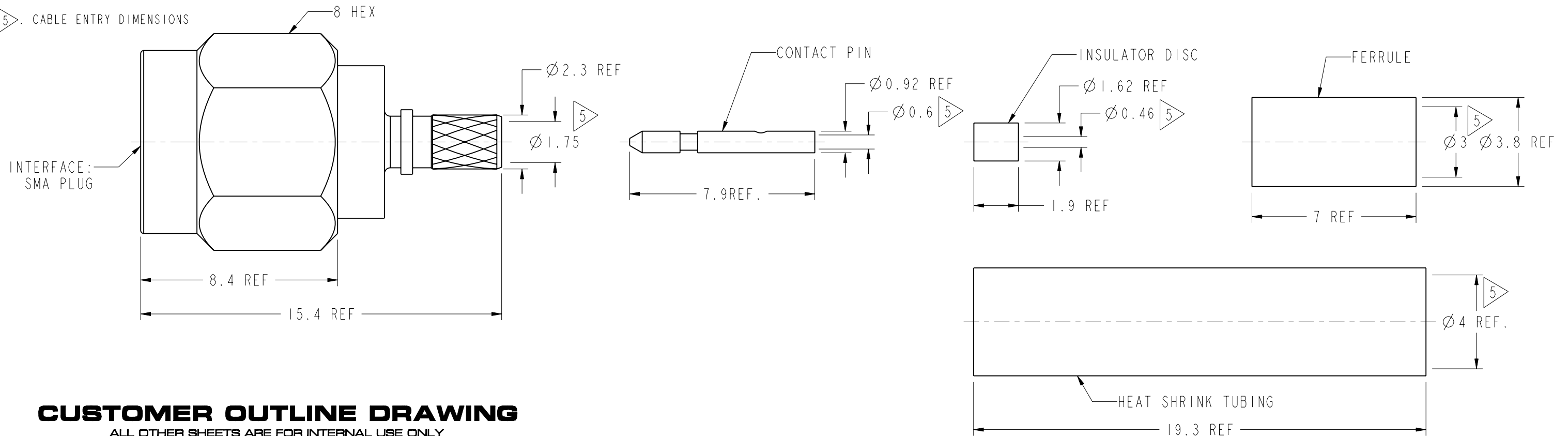

CUSTOMER OUTLINE DRAWING

ALL OTHER SHEETS ARE FOR INTERNAL USE ONLY

UNLESS OTHERWISE SPECIFIED, DIMENSIONS ARE IN METRIC AND TOLERANCES ARE:				
<0.5mm	0.5 - 6mm	6 - 30mm	30 - 120mm	ANGLES
± 0.05mm	± 0.1mm	± 0.2mm	± 0.3mm	± 1°

NOTICE - These drawings, specifications, or other data (1) are, and remain the property of Amphenol corp. (2) must be returned upon request; and (3) are confidential and not to be disclosed to any person other than those to whom they are given by Amphenol Corp. the furnishing of these drawings, specifications, or other data by Amphenol Corp., or to any other person to anyone for any purpose is not to be regarded by implication or otherwise in any manner licensing, granting rights to permitting such holder or any other person to manufacture, use or sell any product, process or design, patented or otherwise, that may in any way be related to or disclosed by said drawings, specifications, or other data.

MATERIAL SEE NOTES	DRAWN W.ZENG	DATE 8-May-19
REFERENCE EAR 7994	ENGINEER S.DUAN	DATE 17-May-19
CONFIGURATION LEVEL:	APPROVED S.HSIEH	DATE 20-May-19
FINISH	CAD FILE	

TITLE SMA CRIMP PLUG FOR LMR-100A CABLE
SCALE: 6.0:1.0 SHEET 2 OF 2
DWG SIZE B REV A

Amphenol RF www.amphenolrf.com	
DRAWING NO.	901-10604
ITEM NO.	901-10604
PART NO.	901-10604