

## 0.45 Ω, Low Voltage Dual SPDT Analog Switch with Negative Swing Audio Capability

### DESCRIPTION

The DG2750 is a dual SPDT low on-resistance switch designed to from a single 1.6 V to 5.5 V power supply. It is a bi-directional switch, and is capable of switching negative swing audio without the need for a coupling capacitor. With a single power supply, the audio signal can swing over the range from  $(V+ - 5)$  to  $V+$ .

Guaranteed to operate with 1.4 V logic when  $V+$  is in the range of 2.7 V to 5.5 V, the DG2750 will allow an easy interface with low voltage DSP or ASIC control logic.

The DG2750 is built on sub micron CMOS low voltage process technology, has very low quiescent current, and provides greater than 600 mA latch-up protection, as tested per JESD78.

The DG2750 is assembled in compact mQFN10, 1.4 mm x 1.8 mm x 0.55 mm and ultra thin UTMQFN of 0.35 mm thickness.

As a committed partner to the community and the environment, Vishay Siliconix manufactures this product with lead (Pb)-free device termination. The miniQFN-10 package has a nickel-palladium-gold device termination and is represented by the lead (Pb)-free “-E4” suffix to the ordering part number. The nickel-palladium-gold device terminations meet all JEDEC® standards for reflow and MSL rating.

As a further sign of Vishay Siliconix’s commitment, the DG2750 is fully RoHS-complaint and halogen-free.

### FEATURES

- 1.6 V to 5.5 V single power rail operation
- Capable to switch negative swing audio without DC blocking capacitor
- Low signal distortion: THD+N < -98 dB
- Low on-resistance
- 1.4 V high logic
- Latch-up current > 600 mA (JESD78)
- ESD (HBM): 8 kV
- Reduced power consumption
- Reduce board space
- Material categorization: for definitions of compliance please see [www.vishay.com/doc?99912](http://www.vishay.com/doc?99912)



### APPLICATIONS

- Cellular phones
- Portable media players
- Computer and game machine
- Handheld healthcare and instruments

### FUNCTIONAL BLOCK DIAGRAM AND PIN CONFIGURATION

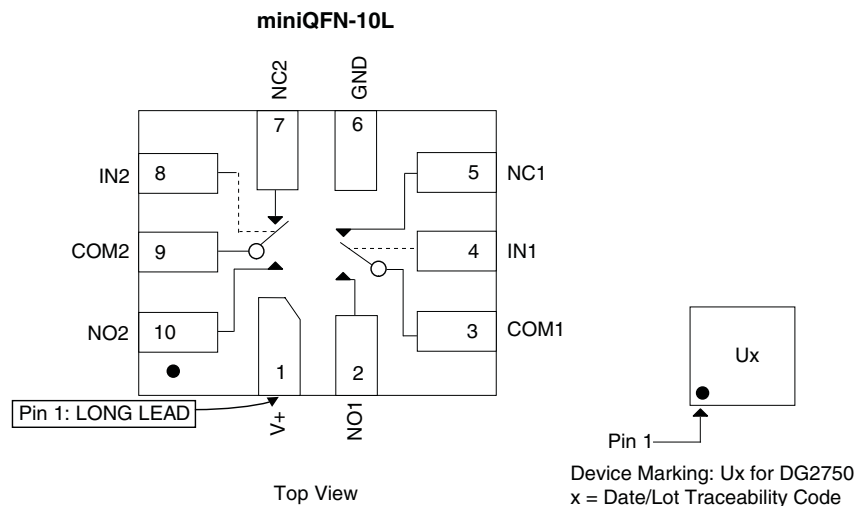



ORDERING INFORMATION			
PART NUMBER	TEMPERATURE RANGE	PACKAGE	SIZE
DG2750DN-T1-E4	-40 °C to +85 °C	miniQFN-10	1.4 mm x 1.8 mm x 0.55 mm
DG2750DN1-T1-GE4		UTMQFN-10	1.4 mm x 1.8 mm x 0.35 mm

TRUTH TABLE, DG2750		
IN1 (PIN 4)	IN2 (PIN 8)	FUNCTION
0	X	COM1 = NC1
1	X	COM1 = NO1
X	0	COM2 = NC2
X	1	COM2 = NO2

ABSOLUTE MAXIMUM RATINGS (T <sub>A</sub> = 25 °C, unless otherwise noted)			
PARAMETER		LIMIT	UNIT
Reference to GND	V+, IN	-0.3 to +6	V
	COM, NO, NC <sup>a</sup>	(V+) -5.5 or -2.5 whichever higher, (V+ + 0.3)	
Current (Any Terminal except COM, NO, NC, IN)		30	mA
Continuous Current (COM, NO, NC, IN)		± 250	
Peak Current (Pulsed at 1 ms, 10 % Duty Cycle)		± 500	
Storage Temperature (D Suffix)		-65 to +150	°C
Power Dissipation (Packages) <sup>b</sup>	miniQFN-10 <sup>c</sup>	208	mW
ESD (Human Body Model) I/O to GND		8	kV
Latch-up (per JEDEC78)		600	mA

**Notes**

- a. Signals on COM, NO, NC, exceeding V+ will be clamped by internal diodes. Limit forward diode current to maximum current ratings
- b. All leads welded or soldered to PC board
- c. Derate 2.6 mW/°C above 70 °C

SPECIFICATIONS (V <sub>+</sub> = 2.7 V, ± 10 %)							
PARAMETER	SYMBOL	TEST CONDITIONS OTHERWISE UNLESS SPECIFIED	TEMP. <sup>a</sup>	LIMITS -40 °C to +85 °C			UNIT
				MIN. <sup>b</sup>	TYP. <sup>c</sup>	MAX. <sup>b</sup>	
<b>Analog Switch</b>							
Analog Signal Range <sup>d</sup>	V <sub>ANALOG</sub>		Full	-2.5	-	V+	V
On-Resistance	R <sub>DS(on)</sub>	V <sub>+</sub> = 2.7 V, V <sub>S</sub> = (V+) -4.5 V, -1 V, 0 V, 1 V, 2 V, V+), I <sub>S</sub> = 100 mA	Room	-	0.45	1	Ω
On-Resistance Match	ΔR <sub>ON</sub>		Full	-	-	1.3	
On-Resistance Flatness	R <sub>ON</sub> Flatness		Room	-	0.1	-	
			Room	-	0.3	-	
Switch Off Leakage Current	I <sub>NO/NC(off)</sub>	V <sub>+</sub> = 2.7 V, V <sub>NC/NO</sub> = -2.5 V or 2.5 V, V <sub>COM</sub> = 2.5 V or -2.5 V	Room	-	50	-	nA
	I <sub>COM(off)</sub>		Full	-250	-	250	
Channel On Leakage Current	I <sub>COM(on)</sub>		Room	-	50	-	
			Full	-250	-	250	
<b>Digital Control</b>							
Input Voltage High	V <sub>INH</sub>	V <sub>+</sub> = 2.7 V to 4.3 V	Full	1.4	-	-	V
Input Voltage Low	V <sub>INL</sub>		Full	-	-	0.6	
Input Capacitance	C <sub>IN</sub>		Room	-	6.5	-	pF
Input Current	I <sub>INL</sub> or I <sub>INH</sub>	V <sub>IN</sub> = 0 or V+	Full	-1	-	1	μA

SPECIFICATIONS ( $V_+ = 2.7\text{ V}, \pm 10\%$ )							
PARAMETER	SYMBOL	TEST CONDITIONS OTHERWISE UNLESS SPECIFIED	TEMP. <sup>a</sup>	LIMITS -40 °C to +85 °C			UNIT
				MIN. <sup>b</sup>	TYP. <sup>c</sup>	MAX. <sup>b</sup>	
<b>Dynamic Characteristics</b>							
Break-Before-Make Time <sup>e, d</sup>	$t_{\text{BBM}}$	$V_+ = 3\text{ V}, V_S = 1.5\text{ V}, R_L = 50\ \Omega,$ $C_L = 35\text{ pF}$	Room	800	1160	-	ns
			Full	1000	-	-	
Enable Turn-On Time <sup>e, d</sup>	$t_{\text{ON(EN)}}$		Room	-	1200	2100	
			Full	-	-	2500	
Enable Turn-Off Time <sup>e, d</sup>	$t_{\text{OFF(EN)}}$		Room	-	33	130	
			Full	-	-	150	
Charge Injection <sup>d</sup>	$Q_{\text{INJ}}$	$C_L = 1\text{ nF}, R_{\text{GEN}} = 0\ \Omega, V_{\text{GEN}} = 0\text{ V}$	Room	-	4	-	pC
Total Harmonic Distortion Plus Noise <sup>d</sup>	THD+N	$f = 20\text{ Hz to } 20\text{ kHz}, V_{\text{COM}} = 0.5\text{ V}_{\text{P-P}},$ $R_S = R_L = 600\ \Omega; \text{DC bias} = 0\text{ V}$		-	< -98	-	dB
Off-Isolation <sup>d</sup>	OIRR	$V_+ = 3\text{ V}, R_L = 50\ \Omega, C_L = 5\text{ pF},$ $f = 300\text{ kHz}$		-	-54	-	dB
Crosstalk <sup>d, f</sup>	$X_{\text{TALK}}$	$f = 300\text{ kHz}$		-	-60	-	dB
Bandwidth <sup>d</sup>	BW	$V_+ = 3\text{ V}, R_L = 50\ \Omega, -3\text{ dB}$		-	49	-	MHz
Channel-Off Capacitance <sup>d</sup>	$C_{\text{NC/NO(off)}}$	$V_+ = 3\text{ V}, f = 1\text{ MHz}$		-	36	-	pF
Channel-On Capacitance <sup>d</sup>	$C_{\text{COM/NC/NO(on)}}$			-	106	-	
<b>Power Supply</b>							
Power Supply Range	$V_+$			1.6	-	5.5	V
Power Supply Current	$I_+$	$V_{\text{IN}} = 0\text{ V}, \text{ or } V_+$	Full	-	-	2	$\mu\text{A}$

**Notes**

- Room = 25 °C, Full = as determined by the operating suffix
- The algebraic convention whereby the most negative value is a minimum and the most positive a maximum, is used in this data sheet
- Typical values are for design aid only, not guaranteed nor subject to production testing
- Guarantee by design, not subjected to production test
- $V_{\text{IN}} = V_+$  voltage to perform proper function
- Crosstalk measured between channels

Stresses beyond those listed under "Absolute Maximum Ratings" may cause permanent damage to the device. These are stress ratings only, and functional operation of the device at these or any other conditions beyond those indicated in the operational sections of the specifications is not implied. Exposure to absolute maximum rating conditions for extended periods may affect device reliability.

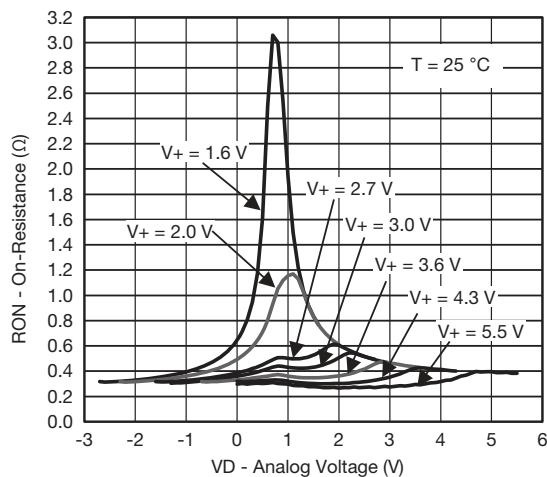
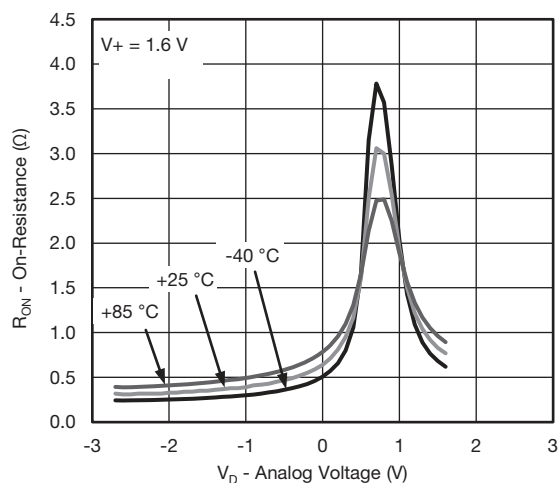
**TYPICAL CHARACTERISTICS (25 °C, unless otherwise noted)**

**On-Resistance vs.  $V_D$  and Single Supply Voltage**

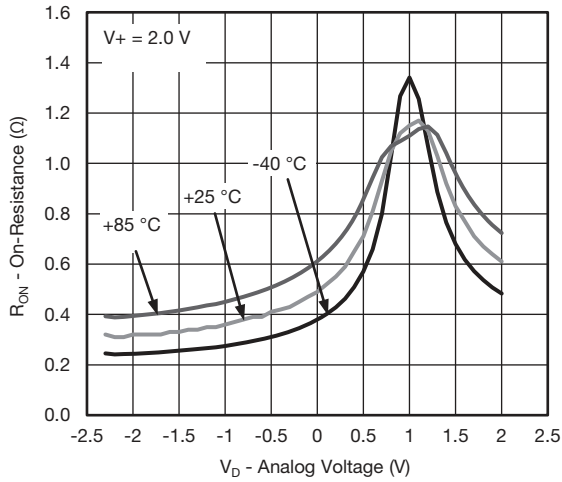
**On-Resistance vs. Analog Voltage and Temperature**

**TYPICAL CHARACTERISTICS** (25 °C, unless otherwise noted)

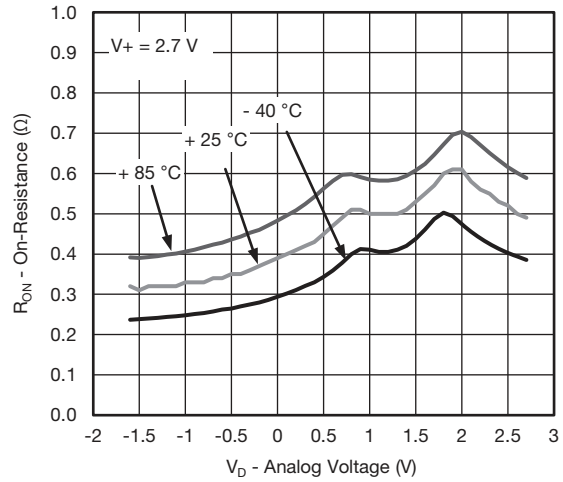

**On-Resistance vs. Analog Voltage and Temperature**



**On-Resistance vs. Analog Voltage and Temperature**

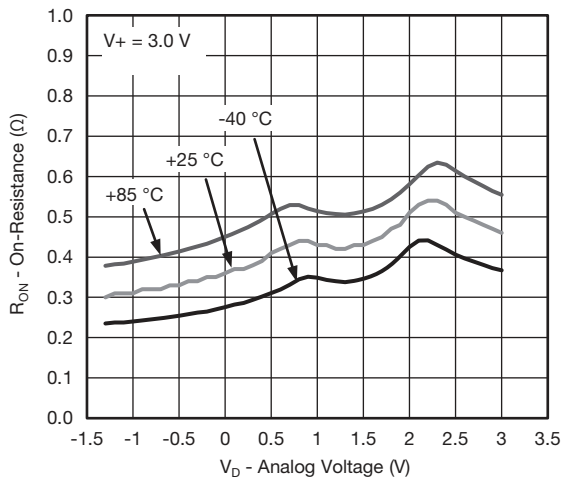

**On-Resistance vs. Analog Voltage and Temperature**

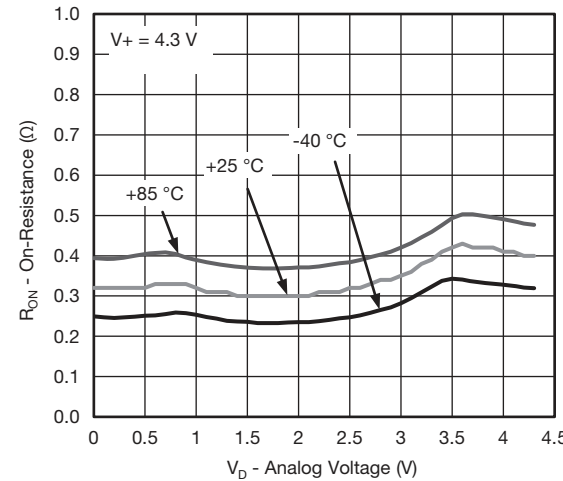

**On-Resistance vs. Analog Voltage and Temperature**

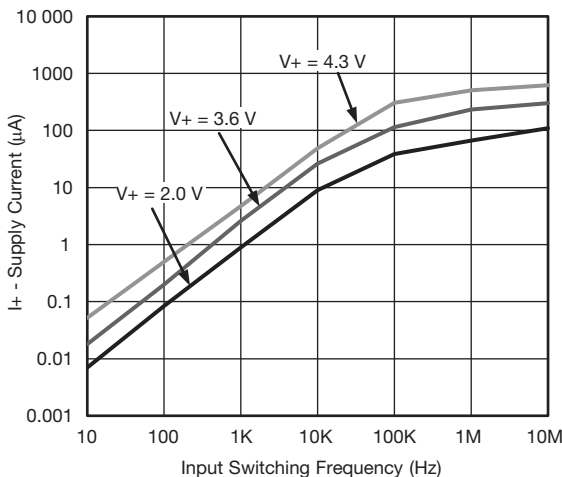

**Supply Current vs. Input Switching Frequency**

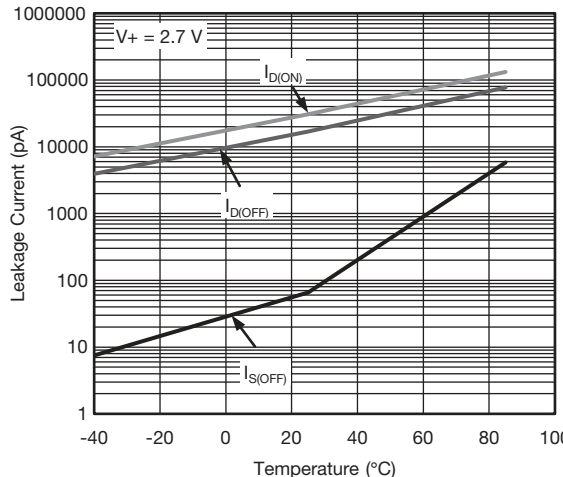

**Leakage Current vs. Temperature**

**TYPICAL CHARACTERISTICS** (25 °C, unless otherwise noted)

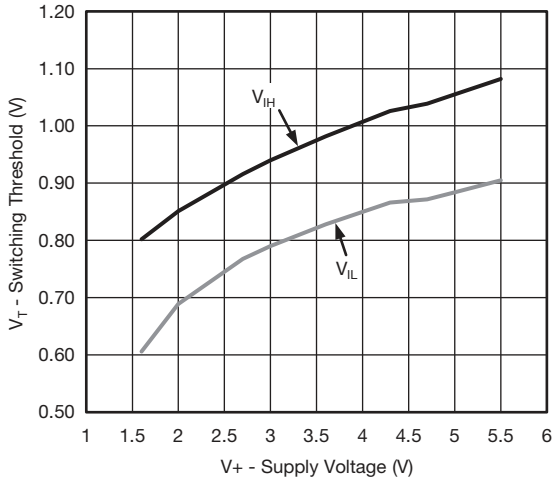

Switching Threshold vs. Supply Voltage

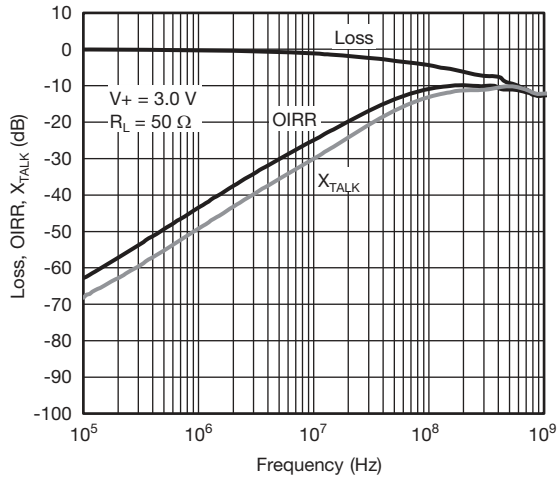

Insertion Loss, Off-Isolation, Crosstalk vs. Frequency

**TEST CIRCUITS**

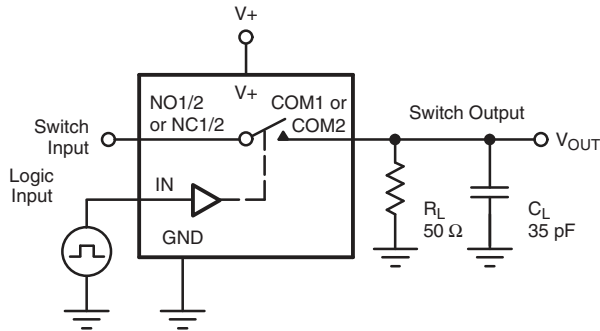

$C_L$  (includes fixture and stray capacitance)

$$V_{OUT} = V_{COM} \left( \frac{R_L}{R_L + R_{ON}} \right)$$

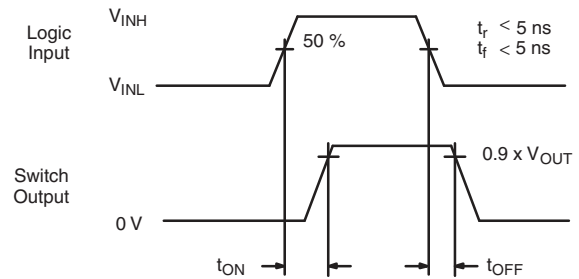

Logic "1" = Switch on  
Logic input waveforms inverted for switches that have the opposite logic sense.

Fig. 1 - Switching Time

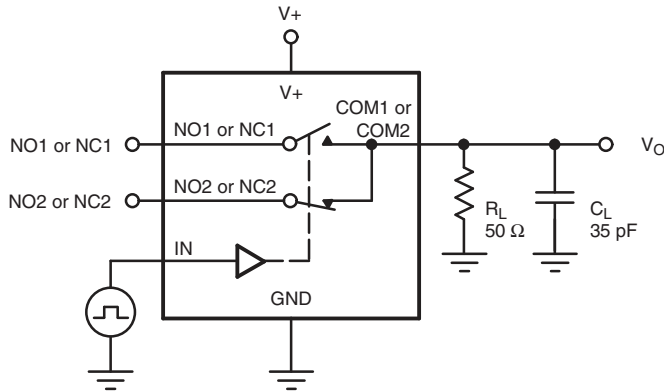

$C_L$  (includes fixture and stray capacitance)

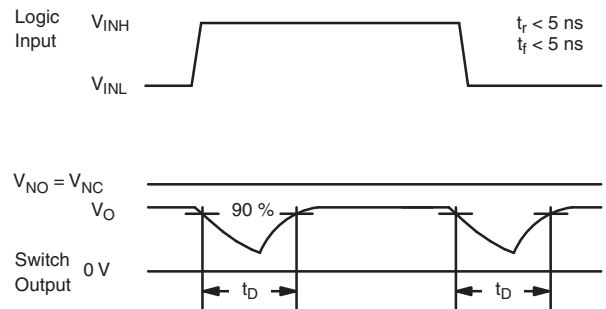
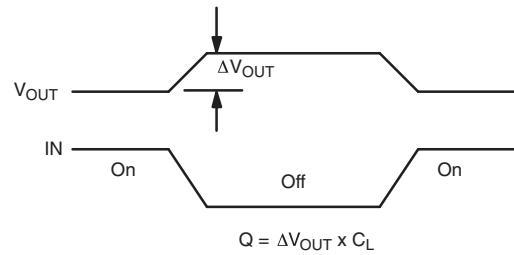
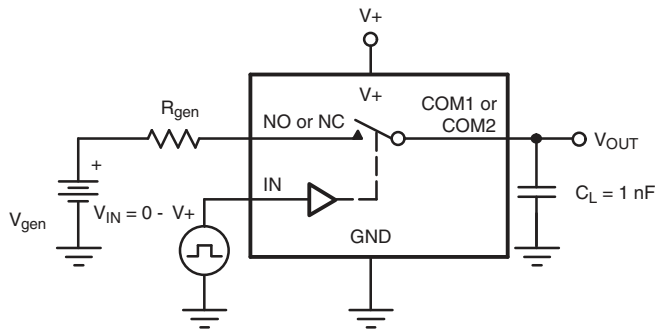

Fig. 2 - Break-Before-Make Interval

TEST CIRCUITS



IN depends on switch configuration: input polarity determined by sense of switch.

Fig. 3 - Charge Injection

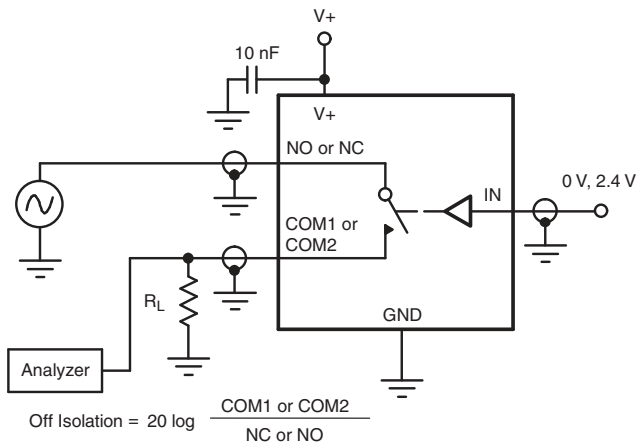

$$\text{Off Isolation} = 20 \log \frac{\text{COM1 or COM2}}{\text{NC or NO}}$$

Fig. 4 - Off-Isolation

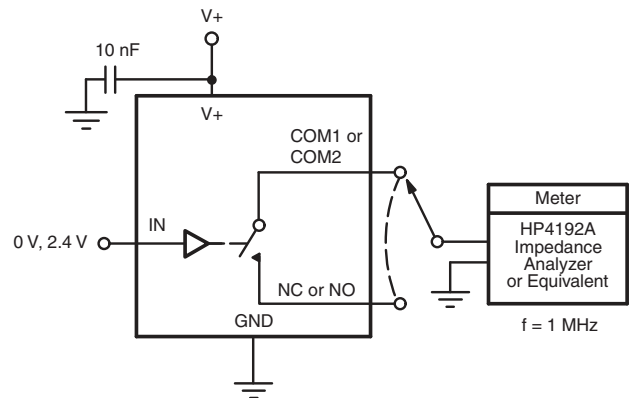
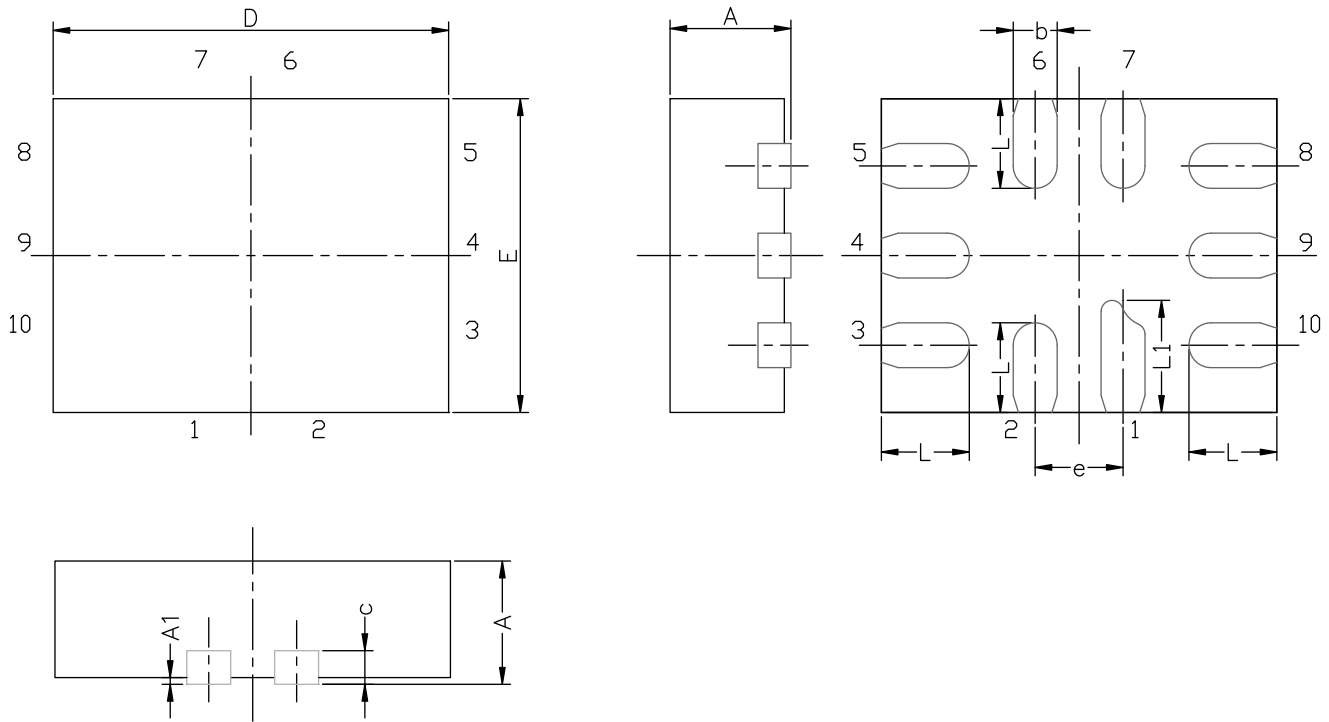

Fig. 5 - Channel Off/On Capacitance

Vishay Siliconix maintains worldwide manufacturing capability. Products may be manufactured at one of several qualified locations. Reliability data for Silicon Technology and Package Reliability represent a composite of all qualified locations. For related documents such as package/tape drawings, part marking, and reliability data, see [www.vishay.com/ppg?64736](http://www.vishay.com/ppg?64736).

**MINI QFN-10L CASE OUTLINE**

DIM	MILLIMETERS			INCHES		
	MIN.	NAM.	MAX.	MIN.	NAM.	MAX.
A	0.45	0.55	0.60	0.0177	0.0217	0.0236
A1	0.00	-	0.05	0.000	-	0.002
b	0.15	0.20	0.25	0.006	0.008	0.010
c	0.150 or 0.127 REF <sup>(1)</sup>			0.006 or 0.005 REF <sup>(1)</sup>		
D	1.70	1.80	1.90	0.067	0.071	0.075
E	1.30	1.40	1.50	0.051	0.055	0.059
e	0.40 BSC			0.016 BSC		
L	0.35	0.40	0.45	0.014	0.016	0.018
L1	0.45	0.50	0.55	0.0177	0.0197	0.0217

**Note**

<sup>(1)</sup> The dimension depends on the leadframe that assembly house used.

ECN T16-0163-Rev. B, 16-May-16  
DWG: 5957

**RECOMMENDED MINIMUM PADS FOR MINI QFN 10L**

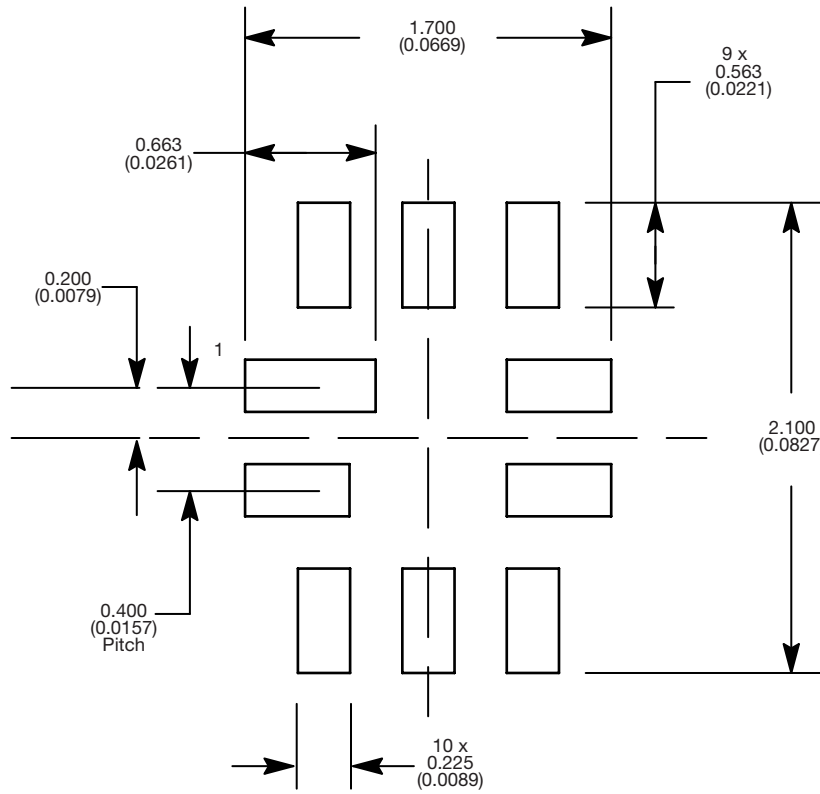

Mounting Footprint  
Dimensions in mm (inch)





## Disclaimer

ALL PRODUCT, PRODUCT SPECIFICATIONS AND DATA ARE SUBJECT TO CHANGE WITHOUT NOTICE TO IMPROVE RELIABILITY, FUNCTION OR DESIGN OR OTHERWISE.

Vishay Intertechnology, Inc., its affiliates, agents, and employees, and all persons acting on its or their behalf (collectively, "Vishay"), disclaim any and all liability for any errors, inaccuracies or incompleteness contained in any datasheet or in any other disclosure relating to any product.

Vishay makes no warranty, representation or guarantee regarding the suitability of the products for any particular purpose or the continuing production of any product. To the maximum extent permitted by applicable law, Vishay disclaims (i) any and all liability arising out of the application or use of any product, (ii) any and all liability, including without limitation special, consequential or incidental damages, and (iii) any and all implied warranties, including warranties of fitness for particular purpose, non-infringement and merchantability.

Statements regarding the suitability of products for certain types of applications are based on Vishay's knowledge of typical requirements that are often placed on Vishay products in generic applications. Such statements are not binding statements about the suitability of products for a particular application. It is the customer's responsibility to validate that a particular product with the properties described in the product specification is suitable for use in a particular application. Parameters provided in datasheets and / or specifications may vary in different applications and performance may vary over time. All operating parameters, including typical parameters, must be validated for each customer application by the customer's technical experts. Product specifications do not expand or otherwise modify Vishay's terms and conditions of purchase, including but not limited to the warranty expressed therein.

Except as expressly indicated in writing, Vishay products are not designed for use in medical, life-saving, or life-sustaining applications or for any other application in which the failure of the Vishay product could result in personal injury or death. Customers using or selling Vishay products not expressly indicated for use in such applications do so at their own risk. Please contact authorized Vishay personnel to obtain written terms and conditions regarding products designed for such applications.

No license, express or implied, by estoppel or otherwise, to any intellectual property rights is granted by this document or by any conduct of Vishay. Product names and markings noted herein may be trademarks of their respective owners.