

LAST TIME BUY

Closest Alternative Part AP5727WUG-7

ZXLB1600

LCD AND OLED BIAS BOOST CONVERTER - STN, CSTN SCREENS

DESCRIPTION

The ZXLB1600 inductive switching boost converter accepts an input voltage of between 1.6V and 5.5V and provides an adjustable output voltage of up to 28V for LCD and OLED bias. The device contains an output switch and a second switch to isolate the coil from the input to provide true isolation in shutdown mode. The output can be adjusted by means of an externally applied dc voltage, a PWM control signal, or external feedback resistors and can supply typically 10mA of output current at maximum output voltage. Higher current is available at lower output voltages.

The input voltage range accepts a number of battery solutions, including dual dry cell and single Li-Ion cells and PFM operation mode allows the output to be regulated with high efficiency under light or no load conditions. The switching frequency range permits the use of miniature surface mount inductors.

A low battery comparator is provided to indicate when the input voltage has fallen to within $\pm 2\%$ of a preset threshold. This threshold is set internally, but can be adjusted externally to any voltage within the supply voltage range.

FEATURES

- Wide input voltage range: 1.6 to 5.5V
- Adjustable output voltage up to 28V, using PWM or analog control voltage
- Internal PWM filter
- True shutdown (output isolated from input)
- Internal output switch and current sense
- Low quiescent current: (75 μ A max)
- 5 μ A (max) shutdown current (including low battery comparator)
- Up to 500kHz switching frequency
- High efficiency
- Small MSOP10 package
- Low external component count

APPLICATIONS

- PDAs
- Mobile phones - OLED sub displays
- Digital cameras
- Portable internet appliances
- Palmtop computers
- GPS terminals

TYPICAL APPLICATION CIRCUIT

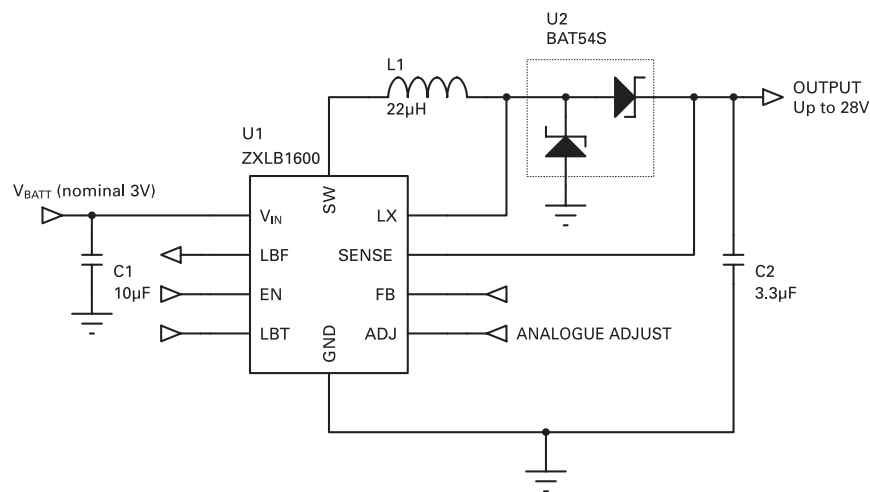

LAST TIME BUY

Closest Alternative Part AP5727WUG-7

ZXLB1600

ABSOLUTE MAXIMUM RATINGS

(Voltages to GND unless otherwise stated)

Output voltage	30V
Input voltage	7V
Switch output current	500mA
Power dissipation	800mW
Operating temperature	0 to 70°C
Storage temperature	-55 to 125°C
Junction temperature	150°C

ELECTRICAL CHARACTERISTICS

Test conditions unless otherwise stated: $V_{IN} = 3.0V$, $T_{AMB} = 25^{\circ}C$

Symbol	Parameter	Conditions	Min	Typ	Max	Units
General						
V_{IN}	Input voltage ⁽¹⁾		1.6		5.5	V
I_{IN}	Supply current Shutdown ⁽²⁾	$V_{EN} = 0V$		3.5	5	μA
	Quiescent	$V_{EN} = V_{IN}$, $I_{OUT} = 0V$, Not switching		30	75	μA
Isolating switch						
R_{ISO}	'On' resistance	$V_{EN} = V_{IN}$		0.7	2	Ω
I_{ISO}	Leakage current	$V_{EN} = 0V$			1	μA
$V_{SW(max)}$	Maximum voltage on SW pin during normal operation				$V_{IN}+0.5$	V
LX Switch						
I_{LX}	Switch peak current limit ⁽³⁾		0.15		0.35	A
R_{LX}	'On' resistance			0.5	2	Ω
$I_{LX(leak)}$	Switch leakage current				1	μA
V_{LX}	Operating voltage on LX pin		-0.5		30	V
Controller output						
V_{OUT}	Output voltage range		V_{IN}		28	V
I_{OUT}	Output current	$Lx = 22\mu H$, $V_{OUT} = 28V$	5	10		mA
ΔV_{LNR}	Line regulation	$I_{OUT} = 1mA$, $2V < V_{IN} < 5.5V$		0.1		%/V
ΔV_{LDR}	Load regulation	$V_{OUT} = 28V$, $100\mu A < I_{OUT} < 5mA$		0.15		%/mA
f_{LX}	Operating frequency				500	kHz
T_{ON}	Output 'ON' time	LX output low			10	μs
T_{OFF}	Output 'OFF' time	LX output off	0.9			μs
η	Efficiency ⁽⁴⁾	$Lx = 22\mu H$, $V_{OUT} = 20V$		80		%

Note:

- 1) Minimum supply voltage should be maintained above 2V for operation at minimum temperature.
- 2) Shutdown current includes the operating current for the low battery comparator, which remains active in shutdown mode.
- 3) This is the dc value. The dynamic value may exceed 350mA during normal operation, due to switching delays, coil inductance and supply voltage.
- 4) Efficiency is dependent upon the choice of external components, input/output voltages and load current.(see typical operating curves).

LAST TIME BUY

Closest Alternative Part AP5727WUG-7

ZXLB1600

ELECTRICAL CHARACTERISTICS (Cont.)

Test conditions unless otherwise stated: $V_{IN} = 3.0V$, $T_{AMB} = 25^{\circ}C$

Symbol	Parameter	Conditions	Min	Typ	Max	Units
Output voltage control by dc voltage applied to 'ADJ' pin						
$V_{ADJ (nom)}$	Internal reference voltage	'ADJ' pin floating, 'EN' = V_{IN}		1.23		V
	Temperature coefficient of V_{ADJ}			40		ppm/ $^{\circ}C$
V_{ADJ}	External overdrive voltage range on 'ADJ' pin for output voltage control		0.5		$V_{ADJ (NOM)}$	V
I_{ADJ}	Input current into V_{ADJ} pin	$0.5 < V_{ADJ} < V_{ADJ (NOM)}$			-10	μA
V_{SENSE}	Default Output voltage	'ADJ' pin floating, 'EN' = V_{IN}	27		29	V
Output voltage control by PWM signal applied to 'EN' input						
$\Delta T/T$	PWM duty cycle range at 'EN' input	$10kHz^{(5)} < f < 100kHz$, $V_{ENH} = V_{IN}$	40		100	%
f_{LPPF}	Internal low pass filter cut-off frequency			4		kHz
A_{LPPF}	Filter attenuation	$f = 30kHz$		52.5		dB
Internal voltage setting resistors for output voltage						
R1	Ref. Block diagram			317		k Ω
R2				6.93		M Ω
Enable input						
V_{ENL}	Low level Input voltage	Device in shutdown			0.4	V
V_{ENH}	High level Input voltage	Device active	1.4		V_{in}	V
I_{ENL}	Low level input current	$V_{EN} = 0V$			-100	nA
I_{ENH}	High level input current	$V_{EN} = V_{IN}$			100	nA
$T_{EN(hold)}$	Enable active hold time ⁽⁶⁾	V_{EN} switched from high to low		120		μs
Low-battery detection circuit						
V_{LBT}	Detection threshold	V_{IN} falling	1.94		2.02	V
	Temperature coefficient of V_{LBT}			20		ppm/ $^{\circ}C$
V_{BLHYS}	Hysteresis	V_{IN} rising		20		mV
Ref _(LBD)	Internal reference voltage			1.21		V
$V_{LBT (max)}$	Maximum voltage on LBT pin				$V_{in} - 0.5$	V
I_{BLOL}	Low level output current	Output 'on'			1	mA
V_{BLOL}	Low level output voltage	$I_{BLOL} = 0.5mA$			0.4	V
I_{BLOH}	High level output current	Output 'off', $V_{BLOH} = 29V$			2	μA
V_{BLOH}	High level output voltage	Output 'off'			29	V
Internal voltage setting resistors for low-battery detection circuit						
R3	Ref. block diagram			1.56		M Ω
R4				2.44		M Ω

Note:

- 5) This is the minimum PWM frequency to maintain a continuous output. Lower frequencies can be used, but will result in gated operation of the device i.e. device enters shutdown when EN is low (see Note 6).
- 6) This is the time for which the device remains active after the EN pin has been driven low. This delay allows a continuous output to be maintained during PWM mode operation at frequencies higher than 10kHz.

LAST TIME BUY

Closest Alternative Part AP5727WUG-7

ZXLB1600

PIN CONNECTIONS

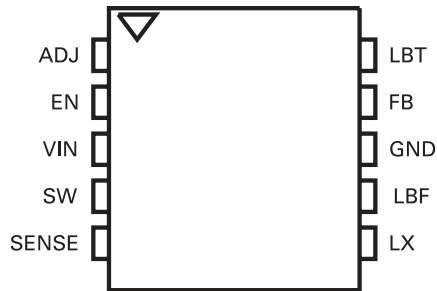

PIN DESCRIPTION

Pin #	Name	Description
1	ADJ	Internal (or external) reference voltage. Can be overdriven to adjust output voltage
2	EN	Enable input (active high) Also used to adjust output voltage by PWM signal
3	VIN	Input voltage
4	SW	Output of high side PMOS isolation switch
5	SENSE	Output voltage sense
6	LX	Output of NMOS switch
7	LBF	Low battery flag output: open drain (active low for low battery voltage) Active when EN is high or low
8	GND	Ground
9	FB	Voltage feedback pin for output (threshold 1.23V)
10	LBT	Low battery flag threshold adjust input (threshold 1.21V)

ORDERING INFORMATION

DEVICE	DEVICE DESCRIPTION	TEMPERATURE RANGE	PART MARK
ZXLB1600X10TA	Boost converter for LCD bias in MSOP10	0 °C to 70 °C	ZXLB1600
ZXLB1600X10TC	Boost converter for LCD bias in MSOP10	0 °C to 70 °C	ZXLB1600

TA reels 1k,
TC reels 4k devices.



ISSUE 3 - SEPTEMBER 2003

LAST TIME BUY

Closest Alternative Part AP5727WUG-7

ZXLB1600

BLOCK DIAGRAM

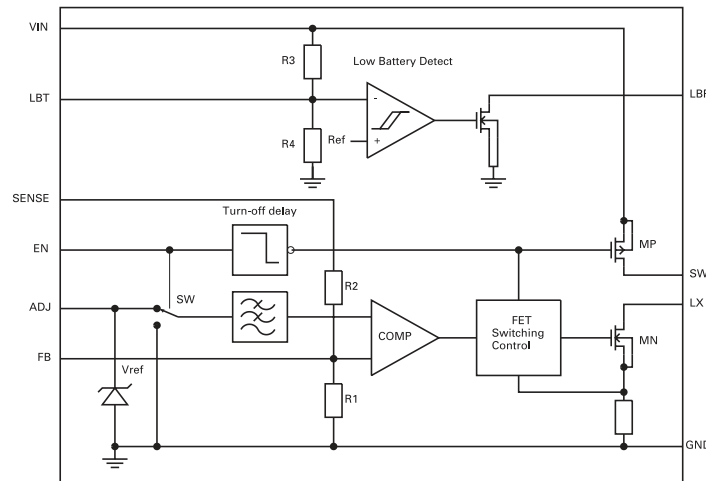

Device description

The device is a flyback boost converter, working in discontinuous mode.

With reference to the chip block diagram and typical application circuit, the operation of the device is as follows:

Control loop

When 'EN' is high, the control circuits become active. The high side of the coil is connected to the input via a large PMOS isolating switch (MP) and the low side to ground via NDMOS transistor (MN). The current in the coil is allowed to build up to an internally defined level (nominally 200 to 300mA) before MN is turned off. The energy stored in the coil is then transferred to the output capacitor (C2) via diode (D1). The output voltage is sensed at pin 'SENSE' by internal resistors R1 and R2 (which may be shunted externally at pin 'FB') and compared to a reference voltage (1.23V nominal). A comparator senses when the output voltage is above that set by the reference and its output is used to control the 'off' time of the output switch. The control loop is self-oscillating, producing pulses of 10µs maximum duration (switch 'on'), at a frequency that varies in proportion to the output load current. The minimum 'off' time of the output switch is fixed at 1.25µs nominal, to allow time for the coil's energy to be dissipated before the switch is turned on again. This maintains stable and efficient operation.

Setting output voltage

With external voltage

The output voltage is equal to the voltage present on the 'ADJ' pin of the device multiplied by the internal resistor network factor $(R1+R2)/R1$. The ADJ pin is connected to the internal reference voltage of value $V_{ADJ(nom)}$ and by default will give a nominal output of 28V. However, if required, the ADJ pin may be overdriven with an external dc voltage V_{ADJ} , in order to adjust the output voltage to a value lower than the default value.

LAST TIME BUY

Closest Alternative Part AP5727WUG-7

ZXLB1600

Filtered PWM operation

The input of an internal low pass filter is switched to V_{REF} when the EN pin is high and switched to ground when the EN pin is low. The output of this filter drives the comparator within the control loop. A continuous high state on EN therefore provides a filtered voltage of value V_{ref} to the comparator and the control loop regulates the output to a nominal value of 28V. However, by varying the duty cycle (D) of the EN signal at a suitably high frequency ($f > 10\text{kHz}$), the control loop will see a voltage, that has an average value equal to the duty cycle multiplied by V_{REF} . This provides a means of adjusting the output voltage to a lower value. It also allows the device to be both turned on and adjusted with a single signal at the 'EN' pin. The output during this mode of operation will be a dc voltage equal to $D \times 28\text{V}$

Gated PWM operation

The internal circuitry of the ZXLB1600 is turned off when no signal is present on the 'EN' pin for more than $120\mu\text{s}$ (nominal). A low frequency signal applied to the EN pin will therefore gate the device 'on' and 'off' at the gating frequency and the duty cycle of this signal can be varied to provide a 'chopped' output voltage equal to $D \times 28\text{V}$. For best accuracy, the gating frequency should be made as low as possible (e.g. below 1kHz), such that the turn off delay of the chip is only a small proportion of the gating period.

Further details of setting output current are given in the application notes.

Low battery detection

A comparator driving an open drain NMOS output transistor performs the low battery flag function. The detection threshold (battery voltage falling) is set to 1.98V nominal with internal resistors R3 and R4, but this can be changed by shunting the internal potential divider with two external resistors at pin 'LBT'. Operation is such that the output transistor will be turned on when the battery voltage falls below the detection threshold.

$$V_{BLT} = 1.21 \times (R3+R4)/R4$$

A small amount (nominal 20mV) of hysteresis is provided to aid clean switching. The low battery detection circuit remains active when 'EN' is low.

LAST TIME BUY

Closest Alternative Part AP5727WUG-7

ZXLB1600

TYPICAL OPERATING CHARACTERISTICS

(For typical applications circuit at $V_{in} = 3V$ and $T_A = 25^\circ C$ unless otherwise stated)

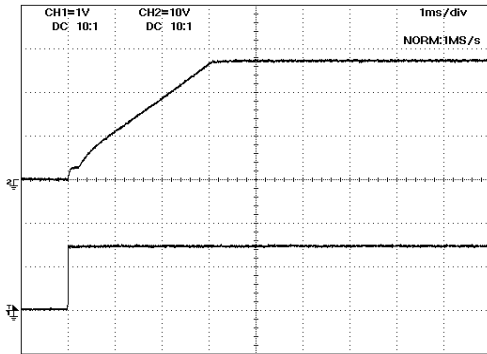

Plot 1 Start-up response at max output voltage 1mA load
Bottom: Enable input (1V/div), Top: Output voltage (10V/div)

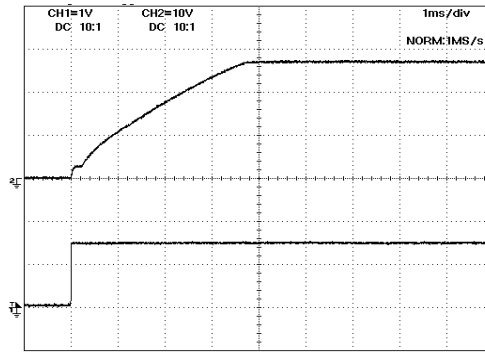

Plot 2 Start-up response at max output voltage 5mA load
Bottom: Enable input (1V/div), Top: Output voltage (10V/div)

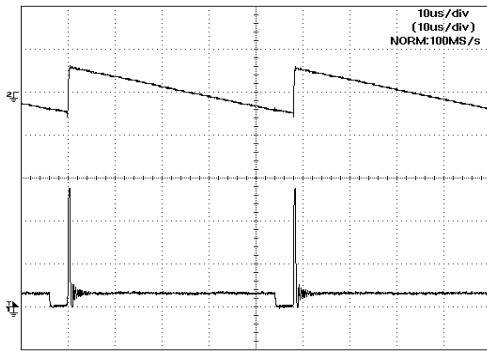

Plot 3 Operating waveforms at max output voltage 1mA load
Bottom: LX Output (10V/div), Top: Output voltage (50mV/div ac)

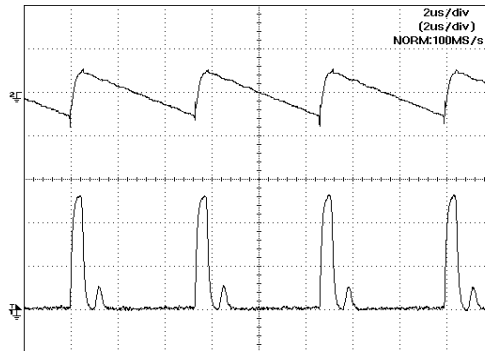

Plot 4 Operating waveforms at max output voltage 10mA load
Bottom: LX Output (10V/div), Top: Output voltage (50mV/div ac)

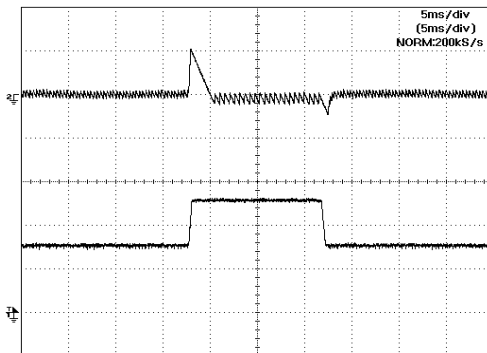

Plot 5 Line rejection at 1mA load
Bottom: Input voltage (1V/div), Top: Output voltage (0.2V/div ac)

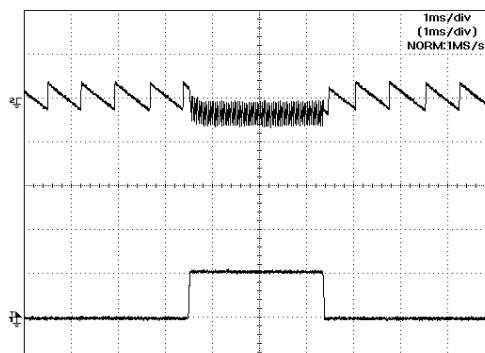

Plot 6 Load rejection
Bottom: Load current (1mA/div), Top: Output voltage (0.1V/div ac)

LAST TIME BUY

Closest Alternative Part AP5727WUG-7

ZXLB1600

TYPICAL OPERATING CHARACTERISTICS (Continued)

$V_{IN} = 3V$ and $T_A = 25^\circ C$

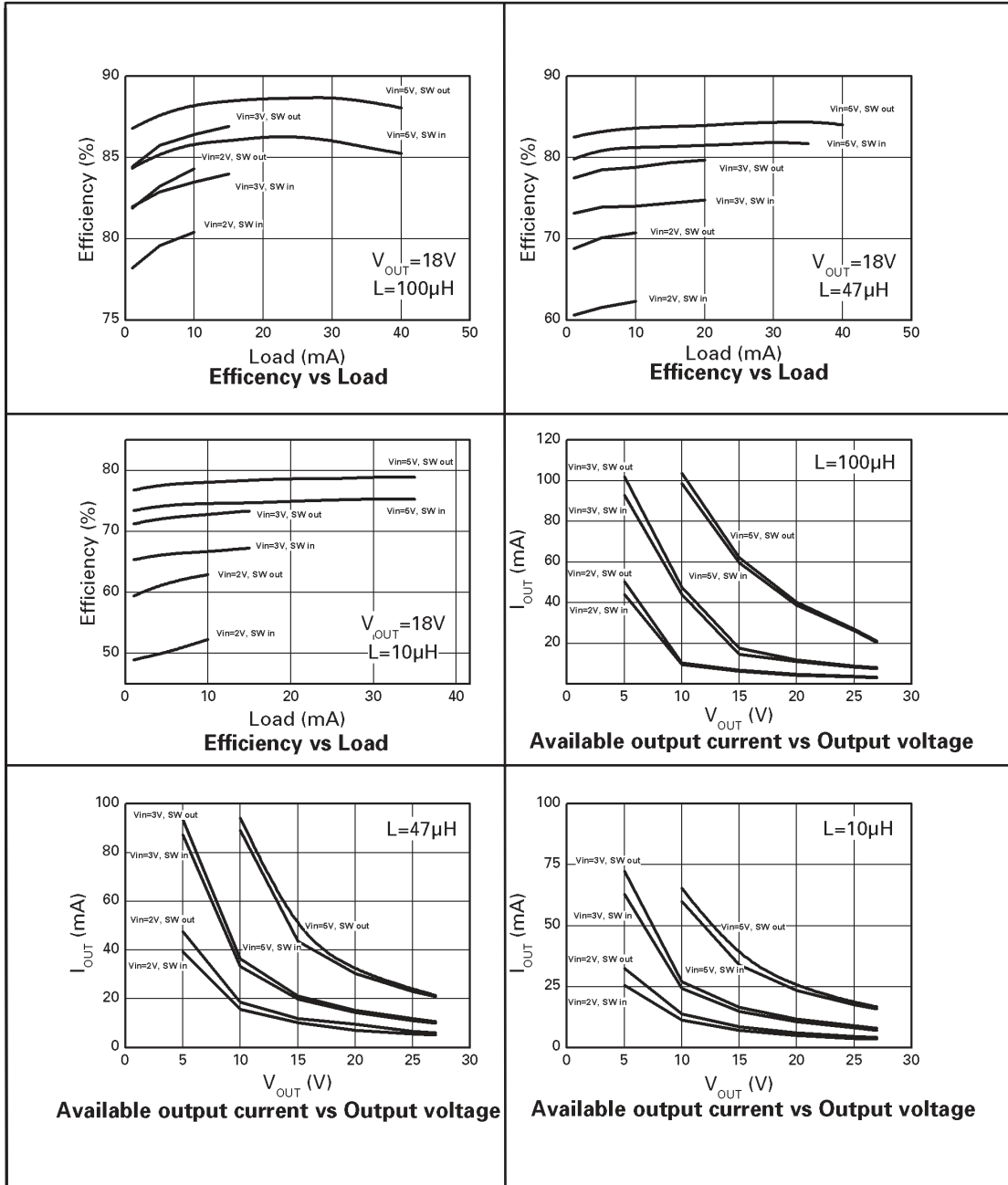

LAST TIME BUY

Closest Alternative Part AP5727WUG-7

ZXLB1600

TYPICAL OPERATING CHARACTERISTICS (Continued)

$V_{IN} = 3V$ and $T_A = 25^\circ C$

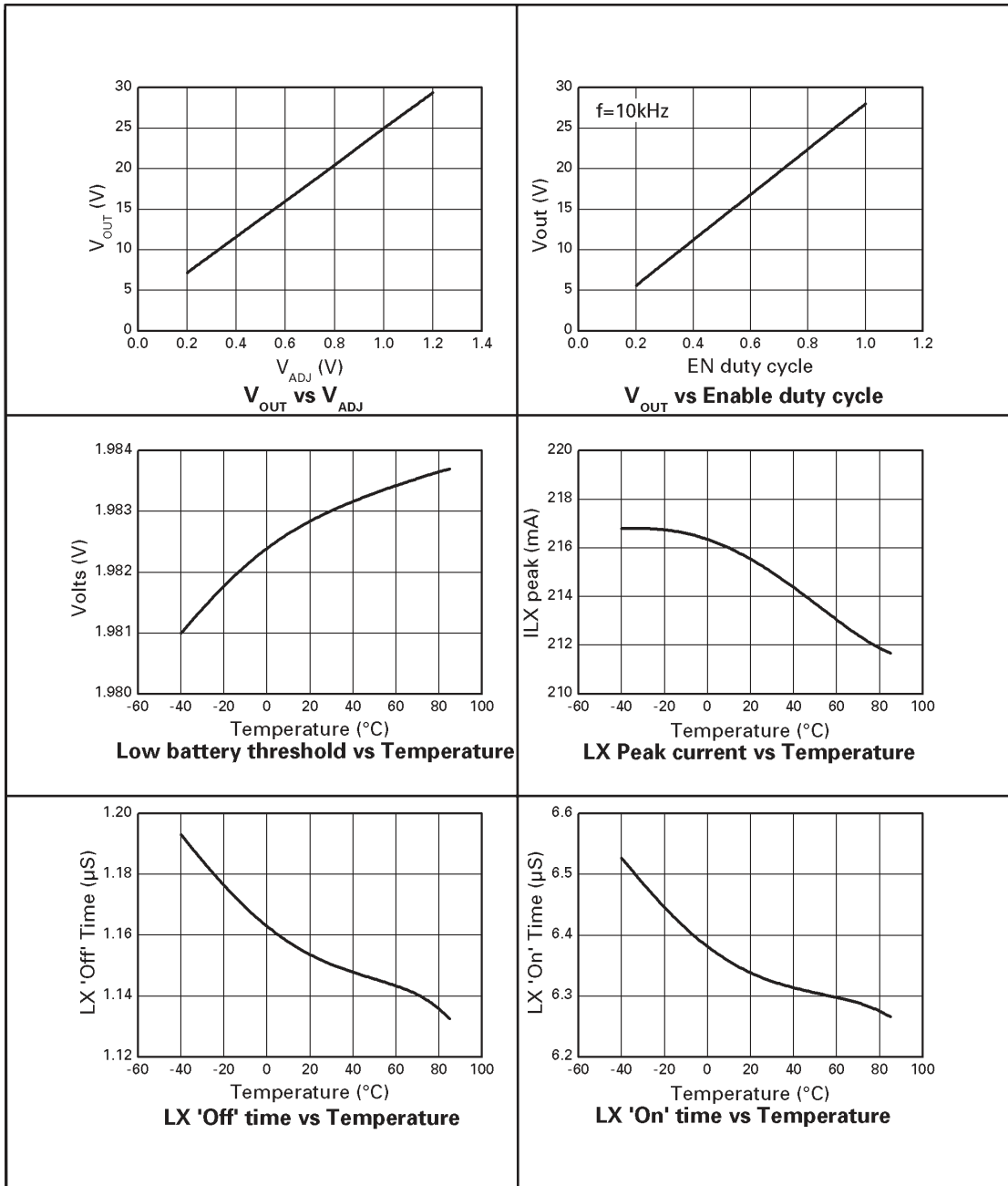

LAST TIME BUY

Closest Alternative Part AP5727WUG-7

ZXLB1600

TYPICAL OPERATING CHARACTERISTICS (Continued)

$V_{IN} = 3V$ and $T_A = 25^\circ C$

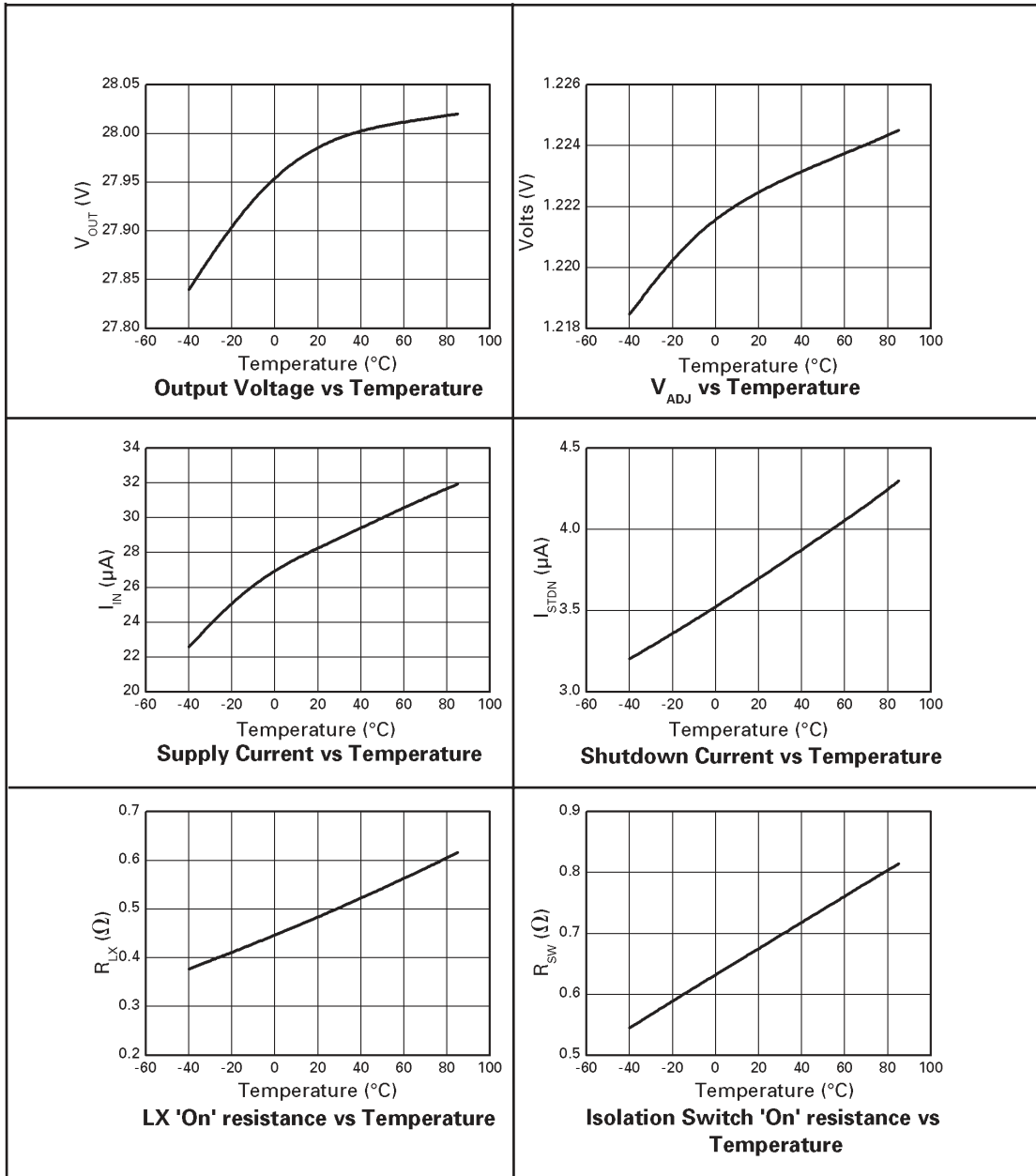

LAST TIME BUY

Closest Alternative Part AP5727WUG-7

ZXLB1600

APPLICATION NOTES

Adjusting output voltage

When connected as shown in the typical application circuit, the ZXLB1600 will produce a nominal output voltage of 28V. This can be adjusted by one of the three methods described below.

1) Output voltage adjustment by external resistors

The internal reference and resistor divider network R1 and R2 set a nominal output of 28V. However, this network is accessible at the FB pin and can be shunted by means of external resistors to set different nominal output voltages. The potential divider defines output voltage according to the relationship:

$$V_{OUT(dc)} = (R1+R2)/R1 \times 1.23V$$

When using external resistors, these should be chosen with lower values than the internal resistors to minimize errors caused by the $\pm 25\%$ absolute value variation of the internal resistors. The internal resistors have high values in order to minimize these errors.

The following table gives suggested E24/E96 resistor values for various output voltages.

Required output voltage	External resistor across R2	External resistor across R1
5V	280k Ω	91k Ω
12V	715k Ω	82k Ω
18V	1 M Ω	75k Ω
20V	1.15 M Ω	75k Ω
22V	1.15M Ω	68.1k Ω
25V	1.2 M Ω	62k Ω

2) Output adjustment by external voltage

The internal voltage reference (Pin ADJ) may be overdriven by an external control voltage to set the output voltage. The relationship between applied voltage (V_{ADJ}) and output voltage (V_{OUT}) is:

$$V_{OUT} = 22.86 \times V_{ADJ}$$

Note that the output can be set to any value between the input voltage and the maximum operating voltage

in this way. However, some non-linearity in the above expression may occur at values of V_{ADJ} below approximately 0.5V.

Also note that when driving the ADJ pin, the control voltage must have sufficiently low impedance to sink the bias current of the internal reference.(10 μ A max).

3) PWM output adjustment

A Pulse Width Modulated (PWM) signal can be applied to the EN pin in order to adjust the output voltage to a value below the value set in in 1) or 2). This method of adjustment permits the device to be turned on and the output voltage set by a single logic signal applied to the EN pin. No external resistors or capacitors are required and the amplitude of the control signal is not critical, providing it conforms to the limits defined in the electrical characteristics.

Two modes of adjustment are possible as described below:

Filtered 'DC' mode

If a PWM signal of 10kHz or higher is applied to the EN pin, the device will remain active when the EN pin is low. However, the input to the internal low pass filter will be switched alternately from V_{REF} to ground, with a duty cycle (D) corresponding to that of the PWM signal. This will present a filtered dc voltage equal to the duty cycle multiplied by V_{REF} to the control loop and will produce a dc output voltage lower than the maximum set value. This voltage is given by:

$$V_{OUT} = 28 \times D$$

A square wave signal applied to the EN pin, for example, will turn the device on and produce a nominal regulated output of 14V.

LAST TIME BUY

Closest Alternative Part AP5727WUG-7

ZXLB1600

Gated mode

The ZXLB1600 contains a timing circuit that switches the device on a few microseconds after the application of a rising edge to EN and turns it back off again nominally 120 μ s after the falling edge of EN. So, if a lower frequency of 1kHz or less is applied to the EN pin, the device will be gated on and off at a duty cycle (D) corresponding to that of the input signal. The average output voltage is then given by:

$$V_{OUT(avg)} \sim 28 \times D$$

Output voltage can be adjusted all the way down to the input voltage by means of PWM control, but for best results, the duty cycle range should be kept within the specified range of 0.4 to 1. Lower duty cycles may result in increased output ripple and non-linearity in the relationship between duty cycle and output voltage. If a greater control range, or reduced ripple is required, the nominal output can be adjusted by one of the other methods before the PWM signal is applied.

Negative output

The ZXLB1600 can be used to provide a negative output voltage (in addition to the normal positive output) as shown in the application circuit below. In this circuit, the external resistors R3 and R4 are used to set the output voltage to 22V as described in the previous section. These resistors and output capacitor

C2 have relatively low values in this circuit in order to give a short time constant. This improves the regulation of the negative voltage.

Capacitor selection

A low ESR ceramic capacitor grounded close to the GND pin of the package is recommended at the output of the device. Surface mount types offer the best performance due to their lower inductance. A minimum value of 1 μ F is advised, although higher values will lower switching frequency and improve efficiency especially at lower load currents. A higher value will also minimize ripple when using the device to provide an adjustable dc output voltage.

A good quality, low ESR capacitor should also be used for input decoupling, as the ESR of this capacitor is effectively in series with the source impedance and lowers overall efficiency. This capacitor has to supply the relatively high peak current to the coil and smooth the current ripple on the input supply. A minimum value of 3.3 μ F is acceptable if the input source is close to the device, but higher values are recommended at lower input voltages, when the source impedance is high. The input capacitor should be mounted as close as possible to the IC.

For maximum stability over temperature, capacitors with X7R dielectric are recommended, as these have a much smaller temperature coefficient than other types.

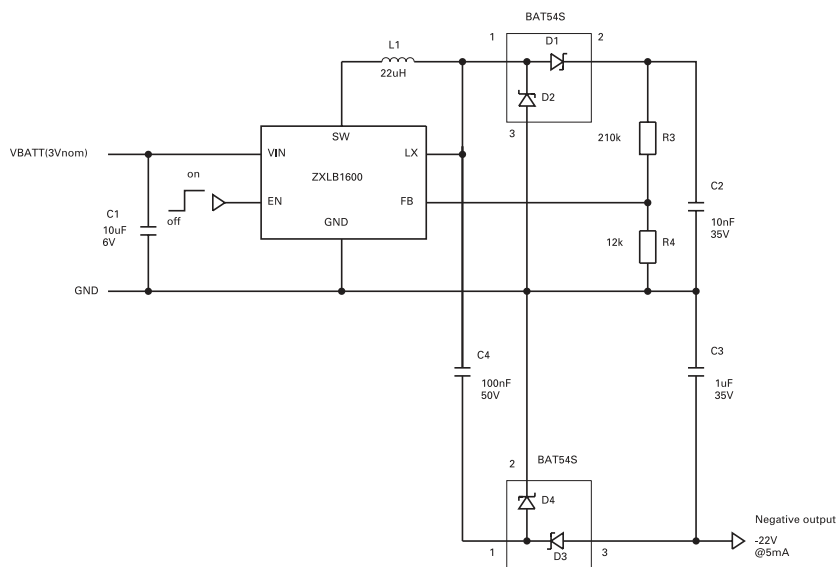

LAST TIME BUY

Closest Alternative Part AP5727WUG-7

ZXLB1600

Inductor selection

The choice of inductor will depend on available board space as well as required performance. Small value inductors have the advantage of smaller physical size and may offer lower series resistance and higher saturation current compared to larger values. A disadvantage of smaller inductors is that they result in higher frequency switching, which in turn causes reduced efficiency due to switch losses. Higher inductor values can provide better performance at lower supply voltages. However, if the inductance is too high, the output power will be limited by the internal oscillator, which will prevent the coil current from reaching its peak value. This condition will arise whenever the ramp time $t_{LX(peak)} \times L/V_{IN}$ exceeds the preset 10 μ s maximum 'on' time limit for the LX output.

The ZXLB1600 has been optimized for use with inductor values in the range 10 μ H to 100 μ H. The typical characteristics show how efficiency and available output current vary with input voltage and inductance. The inductor should be mounted as close to the device as possible with low resistance connections to the LX and SW pins.

Suitable coils for use with the ZXLB1600 are those in the LP02506 and DO1608 series, made by Coilcraft.

Diode selection

The rectifier diode (D1) should be a fast low capacitance switching type with low reverse leakage at the working voltage. It should also have a peak current rating above the peak coil current and a continuous current rating higher than the maximum output load current. Small schottky diodes such as the BAT54 are suitable for use with the ZXLB1600 and this diode will give good all round performance over the output voltage and current range. At lower output voltages, a larger schottky diode such as the ZHCS500 or MBR0540 will provide a smaller forward drop and higher efficiency. At higher output voltages, where forward drop is less important, a silicon switching diode such as the 1N4148 can be used, however this will give lower efficiency.

The BAT54S device specified in the application circuit contains a second diode (D2) as one half of a series connected pair. This second diode is used here to clamp possible negative excursions (due to coil ringing) from driving the drain of the output transistor below -0.5V. This prevents internal coupling effects, which might otherwise affect output regulation. The table below gives some typical characteristics for various diodes.

Diode	Forward voltage at 100mA (V)	Peak current (mA)	Continuous current (mA)	Reverse leakage (μ A)
BAT54	530	300	200	2
ZHCS500	300	1000	500	15
MBR0540	390	1000	500	1
1N4148	950	450	200	0.025

LAST TIME BUY

Closest Alternative Part AP5727WUG-7

ZXLB1600

Increased efficiency

If isolation of the coil from the supply is not needed, the high side of this can be connected directly to VIN to improve efficiency. This prevents power loss in the internal PMOS switch and typical efficiency gains of 5% can be achieved. (See efficiency vs. load curves). Some applications may require the coil to be fed from a separate supply with a different voltage to VIN. In this case, the SW pin should be left floating.

Layout considerations

PCB tracks should be kept as short as possible to minimize ground bounce and the ground pin of the device should be soldered directly to the ground plane. It is particularly important to mount the coil and the input/output capacitors close to the device to minimize parasitic resistance and inductance, which will degrade efficiency and increase output ripple. The FB and LBT pins are high impedance inputs, so PCB track lengths to these should also be kept as short as possible to reduce noise pickup. Output ripple is typically only 50mV p-p, but a small feed-forward capacitor (~100pF) connected from the FB pin to the output may help to reduce this further. Capacitance from the FB pin to ground should be avoided, but a capacitor can be connected from the LBT pin to ground to reduce noise pickup into the low battery comparator if required.

Low battery detection circuit

The device contains an independent Low Battery Detection Circuit that remains powered when the device is shutdown. The detection threshold is set internally to a default value of 1.98V, but can be adjusted by means of external resistors as described below.

Low battery threshold adjustment, LBT

The internal potential divider network R3/R4 sets the detection threshold. This is accessible at the LBT pin and can be shunted by means of external resistors to set different nominal threshold voltages. The potential divider defines threshold voltage according to the relationship:

$$V_{LBT} = (R3+R4)/R4 \times 1.21V$$

When using external resistors, these should be chosen with lower values than the internal resistors to minimize errors caused by the ±25% absolute value variation of the internal resistors. The internal resistors have high values in order to minimize these errors. It is suggested to use values less than half those shown for R3, R4 at the bottom of page 3.

Low battery flag output, LBF

This is an open drain output that switches low when the battery voltage falls below the detection threshold. An external pull-up resistor can be connected to this pin to allow it to interface to any voltage up to a maximum of 29V. Current in the pull-up resistor should be limited to a value below IBLOL.

LAST TIME BUY

Closest Alternative Part AP5727WUG-7

ZXLB1600

Notes:

LAST TIME BUY

Closest Alternative Part AP5727WUG-7

ZXLB1600

PACKAGE OUTLINE

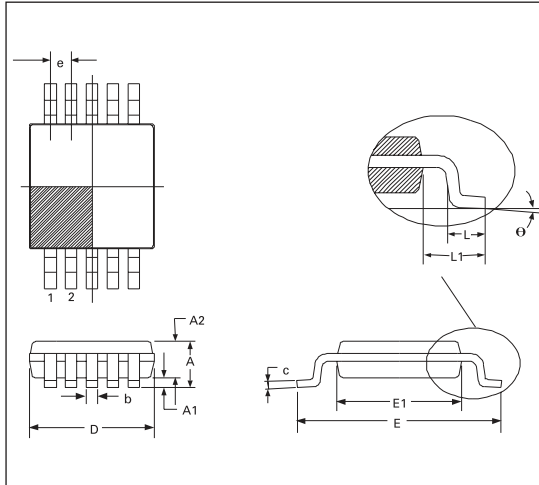

PACKAGE DIMENSIONS

DIM	MILLIMETER		INCHES	
	MIN.	MAX.	MIN.	MAX.
A	—	1.10	—	0.43
A1	—	0.15	—	0.006
A2	0.75	0.95	0.0295	0.037
D	3.00 BSC		0.118 BSC	
E	4.90 BSC		0.1929 BSC	
E1	3.00 BSC		0.118 BSC	
b	0.17	0.27	0.0066	0.0106
c	0.08	0.23	0.003	0.009
e	0.50 BSC		0.0196 BSC	
θ	0°	15°	0°	15°
L	0.40	0.80	0.015	0.031
L1	0.95 BSC		0.037 BSC	

Controlling dimensions are in millimeters. Approximate conversions are given in inches

© Zetex plc 2003

Europe

Zetex plc
Fields New Road
Chadderton
Oldham, OL9 8NP
United Kingdom
Telephone: (44) 161 622 4444
Fax: (44) 161 622 4446
hq@zetex.com

Zetex GmbH
Streitfeldstraße 19
D-81673 München
Germany
Telefon: (49) 89 45 49 49 0
Fax: (49) 89 45 49 49 49
europe.sales@zetex.com

Americas

Zetex Inc
700 Veterans Memorial Hwy
Hauppauge, NY 11788
USA
Telephone: (1) 631 360 2222
Fax: (1) 631 360 8222
usa.sales@zetex.com

Asia Pacific

Zetex (Asia) Ltd
3701-04 Metroplaza Tower 1
Hing Fong Road
Kwai Fong
Hong Kong
Telephone: (852) 26100 611
Fax: (852) 24250 494
asia.sales@zetex.com

These offices are supported by agents and distributors in major countries world-wide.

This publication is issued to provide outline information only which (unless agreed by the Company in writing) may not be used, applied or reproduced for any purpose or form part of any order or contract or be regarded as a representation relating to the products or services concerned. The Company reserves the right to alter without notice the specification, design, price or conditions of supply of any product or service.

For the latest product information, log on to www.zetex.com



ISSUE 3 - SEPTEMBER 2003