



soberton inc.

# SP DYNAMIC SPEAKER UNIT

Acoustic Product Specification

Product Number: SP-1609-2



Release | Revision: B/2018

## CONTENTS

This document contains the technical specifications for the dynamic speaker unit.

**Page 1**  
Speaker Electroacoustic Characteristics

General Specifications

**Page 2**  
Reliability Tests

**Page 3**  
Measuring Method (Speaker Mode)

Standard Test Condition of Speakers

**Page 4**  
Frequency Response Curve

**Page 5**  
Dimensions

**Page 6**  
Packing

## Dynamic Speaker Electroacoustic Characteristics

### Sound Pressure Level

92±3dB SPL@0.8, 1.0, 1.2 and 1.5KHz in average  
Measuring Condition: 0.7W (Sine wave) 10cm in 1cc closed box measured with baffler

### Frequency Response Curve

As shown in Figure 2

### Response Frequency

650±20%Hz @1V in free air  
950±20%Hz @ 1V in 1cc box

### Input Power (Nominal and Maximum)

Rated Noise Power 0.7W (in 1cc box)

Short Term Max Power: 1.0W (in 1cc box)

### Operation Test

Must be free audible noise (buzzes and rattles)

(300 ~ 5KHz frequency range, input level up to 2.37Vrms in 1cc box)

### Distortion

Less than 5% @2KHz, 0.1M, 0.7W in 1cc box

## General Specifications

### Operating Temperature Range

-20°C~+60°C

### Standard Test Conditions

Temperature 17°C ~ 25°C

Relative Humidity 45% ~ 80% (RH)

### AC Impedance

8±15%Ω (@ 2 KHz 1V) without baffler.

### Dimension

16.0 x 9.0 x H3.0mm  
WIRE 120mm (UL1571 / AWG 32#)

### IP Level

No rating



soberton inc.

## SP DYNAMIC SPEAKER UNIT

Acoustic Product Specification

Product Number: SP-1609-2



Release | Revision: B/2018

### CONTENTS

This document contains the technical specifications for the dynamic speaker unit.

#### Page 1

Speaker Electroacoustic Characteristics

General Specifications

#### Page 2

Reliability Tests

#### Page 3

Measuring Method (Speaker Mode)

Standard Test Condition of Speakers

#### Page 4

Frequency Response Curve

#### Page 5

Dimensions

#### Page 6

Packing

## Reliability Tests

The sound pressure as specified will neither deviate more than  $\pm 3\text{dB}$  from the initial value, nor have any significant damage after any of following testing.

### High Temperature Test

High Temperature  $+70\pm 2^\circ\text{C}$

Duration 96 hours

### Low Temperature Test

Low Temperature  $-30\pm 2^\circ\text{C}$

Duration 96 hours

### Heat Shock Test

High Temperature  $+70\pm 2^\circ\text{C}$

Low Temperature  $-30\pm 2^\circ\text{C}$

Changeover time < 30 seconds

Duration 1 hour

Cycle 100

### Humidity Test

Temperature  $+40\pm 2^\circ\text{C}$

Relative Humidity 90%~95%

Duration 96 hours

### Temperature Cycle Test

Temperature  $-30^\circ\text{C}$   $+70^\circ\text{C}$

Duration 45 minutes 45 minutes

Temperature gradient 1 ~  $3^\circ\text{C}/\text{min}$

Cycle 25

### Drop Test

Mounted with dummy set mass: 100 g

Height 1.5 m

Cycle 6 (1 each plain) Onto the concrete board

### Load Test

Speaker mode: White noise (EIA filter) for 96 hours@0.7W input power (in 1cc box)



soberton inc.

# SP DYNAMIC SPEAKER UNIT

Acoustic Product Specification

Product Number: SP-1609-2



Release | Revision: B/2018

## CONTENTS

This document contains the technical specifications for the dynamic speaker unit.

**Page 1**  
Speaker Electroacoustic Characteristics

General Specifications

**Page 2**  
Reliability Tests

**Page 3**  
Measuring Method (Speaker Mode)

Standard Test Condition of Speakers

**Page 4**  
Frequency Response Curve

**Page 5**  
Dimensions

**Page 6**  
Packing

## Measuring Method (Speaker Mode)

### Standard Test Condition

Temperature 15 ~ 35°C

Relative humidity 45% ~ 85%

Atmospheric pressure 860mbar to 1060mbar

### Standard Test Fixture

Input Power 0.7W

Zero Level -dB

Mode TSR

Potentiometer Range 50dB

Sweep Time 0.5sec

## Standard Test Condition of Speaker (Fig. 1)

### Standard test condition of speaker

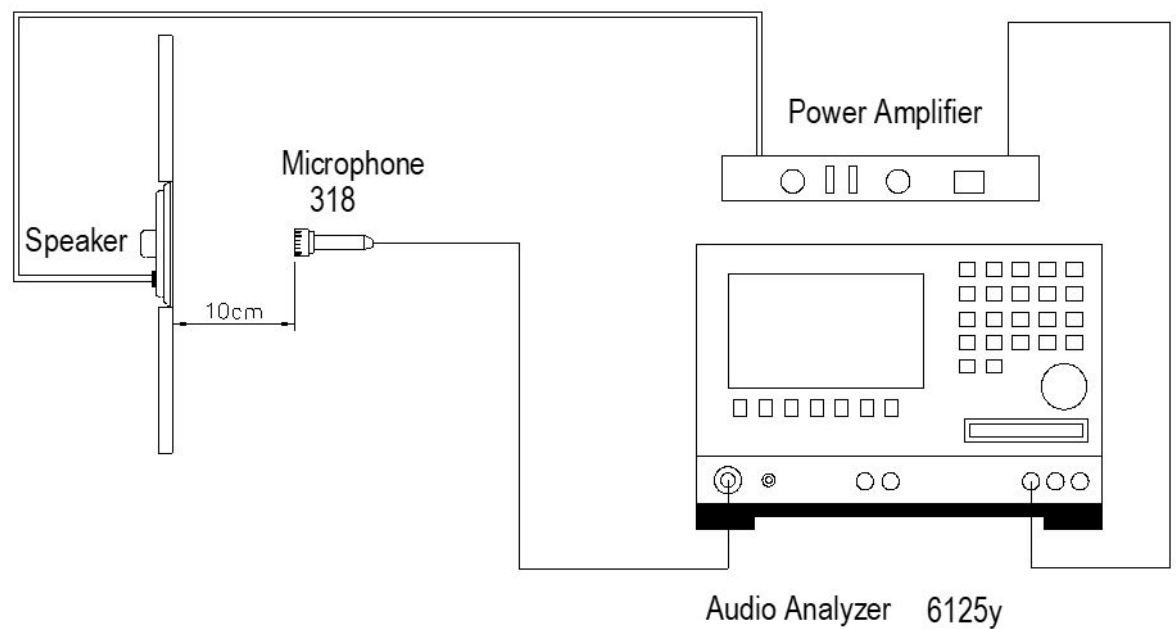



soberton inc.

## SP DYNAMIC SPEAKER UNIT

Acoustic Product Specification

Product Number: SP-1609-2



Release | Revision: B/2018

### CONTENTS

This document contains the technical specifications for the dynamic speaker unit.

#### Page 1

Speaker Electroacoustic Characteristics

General Specifications

#### Page 2

Reliability Tests

#### Page 3

Measuring Method (Speaker Mode)

Standard Test Condition of Speakers

#### Page 4

Frequency Response Curve

#### Page 5

Dimensions

#### Page 6

Packing

### Frequency Response Curve (Fig. 2)

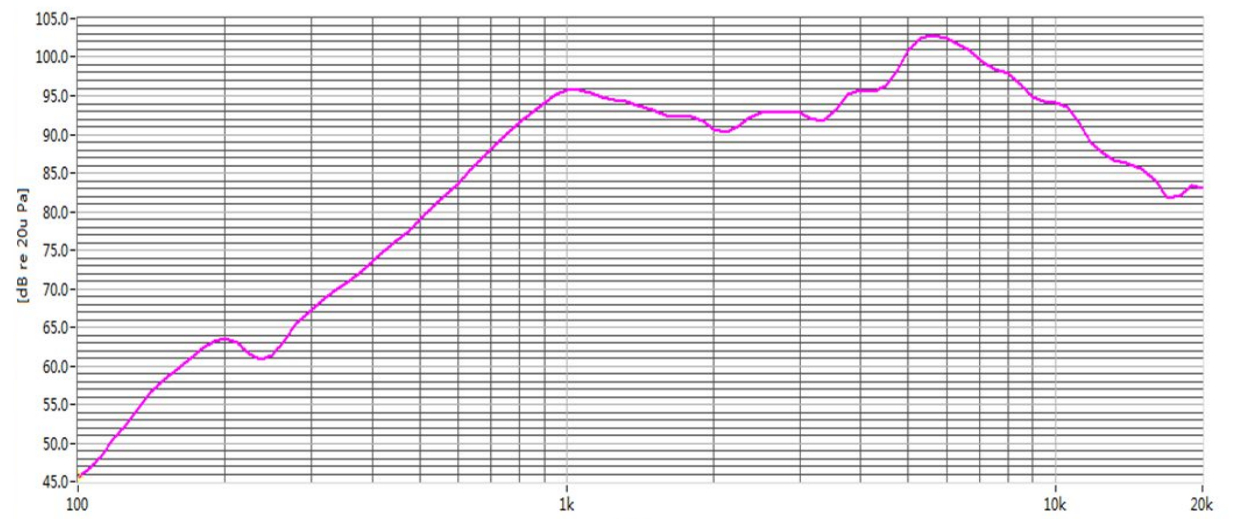



soberton inc.

# SP DYNAMIC SPEAKER UNIT

Acoustic Product Specification

Product Number: SP-1609-2



Release | Revision: B/2018

## CONTENTS

This document contains the technical specifications for the dynamic speaker unit.

### Page 1

Speaker Electroacoustic Characteristics

General Specifications

### Page 2

Reliability Tests

### Page 3

Measuring Method (Speaker Mode)

Standard Test Condition of Speakers

### Page 4

Frequency Response Curve

### Page 5

Dimensions

### Page 6

Packing

## Dimensions

Tolerance:  $\pm 0.5$  (unit: mm)

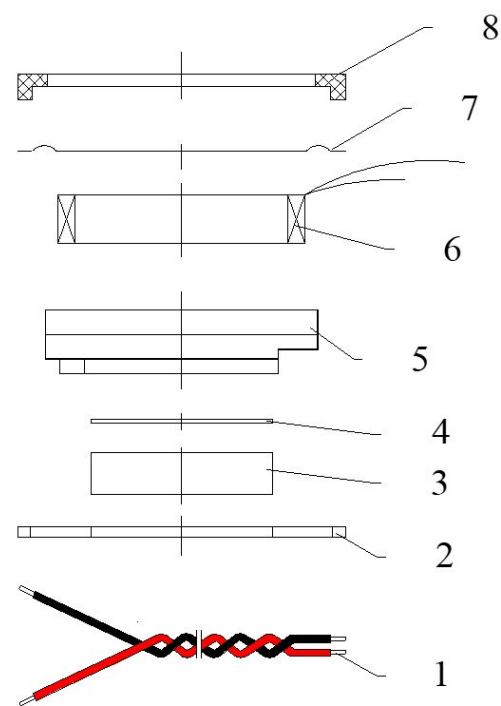
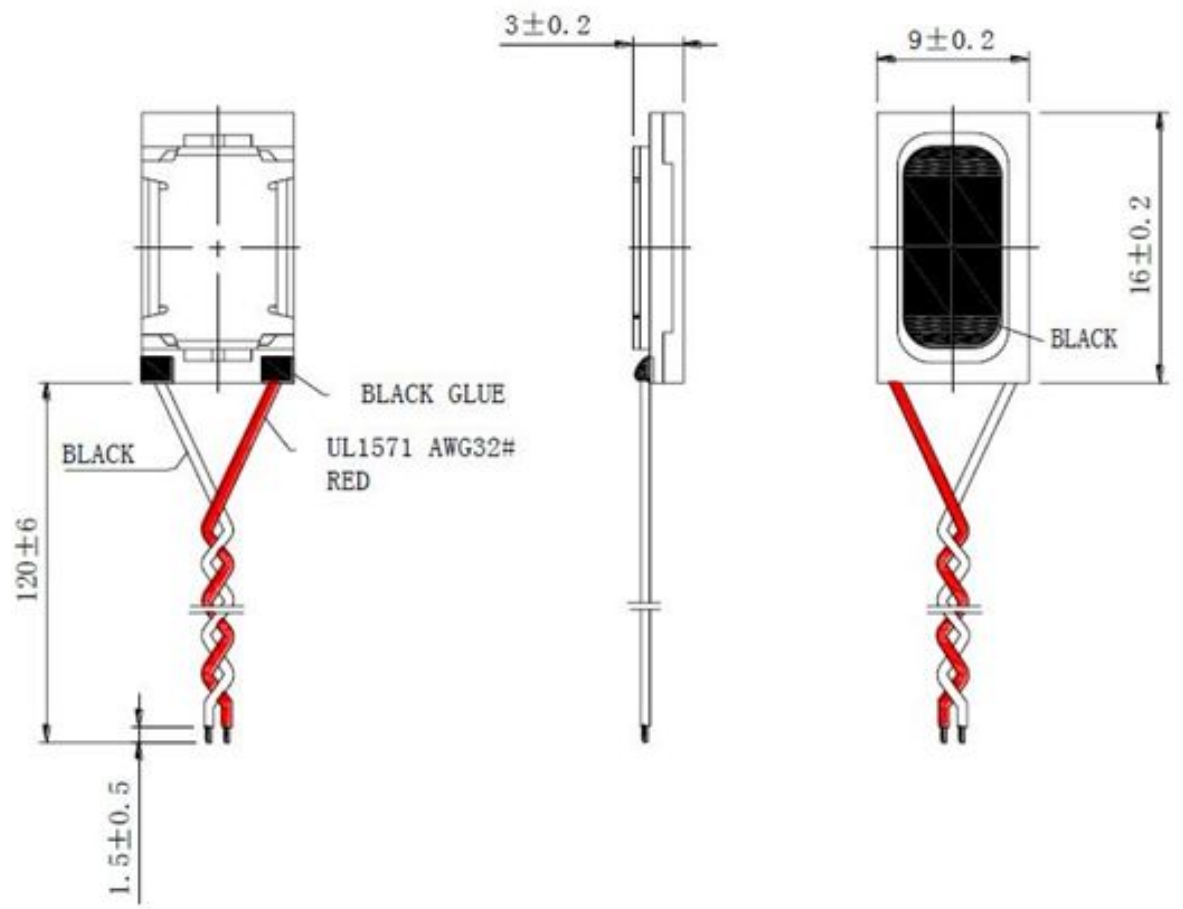

No.	Part Name	Material	Quantity
1	Wire (120mm)	UL1571 / AWG32#	2
2	U Yoke	SPCC	1
3	Magnet	Nd Fe B	1
4	Plate 3	SPCC	1
5	Frame	Black PPA	1
6	Voice Coil	Copper Wire	1
7	Diaphragm	PEEK	1
8	Cap	Black PPA	1



soberton inc.

# SP DYNAMIC SPEAKER UNIT

Acoustic Product Specification

Product Number: SP-1609-2



Release | Revision: B/2018

## CONTENTS

This document contains the technical specifications for the dynamic speaker unit.

### Page 1

Speaker Electroacoustic Characteristics

General Specifications

### Page 2

Reliability Tests

### Page 3

Measuring Method (Speaker Mode)

Standard Test Condition of Speakers

### Page 4

Frequency Response Curve

### Page 5

Dimensions

### Page 6

Packing

## Packing

100pcs

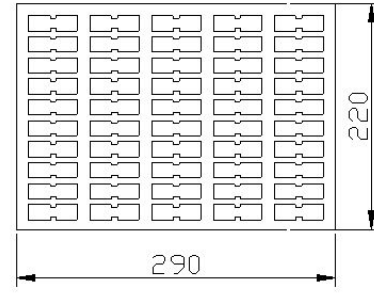

100x10 = 1000pcs

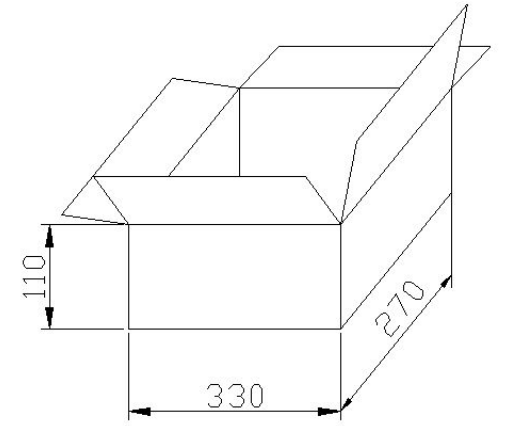
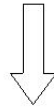
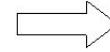
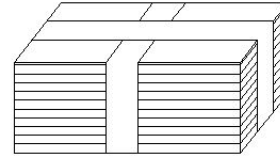

1000x5 = 5000pcs

