

B243000N2

SERIES
 B24= FORM A
 POLES
 2= 2 POLE & 3= 3 POLE
 CURVED BASE DIAMETER
 000= FLAT
 MATERIAL AND HOUSING COLOUR
 N= PA6 BLACK, G= PA6 GRAY

SCREW AND GASKET
 2= NBR FLAT GASKET & SCREWS
 6= NBR FLAT GASKET & NO SCREWS
 0= NO SCREWS OR GASKET

NOTES
 1. PLEASE SEE TABLE FOR CURRENTLY CONFIGURED PART NUMBERS.
 FOR SPECIFIC PART NUMBERS PLEASE CONTACT SALES OR CONSULT
 THE INTELLIGENT PART NUMBERS IN THE TABLE ATTACHED.
 2. FOR PACKAGING SEE PACKAGING SPEC PK-121012-B24
 3. PRODUCT SPEC: SEE PS-121201-001

LAST INSPECTION NUMBER 4

PART NO	MPM NO	DESCRIPTION	TERMINAL BEND ANGLE
1210120068	B243000N0	TYPE A 3P BLACK, NO GASKET, NO SCREW	45
1210120166	B242000N6	TYPE A 2P BLACK, NBR FLAT GASKET & NO FIXING SCREWS	45
1210120167	B243000G6	TYPE A 3P GRAY, NBR FLAT GASKET & NO FIXING SCREWS	45
1210120069	B243000N2	TYPE A 3P BLACK, NBR FLAT GASKET & SCREWS	45
1210120067	B243000G2	TYPE A 3P GRAY, NBR FLAT GASKET & SCREWS	45
1210120066	B242000N2	TYPE A 2P BLACK, NBR FLAT GASKET & SCREWS	45

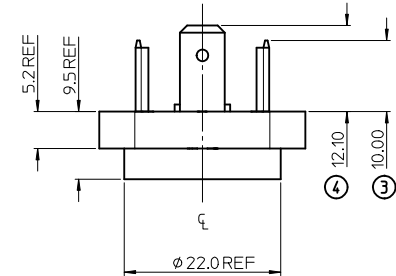
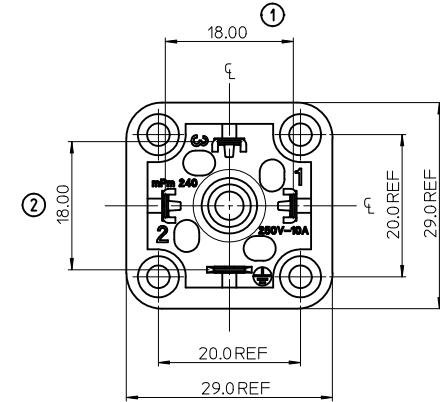
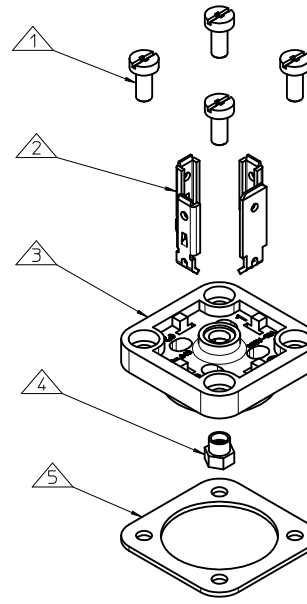

ITEM	DESCRIPTION
1	SCREWS
2	TERMINALS
3	HOUSING
4	SCREW INSERT
5	GASKET

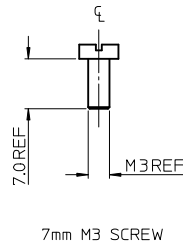
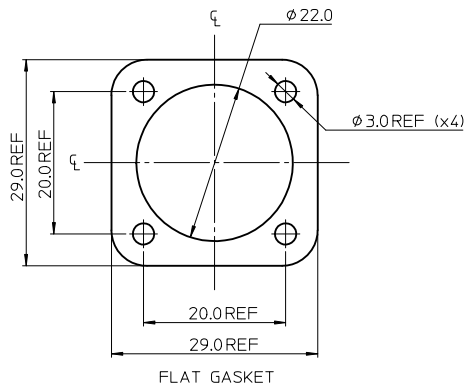

ORIGINAL RELEASE EC NO: WEU2011-0648 DRAWN BY: DRWINGSHEA 2011/06/23 CHKD:DMAHER 2011/06/23 APPR:EFOLAN 2011/07/06	DESCRIPTION REV A	QUALITY SYMBOLS ▽=0 ▽=0	GENERAL TOLERANCES (UNLESS SPECIFIED) <table border="1"> <thead> <tr> <th></th> <th>mm</th> <th>INCH</th> </tr> </thead> <tbody> <tr> <td>4 PLACES</td> <td>±---</td> <td>±---</td> </tr> <tr> <td>3 PLACES</td> <td>±---</td> <td>±---</td> </tr> <tr> <td>2 PLACES</td> <td>±0.1</td> <td>±---</td> </tr> <tr> <td>1 PLACE</td> <td>±0.2</td> <td>±---</td> </tr> <tr> <td colspan="3">ANGULAR ±---°</td> </tr> </tbody> </table>		mm	INCH	4 PLACES	±---	±---	3 PLACES	±---	±---	2 PLACES	±0.1	±---	1 PLACE	±0.2	±---	ANGULAR ±---°			DIMENSION STYLE MM ONLY	SCALE 2:1	DESIGN UNITS METRIC	THIRD ANGLE PROJECTION
			mm	INCH																					
		4 PLACES	±---	±---																					
		3 PLACES	±---	±---																					
2 PLACES	±0.1	±---																							
1 PLACE	±0.2	±---																							
ANGULAR ±---°																									
DRAWN BY: OSHEA 2011/06/23 CHECKED BY: DMAHER 2011/06/23 APPROVED BY: EFOLAN 2011/07/06		TITLE B24 SERIES BASE		MATERIAL NO. SEE TABLE																					
DRAFT WHERE APPLICABLE MUST REMAIN WITHIN DIMENSIONS		DIMENSION STYLE MM ONLY		MOLEX INCORPORATED																					
SIZE A 2		THIS DRAWING CONTAINS INFORMATION THAT IS PROPRIETARY TO MOLEX INCORPORATED AND SHOULD NOT BE USED WITHOUT WRITTEN PERMISSION		DOCUMENT NO. SD-121012-006		SHEET NO. 1 OF 1																			