

**BOURNS®**

**Features**

- Bushing mount
- Optional center tap and rear shaft extension
- Optional AR lug feature
- Gangable with common or concentric shafts

- High torque available
- Optional 0.1 % linearity
- Non-standard features and specifications available

**3540/3541 - Precision Potentiometer**

**Electrical Characteristics<sup>1</sup> 3540 Wirewound Element 3541 Hybritron® Element**

Standard Resistance Range	100 to 100 K ohms	1 K to 100 K ohms
Total Resistance Tolerance	±5 %	±10 %
Independent Linearity	±0.25 %	±0.25 %
Effective Electrical Angle	3600° +10°, -0°	3600° +10°, -0°
Absolute Minimum Resistance/	1 ohm or 0.1 % maximum	Minimum voltage
Minimum Voltage	(whichever is greater)	0.2 % maximum
Noise	100 ohms ENR maximum	Output smoothness 0.1 % maximum

Dielectric Withstanding Voltage (MIL-STD-202, Method 301)		
Sea Level	1,000 VAC minimum	1,000 VAC minimum
Power Rating (Voltage Limited By Power Dissipation or 447 VAC, Whichever Is Less)		
+70 °C	2 watts	2 watts
+125 °C	0 watt	0 watt
Insulation Resistance (500 VDC)		
	1,000 megohms minimum	1,000 megohms minimum
Resolution	See recommended part nos.	Essentially infinite

**Environmental Characteristics<sup>1</sup>**

Operating Temperature Range	+1 °C to +125 °C	+1 °C to +125 °C
Storage Temperature Range	-55 °C to +125 °C	-55 °C to +125 °C
Temperature Coefficient Over		
Storage Temperature Range <sup>2</sup>	±50 ppm/°C maximum/unit	±100 ppm/°C maximum/unit
Vibration	15 G	15 G
Wiper Bounce	0.1 millisecond maximum	0.1 millisecond maximum
Shock	50 G	50 G
Wiper Bounce	0.1 millisecond maximum	0.1 millisecond maximum
Load Life	1,000 hours, 2 watts	1,000 hours, 2 watts
Total Resistance Shift	±2 %	±5 %
Rotational Life (No Load)	1,000,000 shaft revolutions <sup>2</sup>	5,000,000 shaft revolutions <sup>2</sup>
Total Resistance Shift	±5 % maximum	±5 % maximum
Moisture Resistance (MIL-STD-202, Method 103, Condition B)		
Total Resistance Shift	±2 % maximum	±5 % maximum
IP Rating	IP 40	IP 40

**Mechanical Characteristics<sup>1</sup>**

Stop Strength	53 N-cm (75 oz-in.) minimum
Mechanical Angle	3600° +10°, -0°
Torque (Starting & Running)	0.35 N-cm (0.5 oz-in.) max.
Mounting	170-200 N-cm (15-18 lb-in.) max.
Shaft Runout	0.08 mm (0.003 in.) T.I.R.
Lateral Runout	0.13 mm (0.005 in.) T.I.R.
Shaft End Play	0.25 mm (0.010 in.) T.I.R.
Shaft Radial Play	0.25 mm (0.010 in.) T.I.R.
Pilot Diameter Runout	0.08 mm (0.003 in.) T.I.R.
Backlash	1.0° maximum
Weight	Approximately 21 gm
Terminals	Gold-plated solder lugs
Soldering Condition	Recommended hand soldering using Sn95/Ag5 no clean solder, 0.025 " wire diameter. Maximum temperature 399 °C (750 °F) for 3 seconds. No wash process to be used with no clean flux.
Marking	Manufacturer's name and part number, resistance value and tolerance, linearity tolerance, wiring diagram, and date code
Ganging (Multiple Section Pots.)	2 cups maximum
Hardware	One lockwasher (H-37-2) and one mounting unit (H-38-2) is shipped with each potentiometer.

<sup>1</sup>At room ambient: +25 °C nominal and 50 % relative humidity nominal, except as noted.  
<sup>2</sup>Consult manufacturer for complete specification details.

**Recommended Part Numbers**

Part Number	Resistance	Resolution
3540S-1-201	200	.042
3540S-1-501	500	.031
3540S-1-102	1,000	.027
3540S-1-202	2,000	.021
3540S-1-502	5,000	.021
3540S-1-103	10,000	.019
3540S-1-203	20,000	.014
3540S-1-503	50,000	.011
3540S-1-104	100,000	.008

Part Number	Resistance
3541H-1-102	1,000
3541H-1-202	2,000
3541H-1-502	5,000
3541H-1-103	10,000
3541H-1-203	20,000
3541H-1-503	50,000
3541H-1-104	100,000

**3540S-1/3541H-1**

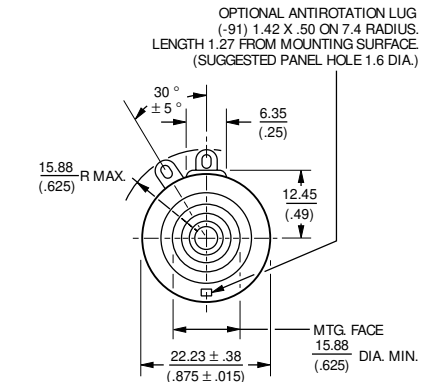
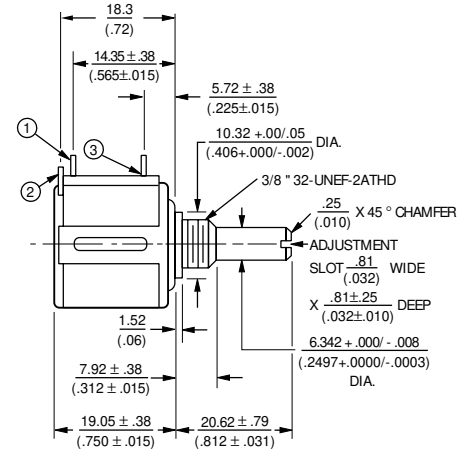

TOLERANCES: EXCEPT WHERE NOTED  
 DECIMALS: .XX ± .25 (.010), .XXX ± .13 (.005)  
 FRACTIONS: ±1/64  
 DIMENSIONS: MM (IN.)

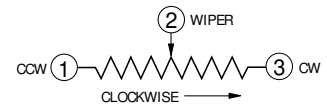

**BOLDFACE LISTINGS ARE IN STOCK AND READILY AVAILABLE THROUGH DISTRIBUTION.**  
 FOR SERVO MOUNT VERSION AND OTHER OPTIONS CONSULT FACTORY.