

THROUGH HOLE

SHEET #	MODULE HEIGHT	LATCH	ROTATION	PCB PATTERN
2	.125	PLASTIC	STANDARD(LEFT)	PATTERN 1
3	.125	PLASTIC	REVERSE(RIGHT)	PATTERN 3
4	.160	PLASTIC	STANDARD(LEFT)	PATTERN 1
5	.160	PLASTIC	STANDARD(LEFT)	PATTERN 2
6	.160	PLASTIC	REVERSE(RIGHT)	PATTERN 3
7	.160	METAL	STANDARD(LEFT)	PATTERN 1
8	.160	METAL	STANDARD(LEFT)	PATTERN 2
9	.160	METAL	REVERSE(RIGHT)	PATTERN 3
10	.190	PLASTIC	STANDARD(LEFT)	PATTERN 1
11	.190	PLASTIC	STANDARD(LEFT)	PATTERN 2
12	.190	PLASTIC	REVERSE(RIGHT)	PATTERN 3
13	.190	METAL	STANDARD(LEFT)	PATTERN 1
14	.190	METAL	STANDARD(LEFT)	PATTERN 2
15	.190	METAL	REVERSE(RIGHT)	PATTERN 3
16	.250	PLASTIC	STANDARD(LEFT)	PATTERN 1
17	.250	PLASTIC	STANDARD(LEFT)	PATTERN 2
18	.250	PLASTIC	REVERSE(RIGHT)	PATTERN 3
19	.250	METAL	STANDARD(LEFT)	PATTERN 1
20	.250	METAL	STANDARD(LEFT)	PATTERN 2
21	.250	METAL	REVERSE(RIGHT)	PATTERN 3
22	.290	PLASTIC	STANDARD(LEFT)	PATTERN 1
23	.290	PLASTIC	STANDARD(LEFT)	PATTERN 2
24	.290	PLASTIC	REVERSE(RIGHT)	PATTERN 3
25	.290	METAL	STANDARD(LEFT)	PATTERN 1
26	.290	METAL	STANDARD(LEFT)	PATTERN 2
27	.290	METAL	REVERSE(RIGHT)	PATTERN 3

THROUGH HOLE PATTERNS

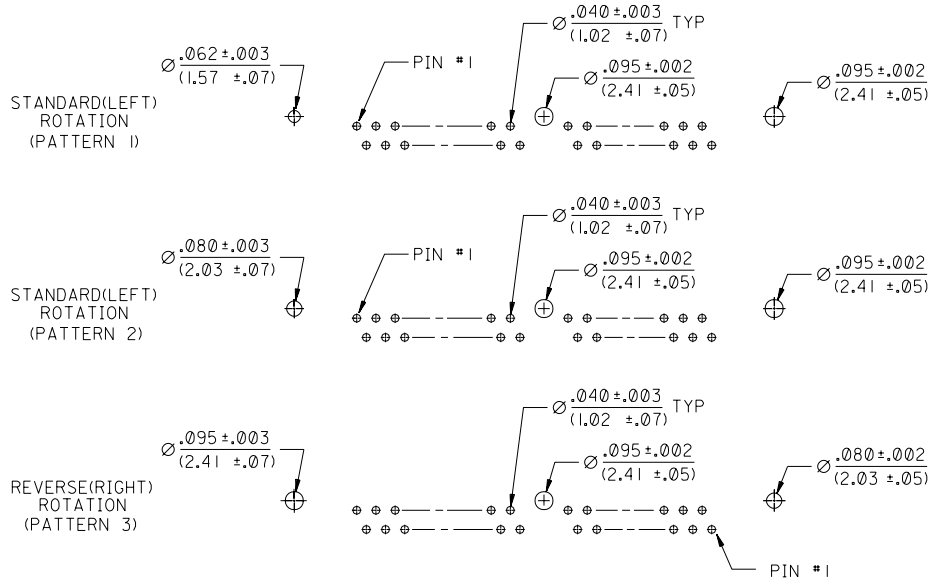

SURFACE MOUNT

SHEET #	MODULE HEIGHT	LATCH	ROTATION	PCB PATTERN
28	.160	METAL	STANDARD(LEFT)	PATTERN 4
29	.160	METAL	REVERSE(RIGHT)	PATTERN 5
30	.190	METAL	STANDARD(LEFT)	PATTERN 4
31	.190	METAL	REVERSE(RIGHT)	PATTERN 5
32	.250	METAL	STANDARD(LEFT)	PATTERN 4
33	.250	METAL	REVERSE(RIGHT)	PATTERN 5
34	.290	METAL	STANDARD(LEFT)	PATTERN 4
35	.290	METAL	REVERSE(RIGHT)	PATTERN 5

SURFACE MOUNT PATTERNS

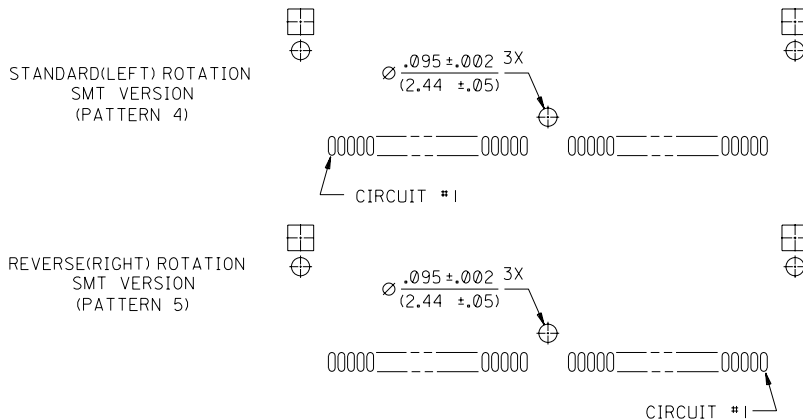

P.C. BOARD HOLE PATTERNS

35	D
34	D
33	D
32	D
31	D
30	D
29	D
28	D
27	D
26	D
25	D
24	D
23	D
22	D
21	D
20	D
19	D
18	D
17	D
16	D
15	D
14	D
13	D
12	D
11	D
10	D
9	D
8	D
7	D
6	D
5	D
4	D
3	D
2	D
1	D

DIMENSIONS SHOWN (METRIC) INCH		▽ = 0		= 0		REVISE ONLY ON CAD SYSTEM	
UNLESS OTHERWISE SPECIFIED TOLERANCES: ANGULAR ± 1/2°							
INCH		METRIC					
3 PLACE	± .01	---					
2 PLACE	± .014	± 0.25					
1 PLACE	---	± 0.36					
DRAFT WHERE APPLICABLE MUST REMAIN WITHIN DIMENSIONS							
DRWG. BY	AMD	CHK'D. BY		FILE NAME	SD78968001	SHEET NO.	1 OF 35
APP'D. BY		SCALE	2 : 1	DATE	11/11/93	U.S.A.	
SEE CHART				SDA-78968-*****			
THIS DRAWING CONTAINS INFORMATION THAT IS PROPRIETARY TO MOLEX INC. AND SHOULD NOT BE USED WITHOUT WRITTEN PERMISSION.							

78968

