

MATERIALS AND FINISHES

BODY BRASS  
PLATED GOLD

CENTER CONTACT BRASS  
PLATED GOLD

INSULATOR TEFLON

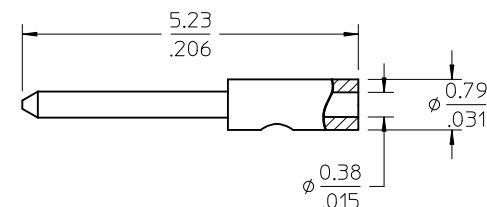
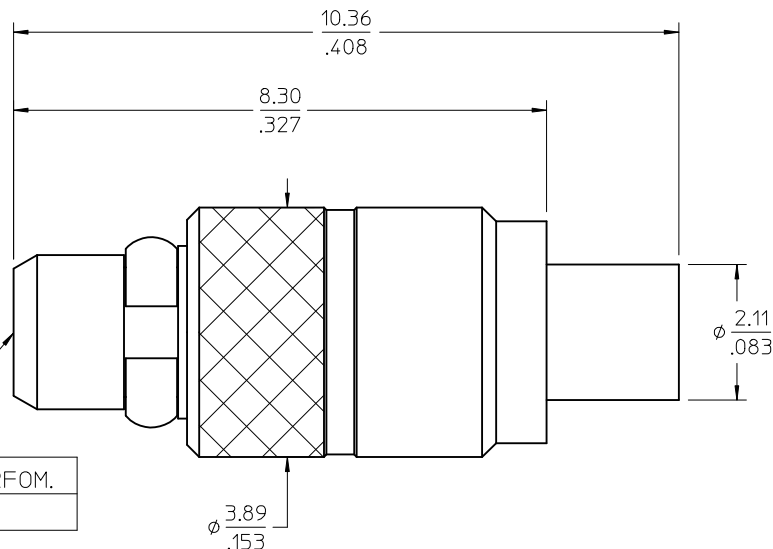
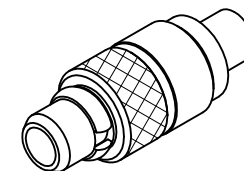
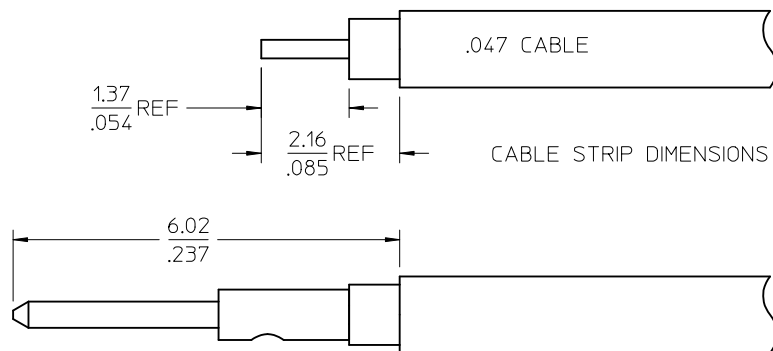

PS-89675-1920	ELECTRO/MECH PERFORM.
SPECIFICATION	DESCRIPTION

73415-2112	73415-2111, ONE PER BAG	FLASH	30u"
73415-2111	PER COMMERIAL REQUIREMENTS, BULK	FLASH	30u"
73415-2110	PER MILITARY REQUIREMENTS, BULK	30u"	50u"
PART NO.	PLATING AND PACKAGING	BODY, CAP, RING	CONTACT
		GOLD THICKNESS	GOLD THICKNESS

CHG: ADD GOLD PLATING INFO EC NO: URF2011-0341 DRWN: WIENER 2010/12/16 CHKD: SSS 2010/12/16 APPR: WIENER 2010/12/17 REV: A2	QUALITY SYMBOLS ▼=0 ▽=0	GENERAL TOLERANCES (UNLESS SPECIFIED)	DIMENSION STYLE MM/IN	SCALE	DESIGN UNITS METRIC	THIRD ANGLE PROJECTION	
		4 PLACES ± --- ± --- 3 PLACES ± --- ± --- 2 PLACES ± --- ± --- 1 PLACE ± --- ± ---	DRAWN BY DATE TEF 2002/01/21	CHECKED BY DATE SSS 2002/01/21	TITLE MMCX PLUG FOR SR047 CABLE, 50 OHMS MMCX-PC EWR-3339	MOLEX INCORPORATED	SHEET NO. 1 OF 1
		ANGULAR ± 2 °	APPROVED BY DATE GMH 2002/01/21	MATERIAL NO. SEE TABLE	DOCUMENT NO. SD-73415-211	THIS DRAWING CONTAINS INFORMATION THAT IS PROPRIETARY TO MOLEX INCORPORATED AND SHOULD NOT BE USED WITHOUT WRITTEN PERMISSION	
		DRAFT WHERE APPLICABLE MUST REMAIN WITHIN DIMENSIONS	SIZE C				